

## **Specification CT841 - 2016**

# **Standard for Petroleum and Chemical Industry Definite Purpose, Severe-Duty, Totally Enclosed Air Over (TEAO) Permanent Magnet Synchronous Cooling Tower and Air Cooled Heat Exchanger Direct Drive Motors Up to and Including 370 kW (500 hp)**

## 1. Overview

### 1.1 Scope

This standard applies to Totally Enclosed Air Over (TEAO), vertical, shaft up or down variable speed, definite purpose, permanent magnet polyphase synchronous, motors up to and including 370KW (500HP), and 600V nominal, for petroleum, chemical, and other severe duty, direct drive cooling tower and air cooled heat exchanger applications. Excluded from the scope of this standard are motors with sleeve bearings and additional specific features required for explosion-proof motors.

### 1.2 Purpose

The purpose of this standard is to define a specification that deals with mechanical and electrical performance, electrical insulation systems, corrosion protection, and electrical and mechanical testing for severe-duty TEAO permanent magnet polyphase synchronous motors, up to and including 370 kW (500 hp), for petroleum and chemical industry cooling tower and air cooled heat exchanger applications. Many of the specified materials and components in this standard stem from experience with severely corrosive atmospheres and the necessity for safe, quiet, reliable, definite purpose, adjustable speed motors.

## 2. Normative references

This standard shall be used in conjunction with the following standards. When the following standards are superseded by an approved revision, the new revision shall apply.

ABMA 9-2015, Load Ratings and Fatigue Life for Ball Bearings.

ABMA 11-2014, Load Ratings and Fatigue Life for Roller Bearings.

ABMA 20-2013, Radial Bearings of Ball, Cylindrical Roller and Spherical Roller Types—Metric Design.

ASME B 1.1-2003, Unified Inch Screw Threads (UN and UNR Thread Form) including Appendix C.

ASTM B 117-2011, Standard Practice for Operating Salt Spray (Fog) Apparatus.

IEEE Std 117-2015, IEEE Standard Test Procedure for Evaluation of Systems of Insulating Materials for Random-Wound AC Electric Machinery.

NEMA MG 1-2011 Motors and Generators.

NFPA 70-2011, National Electrical Code (NEC).

### 3. Service conditions

#### 3.1 Usual service conditions

Unless otherwise specified, motors conforming to this standard shall be suitable for operation within their rating under the following service conditions:

- a) Exposure to an ambient temperature in the range of -25 °C to +40 °C
- b) Exposure to a maximum altitude of 1000 m above sea level
- c) Outdoor severe-duty applications, such as humid, chemical (corrosive), or salty atmospheres
- d) Operation on an adjustable speed drive (ASD) specifically designed to operate permanent magnet polyphase synchronous motor.
- e) Axial fan thrust loading within motor manufacturers standard capabilities
- f) 1.0 service factor

#### 3.2 Unusual service conditions

Unusual service conditions should be brought to the attention of those responsible for the design, manufacture, application, and operation of the motor. Such unusual conditions include the following:

- a) Exposure to
  - 1) Flammable or explosive gases.
  - 2) Combustible, explosive, abrasive, or conductive dust.
  - 3) Nuclear radiation
  - 4) Abnormal shock, vibrations, or mechanical loading from external sources
  - 5) Abnormal axial or side thrust imposed on the motor shaft
  - 6) Altitude or ambient temperature outside the range covered in 3.1
- b) Application in Class I Division 2 and Class 1 Zone 2 areas and IEC Ex nA on ASD power in accordance with the applicable codes and standards.
- c) Conditions under which the variation from rated voltage or frequency, or both, differ from the limits given in item a) of 5.3.1
- d) Conditions under which the ac supply voltage is unbalanced by more than 1% (see Section 14.36 of NEMA MG 1-2011)

### 4. Ratings

#### 4.1 Basis of rating

Motors shall be rated on a continuous-duty basis at 1.0 service factor. The output rating shall be expressed in power available at the shaft at the specified speed, frequency, and voltage.

#### 4.2 Frame assignments

Motor frame size assignments shall be in accordance with the manufacturer's standard.

#### 4.3 Voltage and frequency ratings

Input voltages and frequencies into the ASD are 460V and 575V for 60Hz, and 380V, 400V, and 415, and 600V at 50Hz.

Note: Other voltage and frequency input combinations may be available, please consult the manufacturer.

#### 4.4 Maximum speed rating

Motor maximum speed (as listed on the data sheet, Figure B.1) shall coincide with the maximum fan operating speed.

#### 4.5 Enclosures

Enclosures shall be TEAO and shall have a degree of protection of IP 66. If replaceable external shaft seals are used to achieve this degree of protection, they shall be the noncontact type with a minimum expected seal life of 5 years under usual service conditions. For shaft up applications, a shaft slinger shall be used external to and in addition to the noncontact shaft seal. Degrees of protection are defined in NEMA MG 1-2011, Part 5.3 Drain fitting holes are permitted to be plugged during the enclosure IP 66 ingress test.

### 5. Electrical performance

#### 5.1 Motor performance characteristics

Motor performance capability shall be in accordance with NEMA MG 1-2011, part 31.4

#### 5.2 Power supply variations

##### 5.2.1 Adjustable speed drive (ASD) Supply

The motors supplied under this standard are to be applied on a nonsinusoidal source and are used on an adjustable speed application. The manufacturer should be consulted to determine whether the motor will operate successfully over the required speed range. Refer to NEMA MG 1-2011, Part 31.3.3. Proper selection of the motor and drive is required to avoid the following conditions:

- a) Motor current (rms) exceeding the continuous nameplate rating due to excessive voltage harmonics or improper volt/hertz levels
- b) Excessive winding temperature due to insufficient cooling, excessive torque levels, or improper volt/hertz levels; and increased losses due to harmonics

- c) Insufficient motor accelerating torque at reduced speeds due to insufficient volt/hertz levels or limitations in the drive's momentary current capacity
- d) Increased noise levels due excitation of mechanical resonances, and/or magnetic noise caused by supply source harmonics
- e) Mechanical failure of the motor due to torque pulsations, operation at or near mechanical resonances, or excess speed
- f) Winding failures due to repetitive high-amplitude voltage spikes created by the carrier frequency of the drive fast switching transients and the motor feeder cable system
- g) Damage to the motor and drive due to improper application of power factor correction capacitors or harmonic filters
- h) Higher motor temperatures that may limit application in Division 2 hazardous areas
- i) Shaft-to-bearing voltages and/or currents resulting from common mode currents flowing through stray system capacitances to ground via the bearings. These currents are induced from the ASD's high rate of change ( $dv/dt$ ) of output voltage
- j) The ASD must be capable of operating a permanent magnet polyphase synchronous motor in a sensor less configuration.

### 5.3 Insulation system and temperature rise

#### 5.3.1 Insulation system

- a) The motor shall have a nonhygroscopic, chemical- and humidity-resistant insulation system. The thermal rating of the insulation system shall be a minimum of Class H as defined in Section 1.66 of NEMA MG 1-2011. Any lead wire with a temperature rating more than 5 °C less than the temperature rating of the insulation system in which it is connected shall be separated from the windings by a barrier or envelope of a material compatible with the insulation system. The temperature rating of the lead wire shall not be less than 180 °C.
- b) The completed, non-energized stator with leads, without end bells or rotor, shall be capable of passing the insulation system humidity resistance test in A.5.
- c) The thermal classification of the insulation system shall be determined using IEEE Std 117-2015 for random windings.
- d) The insulation system shall use vacuum-pressure-impregnated (VPI) random windings, capable of withstanding a voltage surge of 3.5 per unit at a rise time of 0.1  $\mu$ s to 0.2  $\mu$ s and of 5 per unit at a rise time of 1.2  $\mu$ s or longer. (One per unit equals 0.8165  $V_{LL}$ ).
- e) The stator end-windings shall be suitably supported to successfully withstand the electromagnetic and mechanical forces encountered per 3.1, 3.2, and 5.2.
- f) Phase insulation in addition to varnish shall be used between each phase group of random windings.

### 5.3.2 Temperature rise

When operated on application matched permanent magnet motor ASD power, the average temperature rise of any phase of the stator winding shall not exceed 80 °C as determined by the winding resistance method. Maximum exposed internal and external surface temperatures shall not exceed 200 °C under usual service conditions at 1.0 SF. Minimum air flow as specified by the manufacturer must be maintained at the motor frame and is the responsibility of the user.

## 6. Mechanical features

### 6.1 Bearings and lubrication

- a) Vertical motor ball bearing manufacturing tolerance limits shall be in accordance with Table 4 of ABMA 20-2011. Ball bearings shall have ABMA C/3 clearances.
- b) Bearings shall be greasable without disassembly and shall contain a reservoir equipped with outlet plugs for elimination of purged grease. Inner bearing caps shall be provided so that entry of grease into the motor interior is minimized. Bearings and grease reservoirs shall be protected from entry of contaminants per 4.5.
- c) For vertical mounted motors with axial thrust-loading, angular contact ball (single or duplex type), Conrad deep-groove or spherical roller thrust bearings are recommended, depending on the requirements of the application. Filling-slot (maximum-load) antifriction bearings shall not be used in any motor. The manufacturer shall note thrust bearings of other construction. Where the motor shaft is solidly coupled to the driven apparatus, the thrust capacity of the thrust bearing shall be sufficient to carry the weight of the rotating element of the motor and the external axial thrust loads (in either or both directions) as well as the radial load specified.
- d) Bearings shall be selected to provide an L-10 life of 100,000 hours minimum for direct-connected loads per ABMA 9-1990 or ABMA 11-1990, as applicable. L-10 life calculations for vertical motors shall consider applicable thrust loading.
- e) Antifriction bearings shall have a dN factor of less than 300 000. [The dN factor is the product of bearing size (bore) in millimeters and the rated speed in revolutions per minute.]
- f) Bearings shall be suitable for, and supplied with, rust-inhibiting grease. The grease used and relubrication intervals shall be in accordance with motor manufacturers requirements. The minimum acceptable relubrication period should be 2years.

### 6.2 Rotor and Shaft

6.2.1 Rotor construction shall be of internal permanent magnets.

6.2.2 Maximum permissible shaft runout on shaft extensions

The maximum permissible shaft runout on shaft extensions (see Section 4 of NEMA MG 1-2011), when measured at the end of the shaft extension on the assembled motor, shall be as follows:

- a) 0.0508 mm (0.002 in) total indicator reading (TIR) for shafts 0.476cm to 4.13 cm (0.1875 in to 1.625 in) in diameter (inclusive)
- b) 0.0762 mm (0.003 in) TIR for shafts 4.13 cm to 16.5 cm (1.625 in to 6.5 in) in diameter (inclusive)

### 6.3 Frames and end shields

- a) Frames shall be made up of steel stator core laminations and VPI epoxy sealed. End shields shall be of cast iron construction.
- b) A drilled and tapped hole for a ground lug shall be provided on the motor frame, external to and on the same side as the terminal box.
- c) All fully assembled motors with mounting feet shall have a maximum coplanar tolerance of 0.127 mm (0.005 in) when measured in accordance with Section 4.15 of NEMA MG 1-2011.
- d) The draft angle of the top surface of the motor foot in the area surrounding the mounting bolt hole shall be a maximum of 1.5°.

### 6.4 Main terminal boxes and terminal leads

#### 6.4.1 Motors shall have a main terminal box of stainless steel construction, and the following additional requirements shall apply:

- a) Terminal boxes shall be rated IP 66 as a minimum, and supplied with a tapped conduit entrance hole(s) or a blank plate for field drilling.
- b) Conduit entry shall be on the bottom of the terminal box.
- c) Terminal box volume shall, as a minimum, meet or exceed the volume requirements of the NEC.
- d) The internal temperature of the terminal box shall allow use of 75 °C rated supply conductors.
- e) A moisture and oil resistant barrier shall be provided at the point where the leads exit the frame into the terminal box.
- f) A grounding lug shall be included in the main terminal box.
- g) Stator winding lead terminals shall be of the copper alloy seamless compression type and shall be connected to a terminal block in the connection box.

### 6.5 Drains

Corrosion-resistant, replaceable automatic drainage fittings shall be provided at the low point(s) of the motor enclosure for water drainage.

### 6.6 Hardware

Fasteners shall be hex-head bolts or socket-head cap screws. Screwdriver slot fasteners shall not be used. Shouldered eyebolts or other suitable means for lifting shall be provided. Threads shall be in accordance with ASME B 1.1-2003.

## 6.7 Airborne sound

- a) Motor sound pressure level shall not exceed 60 dB A at 3 feet determined in accordance with NEMA MG 1-2011, Part 9.7.
- b) Motor sound tests shall be taken at no load and at rated speed on an ASD so that the motor sound can be isolated from other sound sources.

## 6.8 Vibration

All fully assembled motors shall meet the levels of vibration below when tested at no load on elastic mounting per NEMA MG 1-2011, Part 7, or when bolted to a heavy, flat base whose natural frequency with motor mounted is removed by at least 25% from the motor speeds and frequencies referenced below:

- a) Motor unfiltered vibration at rated voltage and frequency shall not exceed 1.52 mm/s (0.06 in/s) peak velocity, when measured in any direction on the bearing housing and tested uncoupled with 0.5 height key in the shaft extension key way.
- b) Motor filtered vibration at rated voltage and frequency shall not exceed 1.27 mm/s (0.05 in/s) peak at frequencies of  $2n$  (twice speed) or  $2f$  (twice frequency).
- c) Motor unfiltered axial vibration shall not exceed 1.52 mm/s (0.06 in/s) peak on bearing housings. This limit shall not apply to roller bearings.

## 7. Corrosion-resistant treatment

### 7.1 Frame paint

Motor frames, end shields, fan covers, and terminal housings shall meet the test requirements of A.2.

The coating system is rated for C3 corrosive environments and is to include a primer coat over the varnished frame, an intermediate coat of 2.5mils (minimum) of two part epoxy, and a finish coat of two component epoxy for additional minimum build of 2.5 mils.

### 7.2 Assembly

The machined frame-to-end shield joints shall be protected by applying a corrosion-preventive material to the machined surfaces before assembly.

### 7.3 Exposed internal stator, rotor, and shaft surfaces

- a) Exposed internal stator, rotor, and shaft surfaces shall be protected against moisture and corrosion by a suitable protective coating.

- b) In order to provide protection during transportation and storage the exposed drive end shaft shall be provided with an easily removable protective coating.

#### 7.4 Miscellaneous

Assembly hardware for the motor and terminal box, grease fittings, and associated piping (if provided) shall meet the test requirements of A.3.

#### 8. Efficiency

Motor efficiency, when requested by the operator, shall be determined by dynamometer testing.

#### 9. Tests

##### 9.1 Factory tests

The following tests shall be performed on all motors prior to shipment from the factory.

- a) Measurement of winding resistance
- b) Open circuit voltage.
- c) Mechanical vibration check in accordance with 6.9, using either elastic or rigid mount
- d) High-potential test in accordance with Paragraph 12.3 of NEMA MG 1-2011, Part 12

##### 9.2 Additional tests

Additional tests may be specified by the purchaser.

##### 9.3 Test information supplied with motor

Winding resistance; open circuit voltage; and five unfiltered vibration readings (velocity) shall be supplied with the motor at the time of shipment. Vibration measurements shall include two readings, perpendicular to each other, in the radial plane on both ends of the motor (near each bearing) plus one axial reading.

##### 9.4 Prototype tests

Refer to Annex A for prototype test requirements.

#### 10. Nameplate

##### 10.1 Nameplate marking

A stamped, embossed, or etched nameplate shall be provided; and the information given on the nameplate shall include the following specifications in addition to the information noted in Section 10.40.1 a. through j. of NEMA MG 1-2011:

- a) ABMA bearing identification number



b) Manufacturer date or date code

c) Motor weight

## 10.2 Nameplate material

The nameplate material and its fastenings shall be of stainless steel meeting the test requirements of A.4.

## 11. Space heaters—requirements

The ASD shall be capable of providing trickle DC current to the motor windings to keep the motor interior free from condensation eliminating the need for the addition of space heaters. This feature shall also lock the rotor to prevent “wind milling”.

When trickle current to prevent condensation is not acceptable, space heaters may be specified. When specified, space heaters shall

a) Maintain the temperature of the winding at not less than 5 °C above outside ambient temperature

b) Avoid raising the motor insulation temperature in excess of 155 °C

c) Voltage as specified, single-phase ac operation

d) Identify heater leads by the letter H (if more than two terminal leads are brought out, they should be designated H1, H2, H3, H4, etc.)

e)

NOTE—Section 501-125(b) of the NEC requires the exposed surface of space heaters, when operated at rated voltage in a 40 °C ambient temperature, not to exceed 80% of the ignition temperature in degrees Celsius of the gas or vapor involved. The user shall specify the maximum heater surface temperature required for compliance with the NEC.

## 12. Data exchange—user and manufacturer

Annex B contains a data sheet for specifying ac permanent magnet synchronous motors, 370 kW (500 hp) and below, that comply with requirements in this standard.

## Annex A (informative)

### Prototype motor tests

The following tests shall be utilized in testing for motor performance and resistance to corrosion and humidity. They are initial design or prototype tests and not production tests. The test results shall be made available upon request.

#### A.1 Performance tests

The manufacturer shall run the following performance tests for the maximum rating of each frame diameter produced:

- a) Bearing and winding temperature rise tests at rated horsepower
- b) Determination of full load current
- c) Determination of efficiency at 100%, 75%, and 50% of full load
- d) Determination of power factor at 100%, 75%, and 50% of full load
- e) Airborne sound pressure level (If we change to sound pressure, change this)

#### A.2 Frame paint corrosion resistance (external surface)

The manufacturer shall perform the corrosion resistance test specified in ASTM B 117-97 for 96 hours. At the end of the 96 hours, the frame paint system shall exhibit continuous adhesion, without lifting, and no visible corrosion except at high points of castings.

#### A.3 Miscellaneous parts corrosion resistance

The manufacturer shall perform the corrosion resistance test specified in ASTM B 117-97 for 96 hours. At the end of the 96 hours, miscellaneous parts shall have no visible signs of corrosion except at high points of castings.

#### A.4 Nameplate corrosion resistance

The manufacturer shall perform the corrosion resistance test specified in ASTM B 117-97 for 720 hours. At the end of the 720 hours, the nameplate and its fastenings shall have no visible signs of corrosion.

#### A.5 Insulation system humidity resistance

The manufacturer shall perform the following test to determine the humidity resistance of the stator winding insulation system: The stator shall be exposed for 168 hours in a 40 °C closed chamber, in which an open water vessel is maintained at an elevated temperature, resulting in 100% relative humidity plus condensation on stator windings. Insulation resistance at the end of the test shall be not less than 5 MΩ (measured with a 500 V meg ohmmeter at 1 min), at or corrected to 40 °C. It may be necessary to provide some variation in water and air temperature to maintain visible condensation.

## Annex B (informative)

### Motor data sheet

Figure B.1 shows a motor data sheet, which should be used in conjunction with this specification to properly specify your motor.

**Figure B.1 - Motor Data Sheet for CT841-2012**

User: \_\_\_\_\_ EPC: \_\_\_\_\_ OEM: \_\_\_\_\_  
 Project: \_\_\_\_\_ Location: \_\_\_\_\_ Tag No: \_\_\_\_\_

Specification: CT841-2012     RFQ     Proposal     As Built

Altitude: \_\_\_\_\_ ft  
 Ambient: Max \_\_\_\_\_ °C    Min \_\_\_\_\_ °C  
 Area Class: \_\_\_\_\_ Group: \_\_\_\_\_ Div: \_\_\_\_\_  
 Nonhazardous    T Code: \_\_\_\_\_

**Motor info:**

Rating: \_\_\_\_\_ HP    \_\_\_\_\_ Max RPM  
 Insulation: Class H, VPI    Winding: Random  
 Enclosure: TEAO    Vertical, shaft:  up  down  
 SF: 1.0    Thrust load: \_\_\_\_\_ lbs  up  down  
 Space heaters: Y / N    Max surface temp \_\_\_\_\_ °C  
 Space heater leads:  main box     auxiliary box  
 Winding RTDs, 2/ph, 100 ohm: Y / N  
 Bearing RTDs, 1/brg, 100 ohm: Y / N  
 Shaft Requirements:    Straight Shaft: Y / N

Diam: \_\_\_\_\_ in +/- \_\_\_\_\_ in    Keyway: \_\_\_\_\_ X

Tapered Shaft: Y / N

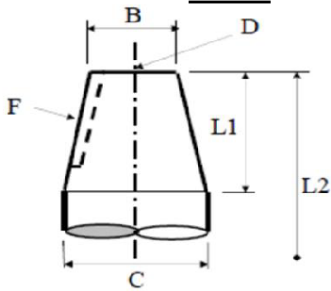

B= \_\_\_\_\_ in  
 C= \_\_\_\_\_ in  
 D= \_\_\_\_\_ drill and tap  
 F= \_\_\_\_\_ X \_\_\_\_\_ in  
 L1= \_\_\_\_\_ in  
 L2= \_\_\_\_\_ in

Testing:	Required	Witnessed
Factory test per 9.2	<input type="checkbox"/>	<input type="checkbox"/>
Shop inspection		<input type="checkbox"/>
Full load test	<input type="checkbox"/>	<input type="checkbox"/>
Noise test	<input type="checkbox"/>	<input type="checkbox"/>
Test with job ASD	<input type="checkbox"/>	<input type="checkbox"/>
Additional testing:	_____	
	_____	
	_____	
	_____	

**Fan Information:**

Fan Diameter: \_\_\_\_\_ ft    Fan Speed: \_\_\_\_\_ RPM  
 Air Flow: \_\_\_\_\_ cfm    Static Press: \_\_\_\_\_ in of H2O  
 Fan Shaft HP: \_\_\_\_\_ HP    Air Density: \_\_\_\_\_ lb/ft<sup>3</sup>  
 Fan Mfg: \_\_\_\_\_    Fan P/N: \_\_\_\_\_  
 No of fan blades: \_\_\_\_\_    Height Restriction: Y / N  
 Dist "A" motor/gear base to bottom of fan: \_\_\_\_\_ in

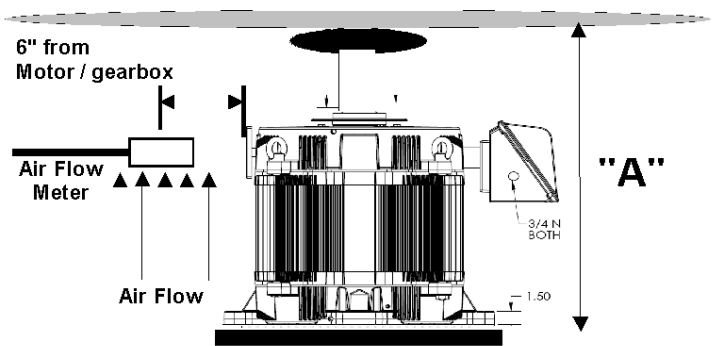

**For Retrofit:**

Existing motor: \_\_\_\_\_ HP    \_\_\_\_\_ RPM  
 Gearbox mfg: \_\_\_\_\_    P/N: \_\_\_\_\_  
 Gear ratio: \_\_\_\_\_    Match existing bolt pattern: Y / N  
 (If yes, supply drawing of existing gearbox)  
 Airflow 6" from gearbox vertical surface: \_\_\_\_\_ ft/min

**ASD info:**

Approximate cable length from motor to ASD: \_\_\_\_\_ ft  
 Drive location:  control room     other (specify below)  
 Incoming power: Phase/Hz/Volts: 3 / /

Additional requirements / notes:

\_\_\_\_\_  
 \_\_\_\_\_  
 \_\_\_\_\_  
 \_\_\_\_\_  
 \_\_\_\_\_