

WP0058

**Dodge® fluid coupling mechanical soft starts: basic information**

Dodge Customer/Order Engineering

12-14-2000



For many years, customers have used mechanical soft start devices, such as the Dodge Flexidyne product, to provide smooth and repeatable starts for their machinery. To diversify the soft start product line, a line of fluid couplings was introduced in 1996. The Dodge Fluid coupling compliments the Flexidyne product line by allowing customers to use a mechanical soft start device on larger horsepower applications. The Dodge fluid coupling uses a hydraulic fluid medium to transmit torque from the prime mover to the load in a driven system. Fluid coupling are capable of dampening vibrations from the driving equipment, such as a diesel engine. As such, the Dodge Fluid coupling can be used with applications requiring NEMA B motors and diesel Engines.

The fluid coupling is considered a “soft start” device since the motor shaft (prime mover) starts essentially under no load. The inner impeller produces the only external load on the motor shaft. This enables the motor to reach maximum speed under virtually no load. The load speed will lag the motor speed until the load approaches operating speed. Fluid couplings are generally placed on the high-speed side of the application. The fluid coupling is basically comprised of three major components: inner impeller (rotor), outer impeller (housing), and fluid medium as shown in **Figure 1**. The inner impeller is connected to the motor shaft. The outer impeller is connected to the load.

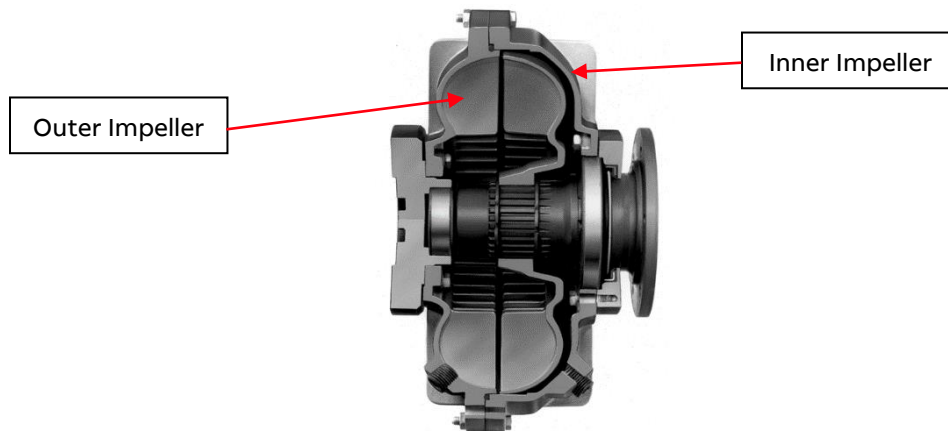

**Figure 1.** Fluid coupling section view

Fluid couplings operate on the principles of hydrokinetic transmission. The power is transmitted from the prime mover to the load through hydraulic fluid. The inner impeller acts as a centrifugal pump. The outer impeller acts as a hydraulic turbine. When the prime mover is started, the inner impeller blades exert kinetic energy on the fluid. Centrifugal force moves the fluid across the outer impeller blades. The outer impeller absorbs the kinetic energy and develops a torque equal to the input torque (Input Torque = Output Torque). There is no mechanical connection between the driving and driven shafts. To operate properly, slip must exist in the unit. Slip is the percent difference between the input speed (motor speed) and the output speed.

$$\% \text{ Slip} = \frac{\text{Input Speed} - \text{Output Speed}}{\text{Input Speed}} \times 100\%$$

**Formula 1**

**EXTERNAL/PUBLIC DOCUMENT**

ABB Motors and Mechanical Inc.  
 6040 Ponders Court  
 Greenville, SC 29615  
 Phone: +1 864 284 5700  
 Email: [DodgeEngineering@abb.com](mailto:DodgeEngineering@abb.com)

Under normal operating conditions % slip:

1.5% max slip for larger units

6.0% max slip for small units

### **Fluid Coupling Benefits**

1. Soft cushioned starts to smoothly accelerate the load.
2. Ensures motor does not exceed 200% nominal torque rating when unit is 100% full of fluid.
3. Starting torque can be limited to 160% by reducing quantity of fluid in unit.
4. Minimizes operating costs by reducing current draw on motor at startup.
5. Motor is sized based on running or operating torque instead of starting torque.
6. Protects against mechanical and electrical overloads.
7. Output torque is equivalent to input torque.
8. High efficiency (94% to 98.5%).
9. Absorbs torsional vibration induced by prime mover (i.e. Diesel Engine).
10. Eliminates need for special motors used on applications with high inertia loads.
11. Allows load sharing with multi-motor drives.
12. Motor synchronization is unnecessary.

Please refer to the Dodge Fluid Coupling instruction manual (MN4051) and Dodge PT Components Engineering Catalog (CA4000) for more information about Dodge Fluid Couplings. The article, "Dodge Fluid Couplings Provide Cost-Effective Soft Starts", published in the Summer 1996 edition of the Dodge Report introduces the Dodge fluid coupling product line. Also, the article, "Dodge Fluid Couplings A Powerful Advantage", published in the Spring 1998 edition of the Dodge Report introduces fluid coupling basics and thermal protection devices for Dodge fluid couplings. The article, "Dodge Fluid Couplings Provide The Solution For A Debarking Drum Project", published in the Spring 1998 edition of the Dodge Report presents a fluid coupling solution for a multi-motor drive application.

### **EXTERNAL/PUBLIC DOCUMENT**

**ABB Motors and Mechanical Inc.**

6040 Ponders Court

Greenville, SC 29615

Phone: +1 864 284 5700

Email: [DodgeEngineering@abb.com](mailto:DodgeEngineering@abb.com)