

DODGE® Smart Housings

These instructions must be read thoroughly before installation or operation.

DODGE Smart Housings

Dodge Smart Housings are supplied with an embedded temperature sensor. The housings are also predrilled and tapped for mounting temperature and speed kits which are ordered separately.

USAF Housings with Temperature Sensor Kits*

Note: If the speed sensing feature is not going to be used, screws and plugs are supplied with the housing. After applying RTV to the screws and plugs, the screws and plugs should be torqued into the predrilled holes in the cast closed end. Torque #10 screws to 65–75 in-lb and 12mm plug to 30–35 in-lb.

Smart Housings have a machined surface on the housing cap with a temperature sensor embedded in the housing cap, drilled and tapped for mounting transmitter, and four drilled and tapped #10–32 holes to mount the sensor kits. Care should be taken in handling not to damage the thermocouple or temperature switch leads. Follow the Installation Manual (MN3032) supplied with the sensor kits for mounting and wiring instructions. If a thermocouple or temperature switch are not required, a sharp knife or wire cutters can be used to remove the leads without harming the Smart Housing.

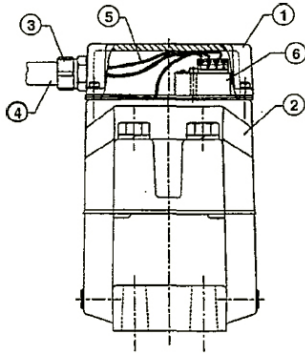

Figure 1: USAF Housing with Thermocouple

* Sensor Kits are ordered separately.

USAF Housings for Use with Speed Sensor Kits*

The cast closed side of the housing is predrilled for four #10–32 mounting screws and one 12mm proximity switch. Follow the Installation Manual (MN3032) supplied with the sensor kit for mounting and wiring instructions. The proximity probe is to be used only on the cast closed end of the housing on the nonexpansion bearing assembly. For shaft sizes up to 5", misalignment must not exceed $\pm 1/2^\circ$. Misalignment for larger shaft sizes should not exceed $\pm 1/4^\circ$.

WARNING: Because of the possible danger to person(s) or property from accidents which may result from the improper use of products, it is important that correct procedures be followed. Products must be used in accordance with the engineering information specified in the catalog. Proper installation, maintenance and operation procedures must be observed. The instructions in the instruction manual must be followed. Inspections should be made as necessary to assure safe operation under prevailing conditions. Proper guards and other suitable safety devices or procedures as may be desirable or as may be specified in safety codes should be provided, and are neither provided by Baldor Electric Company nor are the responsibility of Baldor Electric Company. This unit and its associated equipment must be installed, adjusted, and maintained by qualified personnel who are familiar with the construction and operation of all equipment in the system and the potential hazards involved. When risk to person(s) or property may be involved, a holding device must be an integral part of the driven equipment beyond the speed reducer output shaft.

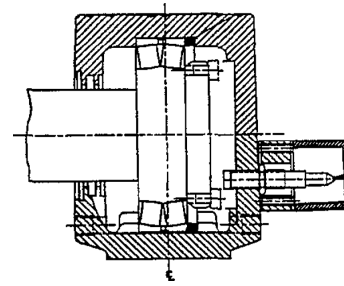

Figure 2: USAF Housing with Speed Kit

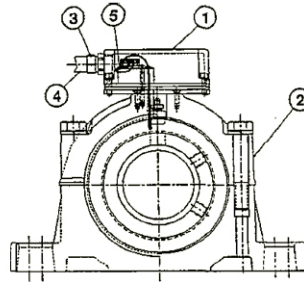

Figure 3: TAF Housing with Thermocouple

TAF Temperature Kits*

The TAF Smart S-1 units have the temperature sensors embedded to monitor bearing temperature. TAF Smart housings are predrilled to accept a mounting plate and screws shipped with all housings that require a larger mounting surface for sensor kits than the housing provides. This mounting plate has two holes for securing the plate to the housing, one hole through which the thermocouple should be threaded, one clearance hole for the temperature transmitter and four #10–32 tapped holes to mount the sensor kits. Once the mounting plate is secured to the housing follow the Installation Manual (MN3032) supplied with the sensor kit for mounting and wiring instructions.

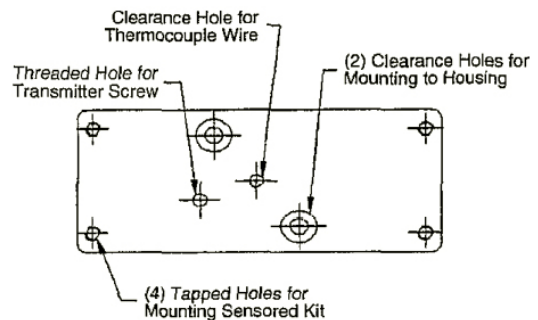

Figure 4: TAF/ISAF Mounting Plate

* Sensor Kits are ordered separately.



FITTING OR REPLACING A SMART S-1 UNIT IN A PILLOW BLOCK

WARNING: To ensure that drive is not unexpectedly started, turn off and lock out or tag power source before proceeding. Failure to observe these precautions could result in bodily injury.

1. Match marks have been stamped on the mating faces of the cap and base of each outer housing. When reassembling pillow block make sure match marks on cap and base match. At this time do not remove shims found between the cap and base.
2. If installing a new S-1 unit in an existing outer housing go to step 3. To fit a S-1 unit in a new outer housing one of the three .007" shims on each joint surface of the housing should be replaced with one .005 shim supplied with the S-1 unit.
3. Lubricate bearing seat on the cap and on the base of the outer housing with an anti-seize compound.
4. Fit each S-1 unit to its outer housing by placing the unit in the pillow block base and install cap with temperature sensor lead wires from the S-1 unit so they line up with the recessed machined in the outer smart housing cap lube hole area. Tighten cap bolts to specified torque in Table 1.
5. Check assembly for "snug" fit by prying against lubrication stud in unit through the lubrication hole in housing cap with a screwdriver or small pinch bar.
6. The "snug" fit becomes a matter of judgment. A "loose or sloppy" fit may allow a unit mount to move in its outer housing thus wearing the mating surfaces. Too "tight" a fit will not allow the unit to move and compensate for misalignment and for shaft deflection caused by belt pull and dead weight.
7. With shims supplied with Smart S-1 Unit add or remove shims between cap and base as required to obtain "snug" fit of unit in outer housing with cap bolts tightened to specified torque in Table 1.

TAF S-1 Units for Use with Speed Sensor Kits*

The face of the S-1 unit housing is predrilled and tapped for mounting the Speed Sensor End Cover. A proximity switch based Speed Sensor Kit is required for monitoring the speed of the bearing. Mount the bearing per the bearing installation instructions and tighten the proximity collar set screw before mounting the end cover. To mount the Speed Sensor End Cover, apply RTV on the end cover, place the end cover against the mounting surface on the housing, and secure the cover in place using the screws supplied with the end cover kit. After the end cover is secured to the housing, follow the installation Note supplied with the sensor kit for mounting and wiring instructions.

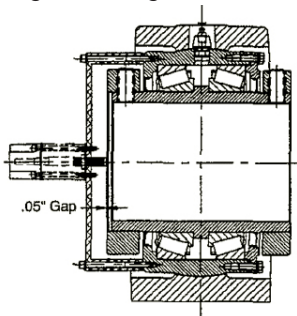

Figure 5: TAF housing with Speed Kit

Table 1 – Cap Bolt Torque
(Non-Expansion & Expansion)

Bore Size (In.)	2 Bolt Base		4 Bolt Base	
	Bolt Size	Torque Ft.-Lbs.	Torque Bolt Size	Ft.-Lbs.
2-7/16-2-1/2	1/2-13	60-75	1/2-13	60-75
2-11/16-3	5/8-11	120-150	5/8-11	120-150
3-7/16-3-1/2	3/4-10	208-260	3/4-10	208-260
3-15/16-4	-	-	3/4-10	208-260
4-7/16-4-1/2	-	-	7/8-9	344-430
4-15/16-5	-	-	1-8	512-640
5-7/16-6	-	-	1-8	512-640
6-7/16-7	-	-	1-8	512-640

ISAF Housings with Temperature Sensor Kits

The ISAF Smart housings have the temperature sensors imbedded in the housing cap to monitor the bearing temperature. Some ISAF Smart housings require a mounting plate to provide a larger mounting surface for the temperature sensor kit. If required, the ISAF Smart housings come with the mounting plate installed on the top of the housing. This mounting plate has two holes for securing the plate to the housing, a hole through which the thermocouple should be threaded, a threaded hole for the temperature transmitter, and four #10-32 tapped holes to mount the sensor kits. Each sensor kit contains installation manuals for mounting and wiring instructions.

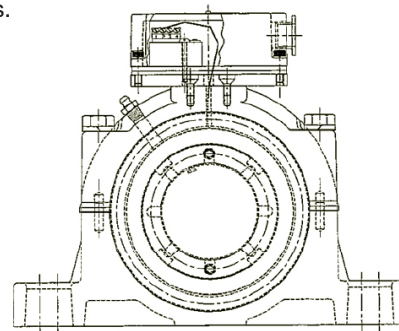

Figure 6: ISAF Housing with Thermocouple

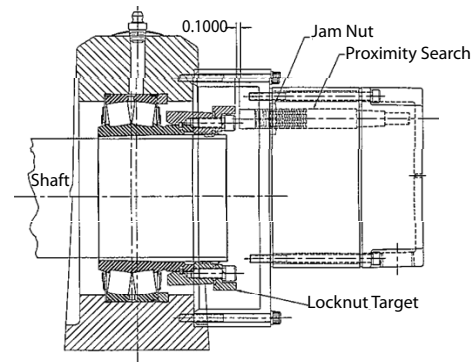

Figure 7: ISAF Housing with Speed Kit



World Headquarters

P.O. Box 2400, Fort Smith, AR 72902-2400 U.S.A., Ph: (1) 479.646.4711, Fax (1) 479.648.5792, International Fax (1) 479.648.5895

Dodge Product Support

6040 Ponders Court, Greenville, SC 29615-4617 U.S.A., Ph: (1) 864.297.4800, Fax: (1) 864.281.2433

www.baldor.com

© Baldor Electric Company
MN3031 (Replaces 499040)



All Rights Reserved. Printed in USA.
3/10 TCP 10,000