

TIGEAR-2® Output Shaft Reversal Instructions

These instructions must be read thoroughly before installing or operating this product.

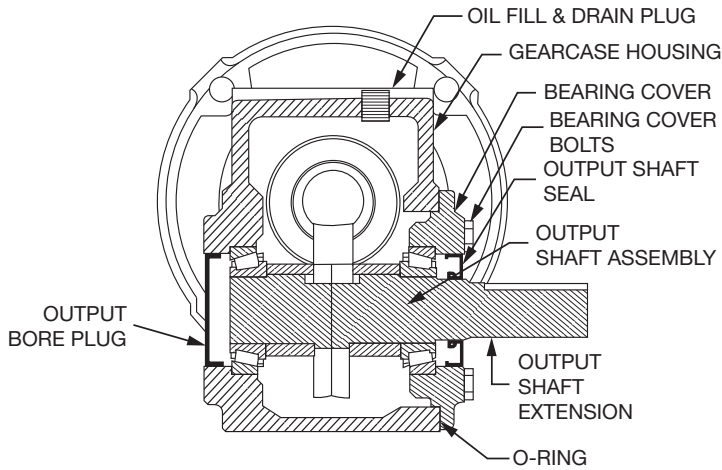

SHAFT POSITION "L"

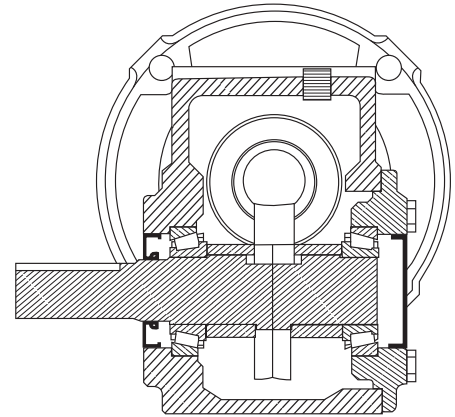

SHAFT POSITION "R"

CAUTION: Shaft Reversal Must Be Performed By Individuals Familiar With Disassembly And Assembly Of Worm Gear Products. A New Output Shaft Seal And Output Bore Plug Must Be Used When Performing A Shaft Reversal. Improperly Performed Reversals Or Reversals Done Without A New Seal And Plug Will Not Be Covered Under Warranty.

INSTALLATION:

1. Remove the oil fill and drain plug in the top of the reducer and completely drain the oil from the reducer into a clean container.
2. Lay the reducer on its side with the bearing cover facing up.
3. Loosen and remove the (4) bearing cover bolts and lockwashers.
4. Rotate the bearing cover sufficiently to be able to get a screw driver between the bearing cover and gearcase housing.

WARNING: Because of the possible danger to persons(s) or property from accidents which may result from the improper use of products, it is important that correct procedures be followed: Products must be used in accordance with the engineering information specified in the catalog. Proper installation, maintenance and operation procedures must be observed. The instructions in the instruction manuals must be followed. Inspections should be made as necessary to assure safe operation under prevailing conditions. Proper guards and other suitable safety devices or procedures as may be desirable or as may be specified in safety codes should be provided, and are neither provided by Baldor Electric Company nor are the responsibility of Baldor Electric Company. This unit and its associated equipment must be installed, adjusted and maintained by qualified personnel who are familiar with the construction and operation of all equipment in the system and the potential hazards involved. When risk to persons or property may be involved, a holding device must be an integral part of the driven equipment beyond the speed reducer output shaft.

5. Remove the bearing cover using two flat-blade screwdrivers. Keep the bearing cup and shims together and do not mix the shims with any shims that might be installed with the bearing cup on the opposite end of the output shaft.
6. Lift out the output shaft assembly and place it on a clean surface.
7. Remove and discard the output shaft seal, taking care not to damage the machined bore in the bearing cover or gearcase housing.
8. Remove and discard the output bore plug, taking care not to damage the machined bore in the bearing cover or gearcase housing.
9. Remove and keep together the remaining tapered bearing cup and any shims.
10. If changing to Shaft Position "L," clean the bore in the gearcase housing and install a new output bore plug in the gearcase housing. Clean the bore in the bearing cover and install a new output shaft seal in the bearing cover. Install the plug and seal 1/16" below flush with the outside of the gearcase or bearing housing.
11. If changing to Shaft Position "R," clean the bore in the gearcase housing and install a new output shaft seal in the gearcase housing. Clean the bore in the bearing cover and install a new output bore plug. Install the plug and seal 1/16" below flush with the outside of the gearcase or bearing housing.
12. Remove and keep together the tapered bearing cup and shims from the bearing cover and place them in the gearcase housing bore. Place the tapered bearing cup and shims that were previously removed from the gearcase housing and place them in the bearing cover.

- Wrap vinyl electrical tape around the entire output shaft extension to protect the lip seal during assembly. Do not extend the tape onto the portion of the shaft which the seal contacts during operation.

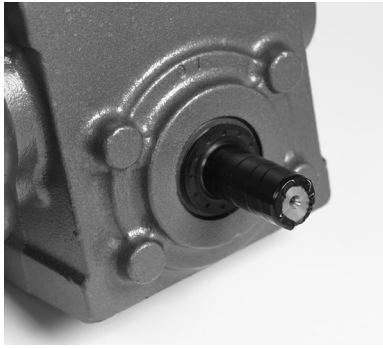

- Apply a small amount of reducer oil drained in Step 1 to the taped shaft extension to help slide the extension through the output seal. If the reducer is being changed to Shaft Position "R", place the reducer housing on blocks to provide room for the shaft extension. Insert the output shaft assembly, shaft extension down, into the reducer housing. If the reducer is being changed to Shaft Position "L", insert the output assembly, shaft extension up, into the reducer housing.
- Remove the original o-ring from the bearing cover and install a new o-ring.
- Install the bearing cover onto the gearcase housing. If the bearing cup and shims fall out of the bearing cover, apply a liberal amount of oil to the bearing cup's outside diameter and reinstall the bearing cup and shims into the bearing cover. The oil will hold the parts in the bearing cover.

- Install the four bearing cover bolts and lockwashers and torque the bolts in a cross pattern to the following values:

Reducer Size	Bolt Torque (Inch - Pounds)
13	75
15	75
17	156
20	156
23	276
26	276
30	420
35	420
40	1320
47	1320

- Remove the vinyl electrical tape from the output shaft extension and place the reducer with the fill and drain plug hole facing up.
- Fill the reducer with the oil drained in Step 1. Install and tighten the oil fill and drain plug. Standard temperature range replacement lubricant is available from Dodge. Contact Dodge Product Support for details.

CAUTION: Do not substitute or add any other kind of oil or premature reducer failure may occur.

BALDOR®

A MEMBER OF THE ABB GROUP

P.O. Box 2400, Fort Smith, AR 72902-2400 U.S.A., Ph: (1) 479.646.4711, Fax (1) 479.648.5792, International Fax (1) 479.648.5895

Dodge Product Support

6040 Ponders Court, Greenville, SC 29615-4617 U.S.A., Ph: (1) 864.297.4800, Fax: (1) 864.281.2433

www.baldor.com

