

# Installation and Parts Replacement Manual for DODGE® Torque-Arm™ TXT Double Reduction Taper Bushed and Straight Bore Speed Reducers

TXT/HXT 1A  
TXT/HXT 2A  
TXT/HXT 3C  
TXT/HXT 4C

TXT/HXT 5C  
TXT/HXT 6A  
TXT/HXT 7A

TXT 8A  
TXT 9A  
TXT 10A

Includes Char-Lynn 6B Hydroil Reducers

HXT 3C – 6B  
HXT 4C – 6B

HXT 5C – 6B  
HXT 6A – 6B

HXT 7A – 6B

These instructions must be read thoroughly before installation or operation. This instruction manual was accurate at the time of printing. Please see [baldor.com](http://baldor.com) for updated instruction manuals.

**Note!** The manufacturer of these products, Baldor Electric Company, became ABB Motors and Mechanical Inc. on March 1, 2018. Nameplates, Declaration of Conformity and other collateral material may contain the company name of Baldor Electric Company and the brand names of Baldor-Dodge and Baldor-Reliance until such time as all materials have been updated to reflect our new corporate identity.

**WARNING:** To ensure the drive is not unexpectedly started, turn off and lock-out or tag power source before proceeding. Failure to observe these precautions could result in bodily injury.

**WARNING:** All products over 25 kg (55 lbs) are noted on the shipping package. Proper lifting practices are required for these products.

**WARNING:** Because of the possible danger to person(s) or property from accidents which may result from the improper use of products, it is important that correct procedures be followed. Products must be used in accordance with the engineering information specified in the catalog. Proper installation, maintenance and operation procedures must be observed. The instructions in the instruction manuals must be followed. Inspections should be made as necessary to assure safe operation under prevailing conditions. Proper guards and other suitable safety devices or procedures as may be desirable or as may be specified in safety codes should be provided, and are neither provided by ABB nor are the responsibility of ABB. This unit and its associated equipment must be installed, adjusted and maintained by qualified personnel who are familiar with the construction and operation of all equipment in the system and the potential hazards involved. When risk to persons or property may be involved, a holding device must be an integral part of the driven equipment beyond the speed reducer output shaft.

## INSTALLATION:

1. Use lifting bracket where applicable to lift reducer.
2. Determine the running positions of the reducer. (See Fig. 1)

Note that the reducer is supplied with six plugs; four around the sides for horizontal installations and one on each face for vertical installations. These plugs must be arranged relative to the running positions as follows:

**Horizontal Installations** - Install the magnetic drain plug in the hole closest to the bottom of the reducer. Install the filter/ventilation plug in topmost hole. Of the two remaining plugs on the sides of the reducer, the lowest plug is the minimum oil level plug.

**Vertical Installations** - Install the filter/ventilation plug in the hole provided in the upper face of the reducer housing. If space is restricted on the upper face, install the vent in the highest hole on the side of the reducer per Figure 1 using the optional vertical vent kit. Install a plug in the hole in the bottom face of the reducer. Do not use this hole for the magnetic drain plug. Install the magnetic drain plug in the lowest hole on the sides of the reducer. Of the remaining holes on the sides of the reducer, use the plug in the upper housing half for the minimum oil level plug,

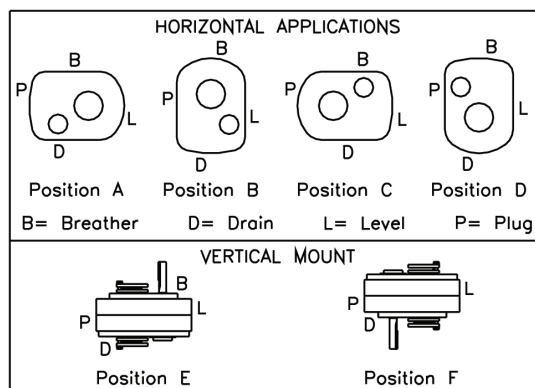

Figure 1 - Mounting Positions

Below 15 RPM output speed, oil level must be adjusted to reach the highest oil level plug. If reducer position is to vary from those shown in Figure 1, either more or less oil may be required. Consult Dodge.

The running position of the reducer in a horizontal application is not limited to the four positions shown in Fig. 1. However, if running position is over 20° in position “B” & “D” or 5° in position “A” & “C”, either way from sketches, the oil level plug cannot be used safely to check the oil level, unless during the checking, the torque arm is disconnected and the reducer is swung to within 20° for position “B” & “D” or 5° for position “A” & “C” of the positions shown in Fig. 1. Because of the many possible positions of the reducer, it may be necessary or desirable to make special adaptations using the lubrication filling holes furnished along with other standard pipe fittings, stand pipes and oil level gauges as required.

3. Mount reducer on driven shaft as follows:

**WARNING: To ensure that drive is not unexpectedly started, turn off and lock out or tag power source before proceeding. Remove all external loads from drive before removing or servicing drive or accessories. Failure to observe these precautions could result in bodily injury.**

**For Taper Bushed Reducer:** Mount the reducer on the driven shaft per instruction sheet for the tapered bushing kit.

4. Install sheave on input shaft as close to reducer as practical. (See Fig. 2)
5. If not using a Dodge Torque-Arm motor mount, install motor and V-belt drive so belt will approximately be at right angles to the centerline between driven and input shaft. (See Fig. 3) This will permit tightening the V-belt with the torque arm.
6. Install torque arm and adapter plates using the long reducer bolts. The adapter plates may be installed in any position around the input end of the reducer.
7. Install torque arm fulcrum on a flat and rigid support so that the torque arm will be approximately at right angles to the centerline through the driven shaft and the torque arm anchor screw. (See Fig. 4) Make sure that there is sufficient take-up in the turnbuckle for belt tension adjustment when using V-belt drive.

**CAUTION: Unit is shipped without oil. Add proper amount of recommended lubricant before operating. Failure to observe this precaution could result in damage to or destruction of the equipment.**

8. Fill gear reducer with the recommended volume of lubricant.

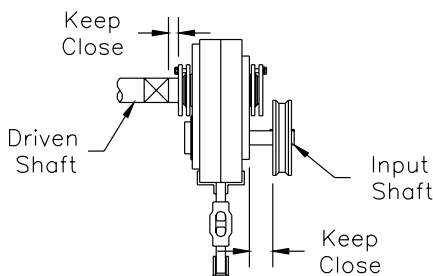

**Figure 2 - Reducer and Sheave Installation**

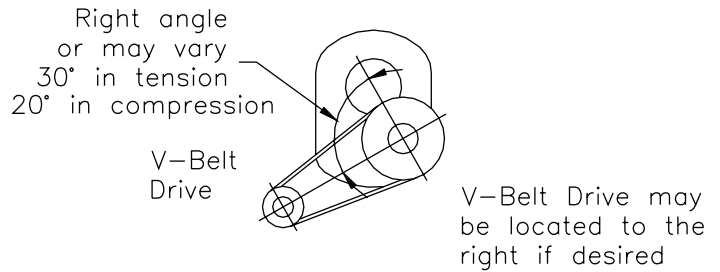

**Figure 3 - Angle of V-Drive**

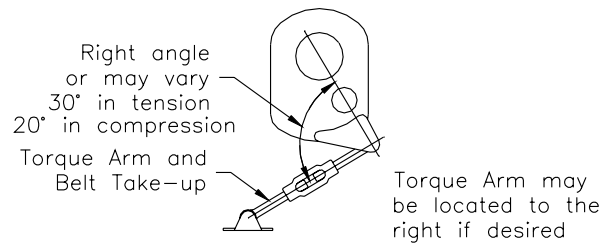

**Figure 4 - Angle of Torque Arm**

### TXT TAPERED BUSHING INSTALLATION

**WARNING: To ensure that drive is not unexpectedly started, turn off and lock out or tag power source before proceeding. Remove all external loads from drive before removing or servicing drive or accessories. Failure to observe these precautions could result in bodily injury.**

#### Taper Bore Bushings:

1. One bushing assembly is required to mount the reducer on the driven shaft. An assembly consists of two tapered bushings, bushing screws and washers, and necessary shaft keys or key.

The driven shaft must extend through the full length of the reducer. The minimum shaft length, as measured from the end of the shaft to the outer edge of the bushing flange (see Figure 5), is given in Table 1. This dimension does not include dimension “A”. Dimension “A” should be added to the minimum shaft length to allow for the removal of the bushings at disassembly.

2. Place one bushing, flange end first, onto the driven shaft and position per dimension “A”, as shown in Table 1. This will allow the bolts to be threaded into the bushing and for future bushing and reducer removal. If the reducer must be positioned closer to the equipment than dimension “A”, place the screws, with washers installed, into the unthreaded holes of the bushing flange prior to placing the bushing on the shaft and position as required.
3. Insert the output key in the shaft and bushing. For ease of installation, rotate the driven shaft so that the shaft keyseat is at the top position.
4. Mount the reducer on the driven shaft and align the shaft key with the reducer hub keyway. Maintain the recommended minimum distance “A” from the shaft bearing.

5. Insert the screws, with washers installed, in the unthreaded holes in the bushing flange and align with the threaded holes in the bushing backup plate. If necessary, rotate the bushing backup plate to align with the bushing screws. Tighten the screws lightly. If the reducer must be positioned closer than dimension "A", place the screws with washers installed, in the unthreaded holes in the bushing before positioning reducer making sure to maintain at least 1/8" between the screw heads and the bearing.
6. Place the second tapered bushing in position on the shaft and align the bushing keyway with the shaft key. Align the unthreaded holes in the bushing with the threaded holes in the bushing backup plate. If necessary, rotate the bushing backup plate to align with the bushing holes. Insert bushing screws, with washers installed in the unthreaded holes in the bushing. Tighten screws lightly.
7. Alternately and evenly tighten the screws in the bushing nearest the equipment to the recommended torque given in Table 1. Repeat procedure on outer bushing.

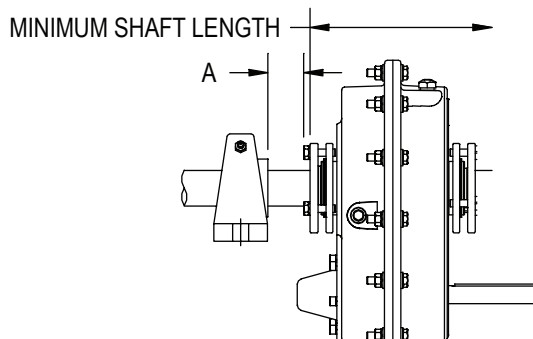

**Figure 5 - Minimum Recommended Dimensions**

Table 1 - Minimum Mounting Dimensions and Bolt Torques		
Minimum Required Shaft Length		
Reducer Size	Taper Bushing	Straight Bushing
TXT1A	6-1/2	5-5/8
TXT2A	6-3/4	5-13/16
TXT3C	8-9/16	7-11/16
TXT4C	9-5/16	8-1/4
TXT5C	9-3/4	8-11/16
TXT6A	10-3/4	9-5/8
TXT7A	11-15/16	10-3/4
TXT8A	13-1/8	11-3/8
TXT9A	13-0	11-3/8
TXT10A	14-3/16	12-3/8

Bushing Screw Information and Minimum Clearance for Removal			
Reducer Size	Fastener Size	Torque in In.-Lbs.	Dim. "A"
TXT1A	5/16-18	200	1-1/4
TXT2A	5/16-18	200	1-1/4
TXT3C	3/8-16	200	1-1/2
TXT4C	3/8-16	360	1-3/4
TXT5C	3/8-16	360	1-13/16
TXT6A	1/2-13	360	1-13/16
TXT7A	1/2-13	800	2-1/16
TXT8A	1/2-13	800	2-1/16
TXT9A	1/2-13	900	2-7/16
TXT10A	5/8-11	900	2-7/16

### Straight Bore Bushings:

1. One bushing assembly is required to mount the reducer on the driven shaft. An assembly consists of one keyed straight bushing, one plain straight bushing, required set screws, and necessary shaft key or keys. The driven shaft must extend through the reducer to operate properly. The minimum shaft length, as measured from the end of the shaft to the outer edge of the retaining collar, is given in Table 1.
2. Install the plain bushing into the reducer output hub on the side toward the equipment or bearing. Remove two short set screws from the retaining collar and install two of the longer set screws supplied with the bushing kit. Line up the bushing holes with the set screws. Thread the set screws in until they locate into the bushing holes. Make sure the set screws are threaded in only enough to locate the bushing in the reducer hub and does not extend thru the bushing.
3. Install the keyed bushing into the opposite end of the reducer hub as the plain bushing. Remove one short set screw from the retaining collar and install the remaining set screw from the bushing kit into the collar. Line up the bushing hole with the set screw. Thread the set screw in until it locates into the bushing hole. Make sure the set screw is threaded in only enough to locate the bushing in the reducer hub and does not extend through the bushing.
4. Mount the reducer on the driven shaft as close to the equipment or bearing as practical.
5. Line up the keyway in the bushing with the keyway in the driven shaft. Insert the key supplied with the bushing kit into the keyway. Gently tap the key into position until the key is flush with the edge of the reducer. Securely tighten all set screws.

### Standard Tapered Bushings Removal:

1. Remove bushing screws.
2. Place the screws in the threaded holes provided in the bushing flanges. Tighten the screws alternately and evenly until the bushings are free on the shaft. For ease of tightening screws make sure screw threads and threaded holes in the bushing flanges are clean. If the reducer was positioned closer than the recommended minimum distance "A" as shown in Table 1, loosen the inboard bushing screws until they are clear of the bushing flange by 1/8". Locate two (2) wedges at 180 degrees between the bushing flange and the bushing backup plate. Drive the wedges alternately and evenly until the bushing is free on the shaft.
3. Remove the outside bushing, the reducer, key(s), and inboard bushing.

## LUBRICATION

**IMPORTANT: Because Torque-Arm reducers are shipped without oil, it is extremely important to add the proper amount of lubricant prior to operating reducer. For most applications a high-grade petroleum-base rust and oxidation inhibited (R&O) gear oil is suitable. See Table 2 and Table 3 for proper oil volume and viscosity requirements.**

Under severe conditions EP oil can be used provided the reducer is not equipped with an internal backstop. Internal backstops are designed to rely on friction to operate correctly. EP lubricants contain friction modifiers that will alter backstop performance and therefore must not to be used on reducers equipped with internal backstops.

Follow instructions on reducer warning tags.

Lubrication is very important for satisfactory operation. The proper oil level must be maintained at all times. Frequent inspection, at least monthly, with the unit not running and allowing sufficient time for the oil to cool and the entrapped air to settle out of the oil should be made by removing the level plug and verifying the level is being maintained. If oil level is low, add the proper lubricant until the oil volume is increased to the correct level.

After an initial operation of about two weeks, the oil should be changed. If desired, this oil may be filtered and reused. After the initial break in period, under average industrial operating conditions, the lubricant should be changed every 2500 hours of operation. At every oil change, drain reducer and flush with kerosene, clean magnetic drain plug and refill to proper level with new lubricant.

Under extreme operating conditions, such as rapid rise and fall of temperature, dust, dirt, chemical particles, chemical fumes, or oil sump temperatures above 200°F, the oil should be changed every 1 to 3 months, depending on severity of conditions.

**CAUTION: Too much oil will cause overheating and too little will result in gear failure. Check oil level regularly. Failure to observe this precaution could result in equipment damage and/or bodily injury.**

Heating is a natural characteristic of enclosed gearing. A maximum gear case temperature approaching 200°F is not uncommon for some units operating in normal ambient temperatures of 80°F. When operating at the rated capacity with proper lubrication, no damage will result from this temperature. This maximum temperature was taken into consideration during the design of the reducer.

Reducer		Approximate Volume of Oil to Fill Reducer to Oil Level Plug ① ⑤ ⑥											
		② Position A		② Position B		② Position C		② Position D		② Position E		② Position F	
Size	Ratio	③ Qt	④ L	③ Qt	④ L	③ Qt	④ L	③ Qt	④ L	③ Qt	④ L	Qt	L
TXT1A	9,15,25	1/2	1/2	1/2	1/2	5/8	5/8	3/4	3/4	1	1	1-1/4	1-1/8
TXT2A	9,15,25	7/8	7/8	1	1	5/8	5/8	1	1	1-5/8	1-1/2	1-3/4	1-5/8
TXT3C	9,15,25	1-1/2	1-3/8	1-1/2	1-3/8	3/4	3/4	2-1/4	2-1/8	2-5/8	2-1/2	3	2-7/8
TXT4C	9,15,25	1-7/8	1-3/4	2-1/4	2-1/8	1-1/4	1-1/8	1-3/4	1-5/8	3-3/8	3-1/8	4-1/4	4
TXT5C	9,15,25	3-1/4	3-1/8	4	3-3/4	3-1/4	3-1/8	4	3-3/4	7	6-5/8	8-5/8	8-1/8
TXT6A	9,15,25	4-1/4	4	5	4-3/4	4-1/4	4	5	4-3/4	8-5/8	8-1/8	9-1/8	8-5/8
TXT7A	9,15,25	6-1/2	6-1/8	8	7-1/2	7-1/4	6-7/8	9-1/4	8-3/4	15-3/8	14-1/2	16-3/8	15-1/2
TXT8A	15,25	8-1/2	8	11	10-3/8	10-1/2	9-7/8	8-1/2	8	19-1/8	18-1/8	19-1/8	18-1/8
TXT9A	15,26	13	12-1/4	13	12-1/4	12-1/2	11-7/8	14-1/4	13-1/2	25-3/8	24	25-3/8	24
TXT10A	15,24	23	21-3/4	14	13-1/4	15-3/4	14-7/8	18-3/4	17-3/4	41	38-3/4	41	38-3/4

① Oil quantity is approximate. Service with lubricant until oil runs out of oil level hole.

② Refer to Figure 1 for mounting positions.

③ US measure: 1 quart = 32 fluid ounces = .94646 liters.

④ Conversion from quarts rounded values.

⑤ Below 15 RPM output speed, oil level must be adjusted to reach the highest oil level plug. If reducer position is to vary from those shown in Figure 1, either more or less oil may

be required. Consult Dodge.

⑥ Consult Dodge for proper oil level for reducers equipped with backstops and which are mounted in either the C position or D position.

**Table 3 - Oil Recommendations**

**ISO Grades For Ambient Temperatures of 50°F to 125°F (Refer to Notes below)**

Output RPM	Torque-Arm Reducer Size									
	TXT1A	TXT2A	TXT3C	TXT4C	TXT5C	TXT6A	TXT7A	TXT8A	TXT9A	TXT10A
301 – 400	320	320	220	220	220	220	220	220	220	220
201 – 300	320	320	220	220	220	220	220	220	220	220
151 – 200	320	320	220	220	220	220	220	220	220	220
126 – 150	320	320	320	220	220	220	220	220	220	220
101 – 125	320	320	320	320	220	220	220	220	220	220
81 – 100	320	320	320	320	320	220	220	220	220	220
41 – 80	320	320	320	320	320	220	220	220	220	220
11 – 40	320	320	320	320	320	320	320	320	320	320
1 – 10	320	320	320	320	320	320	320	320	320	320

**ISO Grades For Ambient Temperatures of 15°F to 60°F (Refer to Notes below)**

Output RPM	Torque-Arm Reducer Size									
	TXT1A	TXT2A	TXT3C	TXT4C	TXT5C	TXT6A	TXT7A	TXT8A	TXT9A	TXT10A
301 – 400	220	220	150	150	150	150	150	150	150	150
201 – 300	220	220	150	150	150	150	150	150	150	150
151 – 200	220	220	150	150	150	150	150	150	150	150
126 – 150	220	220	220	150	150	150	150	150	150	150
101 – 125	220	220	220	220	150	150	150	150	150	150
81 – 100	220	220	220	220	220	150	150	150	150	150
41 – 80	220	220	220	220	220	150	150	150	150	150
11 – 40	220	220	220	220	220	220	220	220	220	220
1 – 10	220	220	220	220	220	220	220	220	220	220

- Notes:
1. Assumes auxiliary cooling where recommended in the catalog.
  2. Pour point of lubricant selected should be at least 10°F lower than expected minimum ambient starting temperature.
  3. Extreme pressure (EP) lubricants are not necessary for average operating conditions. TORQUE-ARM internal backstops are not suitable for use with EP lubricants.
  4. Special lubricants may be required for food and drug industry applications where contact with the product being manufactured may occur. Consult a lubrication manufacturer's representative for his recommendations .
  5. For reducers operating in ambient temperatures between -22°F (-30°C) and 20°F (-6.6°C) use a synthetic hydrocarbon lubricant, 100 ISO grade or AGMA 3 grade (for example, Mobil SHC627) . Above 125°F (51°C), consult DODGE Gear Application Engineering (864) 284-5700 for lubrication recommendation .
  6. Mobil SHC630 Series oil is recommended for high ambient temperatures.

# OIL VISCOSITY EQUIVALENCY CHART

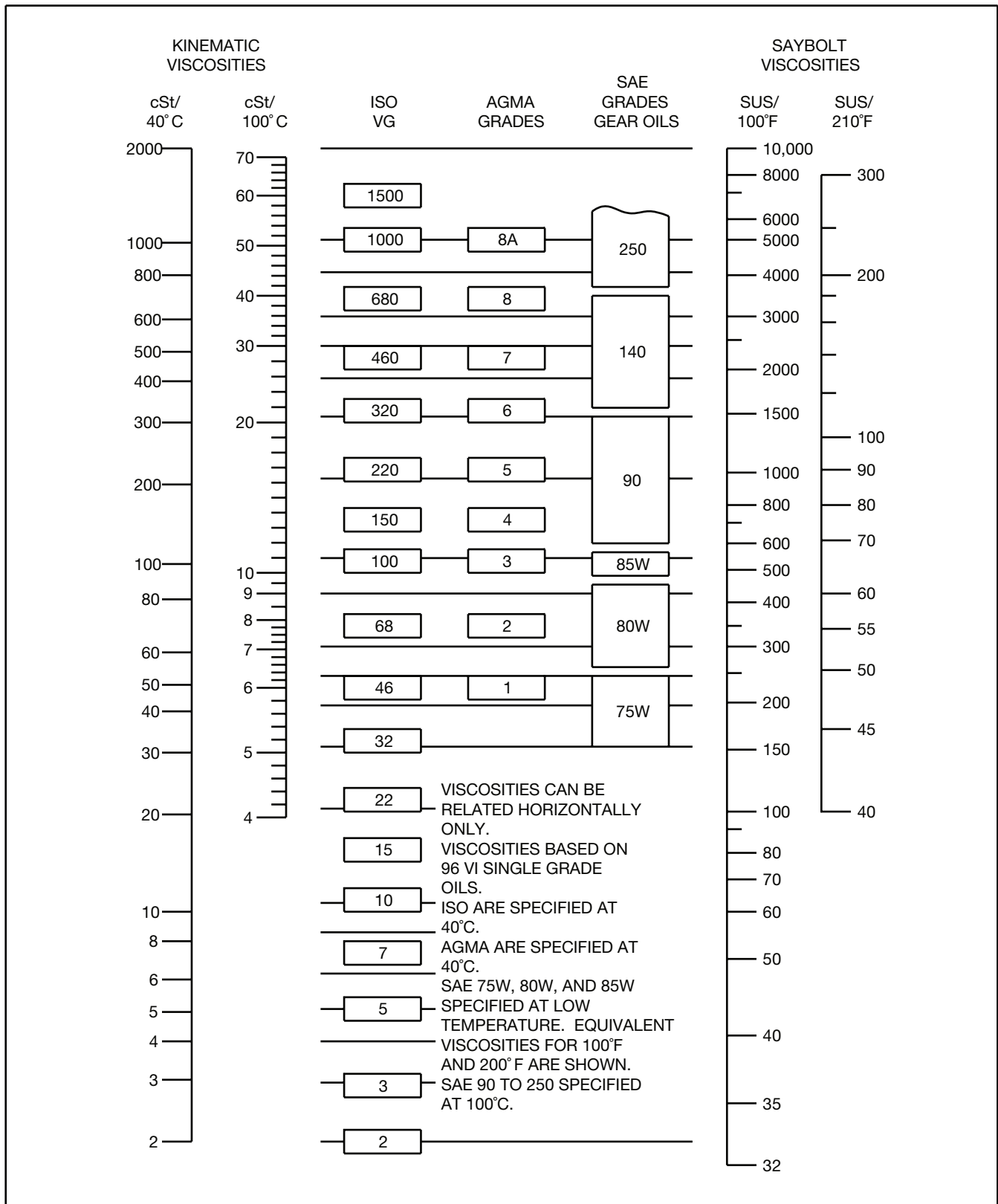

## GUIDELINES FOR TXT REDUCER LONG-TERM STORAGE

During periods of long storage, or when waiting for delivery or installation of other equipment, special care should be taken to protect a gear reducer to have it ready to be in the best condition when placed into service.

By taking special precautions, problems such as seal leakage and reducer failure due to lack of lubrication, improper lubrication quantity, or contamination can be avoided. The following precautions will protect gear reducers during periods of extended storage:

### Preparation:

1. Drain oil from the unit. Add a vapor phase corrosion inhibiting oil (VCI-105 oil by Daubert Chemical Co.) in accordance with Table 4.
2. Seal the unit airtight. Replace the vent plug with a standard pipe plug and wire the vent to the unit.
3. Cover all unpainted exterior parts with a waxy rust preventative compound that will keep oxygen away from the bare metal. (Non-Rust X-110 by Daubert Chemical Co. or equivalent)
4. The instruction manuals and lubrication tags are paper and must be kept dry. Either remove these documents and store them inside, or cover the unit with a durable waterproof cover which can keep moisture away.
5. Protect reducer from dust, moisture, and other contaminants by storing the unit in a dry area.
6. In damp environments, the reducer should be packed inside a moisture-proof container or an envelope of polyethylene containing a desiccant material. If the reducer is to be stored outdoors, cover the entire exterior with a rust preventative.

### When placing the reducer into service:

1. Fill the unit to the proper oil level using a recommended lubricant. The VCI oil will not affect the new lubricant.
2. Clean the shaft extensions with petroleum solvents.
3. Assemble the vent plug into the proper hole.

Follow the installation instructions provided in this manual.

Table 4 - Quantities of VCI #105 Oil	
Reducer Size	Quantity (Ounces / Milliliter)
TXT1A	1 / 30
TXT2A	1 / 30
TXT3C	1 / 30
TXT4C	1 / 30
TXT5C	1 / 30
TXT6A	2 / 59
TXT7A	2 / 59
TXT8A	3 / 89
TXT9A	4 / 118
TXT10A	6 / 177

VCI #105 and #10 are interchangeable.  
VCI #105 is more readily available.

## Motor Mounts

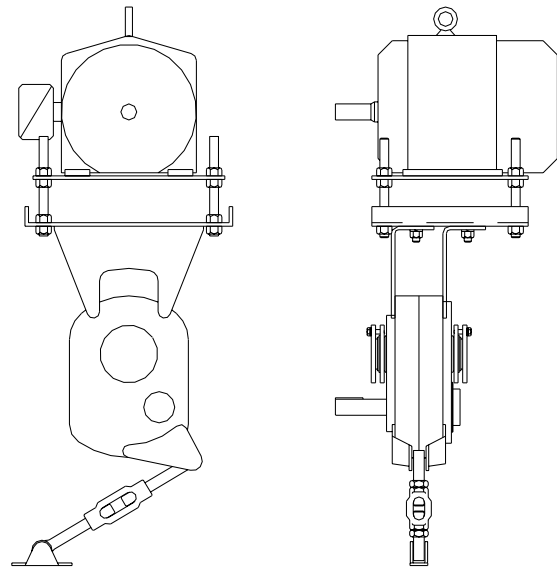

Figure 6 - Motor Mounts

**Warning: Belt guard removed for illustration purposes. Do not operate if belt guard is not in place.**

### Motor Mount Installation:

The TA motor mount is designed to be installed on the output end of the reducer as shown in Figure 6. If bottom mounting is desired, use the optional TAB style.

### TA1M thru TA7M Motor Mount:

Remove the required housing bolts on the output end of the reducer. Place the motor mount brackets in position and install the longer housing bolts supplied with the motor mount assembly. Do not fully tighten the housing bolts at this time.

Install the bottom plate to the motor mount brackets and tighten with the hardware provided. Next, tighten the housing bolts to the torque values listed in Table 6.

Install the four adjusting studs to the bottom plate using the jam nuts provided and securely tighten. These nuts will not require any further adjustment. Add one additional jam nut to each stud and thread approximately to the middle of the stud. Install the top motor plate on top of the jam nuts. Assemble the remaining jam nuts on studs to secure top motor plate. Do not fully tighten these nuts yet.

Mount motor, drive and driven sheaves, and v-belts.

**Note: Mount driven sheave as close to the reducer housing as practical.**

Adjust v-belts to the proper tension by adjusting the jam nuts and securely tighten.

Check all bolts to insure that they are securely tightened.

## TA8 thru TA10 Motor Mount:

Remove the required housing bolts on the output end of the reducer. Place the motor mount brackets in position and install the longer housing bolts supplied with the motor mount assembly. Do not fully tighten the housing bolts at this time.

Install the four adjusting studs to the top plate as shown using the jam nuts provided and securely tighten. Add one additional jam nut to each stud and thread approximately to the middle of the stud. Install this assembly to the motor mount brackets and install the remaining jam nuts onto the studs to secure the top plate to the brackets. Tighten the housing bolts to the torque values listed in Table 6.

Loosely install the front motor rail to the top plate. Measure the distance between the front and rear mounting holes on the motor and position the rear motor rail at this distance and loosely bolt to the top plate.

Center the motor on the motor rails and securely bolt the motor to the motor rails.

Install the motor sheave and reducer sheave on their shafts. Mount the reducer sheave as close to the housings as practical. Install the v-belts and adjust the motor rails to permit proper alignment of the v-belts to the sheaves. Securely tighten the motor rails to the mounting plate.

Adjust the v-belts to the proper tension and securely tighten the adjusting nuts.

Check all bolts to see that they are securely tightened.

**WARNING: To ensure that drive is not unexpectedly started, turn off and lock out or tag power source before proceeding. Remove all external loads from drive before removing or servicing drive or accessories. Failure to observe these precautions could result in bodily injury.**

## REPLACEMENT OF PARTS

**NOTE: Using tools normally found in a maintenance department, a Dodge Torque-Arm speed reducer can be disassembled and reassembled by careful attention to the instructions following.**

Cleanliness is very important to prevent the introduction of dirt into the bearings and other parts of the reducer. A tank of clean solvent, an arbor press, and equipment for heating bearings and gears (for shrinking these parts on shafts) should be available.

The oil seals are designed with a contact lip. Considerable care should be used during disassembly and reassembly to avoid damage to the surface on which the seals rub.

The keyseat in the input shaft, as well as any sharp edges on the output hub should be covered with tape or paper before disassembly or reassembly. Also, be careful to remove any burrs or nicks on surfaces of the input shaft or output hub before disassembly or reassembly.

### Ordering Parts:

When ordering parts for a Dodge Torque Arm reducer, specify reducer part number, part name, and quantity required.

It is strongly recommended that, when a pinion or gear is replaced, the mating pinion or gear is replaced also.

If the large gear on the output hub must be replaced, it is recommended that an output hub assembly consisting of a gear assembled on a hub be ordered to ensure undamaged surfaces on the output hub where the output seals rub. However, if it is desired to use the old output hub, press the gear and bearing off and examine the rubbing surface under the oil seal carefully for possible scratching or other damage resulting from the pressing operation. To prevent oil leakage at the shaft oil seals, the smooth surface of the output hub must not be damaged.

If any parts must be pressed from a shaft or from the output hub, this should be done before ordering parts to make sure that none of the bearings or other parts are damaged in removal. Do not press against rollers or cage of any bearing. Because old shaft oil seals may be damaged in disassembly, it is advisable to order replacements for these parts.

### Removing Reducer from Shaft:

**WARNING: To ensure that drive is not unexpectedly started, turn off and lock out or tag power source before proceeding. Remove all external loads from drive before removing or servicing drive or accessories. Failure to observe these precautions could result in bodily injury.**

### Taper Bushed Reducer:

1. Disconnect and remove belt guard, v-drive, and motor mount as required. Disconnect torque arm rod from reducer adapter.
2. Remove bushing screws.
3. Place the screws in the threaded holes provided in the bushing flanges. Tighten the screws alternately and evenly until the bushings are free on the shaft. For ease of tightening screws, make sure screw threads and threaded holes in bushing flanges are clean. A tap can be used to clean out the threads. Use caution to use the proper size tap to prevent damage to the threads.
4. Remove the outside bushing, the reducer, and then the inboard bushing.

### Straight Bore Reducer:

1. Disconnect and remove belt guard, v-drive, and motor mount as required. Disconnect torque arm rod from reducer adapter.
2. Loosen and remove the set screws in both output hub collars.
3. Remove the collar from the output hub closest to the end of the shaft. This will expose three puller holes in the output hub to permit the use of a three prong puller. In removing the reducer from the shaft, use care not to damage the reducer output hub.

### Disassembly:

1. Drain all oil from the reducer.
2. Remove all locking collars, retaining rings, and bushing backup plated as required. Position the reducer on its side and remove all housing bolts. Using the three pry slots around the periphery of the flange, gently separate the housing halves and open evenly to prevent damage to the parts inside. Remove the two dowel pins.
3. Lift input shaft, all gear assemblies, and bearing assemblies from housing.
4. Remove seals from housing.



- Remove bearings from shafts and hubs. Be careful not to scratch or damage any assembly or seal area during bearing removal. The hub assembly can be disassembled for gear replacement but if scratching or grooving occurs on the hub, seal leakage will occur and the hub will need to be replaced.

### TXT Reassembly:

- Output Hub Assembly: Heat gear to 325°F to 350°F to shrink onto hub. Heat bearings to 270°F to 290°F to shrink onto hub. Any damage to the hub surfaces where the oil seals rub will cause leakage, making it necessary to replace the hub.
- Countershaft Assembly: Heat gear to 325°F to 350°F and bearings to 270°F to 290°F to shrink onto shaft.
- Input Shaft Assembly: Heat bearings 270°F to 290°F to shrink onto shaft. Press bearings on shaft.
- Drive the two dowel pins into place in the right-hand housing half (backstop side).
- Place R.H. housing half on blocks to allow for protruding end of output hub.
- Install all bearing cups on TXT3C thru TXT10A in right-hand housing half, making sure they are properly seated. TXT1A and TXT2A reducers use ball bearings on all shafts and do not incorporate bearing cups.
- Mesh the output hub gear and small countershaft gear together and set in place in housing. Set input shaft assembly in place in the housing. Make sure bearing rollers (cones) are properly seated in their cups. Set bearing cups for left-hand housing half in place on their rollers.
- Make sure both housing halves are clean and free of RTV residue. For TXT sizes 1A, 2A, and 5C through 10A, apply a continuous 1/8" diameter bead of Dow Corning RTV732 sealant on the flange surface of the R.H. housing (make sure RTV is placed around all bolt holes). Do not apply RTV sealant to TXT size 3C and 4C reducers at this time. Set the left-hand housing half in position onto the dowel pins and gently tap with a soft hammer until housing bolts can be used to draw housing halves together. Make sure reducer shafts do not bind when tightening housing bolts. Torque housing bolts per torque values listed in Table 6. On TXT1A and TXT2A reducers, skip to step number 12.
- On TXT 1A and TXT2A reducers, skip to step number 12. Repeat step 9 above for installing and adjusting the countershaft and input bearings. Adjust the axial endplay per Table 5.
- For TXT sizes 3C and 4C, rotate the input shaft and set all bearings with a soft hammer. Using a magnetic base and indicator, measure and record the endplay of the input shaft, countershaft, and output hub. Remove the left housing half and shim behind the bearing cup as required to achieve the correct bearing endplay per Table 5. Repeat this process and check endplay until proper endplay is obtained.

For TXT sizes 5C through 10A, install the output seal carrier and draw down with two bolts 180° apart to 50 inch pounds of torque. Loosen both bolts then retighten finger tight only. Measure the clearance between the housing and carrier flange at each bolt and average the two values. Add 0.010" to the average reading and make up shim pack. Install shim pack between the carrier flange and reducer housing. Torque the bolts to the value shown in Table 6. Using a magnetic base and dial indicator, check the axial endplay reading of the output hub is per Table 5.

- Repeat step 10 above for adjusting the countershaft and input bearings. Adjust the axial endplay per Table 5.

Table 5 - Bearing Adjustment Tolerances			
Reducer Size	Bearing Endplay Values		
	Input	Countershaft	Output
TXT1A	N / A	N / A	N / A
TXT2A	N / A	N / A	N / A
TXT3C	.002-.004 Loose	.0005-.003 Loose	.0005-.003 Loose
TXT4C	.002-.004 Loose	.0005-.003 Loose	.0005-.003 Loose
TXT5C	.002-.004 Loose	.0005-.003 Loose	.0005-.003 Loose
TXT6A	.002-.004 Loose	.0005-.003 Loose	.0005-.003 Loose
TXT7A	.002-.004 Loose	.0005-.003 Loose	.0005-.003 Loose
TXT8A	.002-.004 Loose	.0005-.003 Loose	.0005-.003 Loose
TXT9A	.002-.004 Loose	.0005-.003 Loose	.0005-.003 Loose
TXT10A	.002-.004 Loose	.0005-.003 Loose	.0005-.003 Loose

Table 6 - Recommended Bolt Torque Values				
Recommended Torque Values (lbs.-ft.)				
Reducer Size	Housing Bolts	Output Seal Carrier	C/S Bearing Cover	Input Seal Carrier
TXT1A	30 - 27	N/A	N/A	N/A
TXT2A	30 - 27	N/A	N/A	N/A
TXT3C	50 - 45	17 - 15	17 - 15	17 - 15
TXT4C	50 - 45	30 - 27	30 - 27	30 - 27
TXT5C	75 - 68	30 - 27	30 - 27	30 - 27
TXT6A	75 - 68	30 - 27	30 - 27	30 - 27
TXT7A	150 - 135	30 - 27	50 - 45	50 - 45
TXT8A	150 - 135	30 - 27	30 - 27	30 - 27
TXT9A	150 - 135	30 - 27	30 - 27	30 - 27
TXT10A	150 - 135	30 - 27	30 - 27	30 - 27

Backstop Cover Bolt Recommended Torque Values		
Reducer Size	Fastener Size	Torque in Ft.-Lbs.
TXT1A	10 - 24 x 3/8	5 - 4
TXT2A	10 - 24 x 3/8	5 - 4
TXT3C	10 - 24 x 3/8	5 - 4
TXT4C	¼ - 20 x ½	8 - 7
TXT5C	¼ - 20 x ½	8 - 7
TXT6A	¼ - 20 x ½	8 - 7
TXT7A	¼ - 20 x ½	8 - 7
TXT8A	¼ - 20 x ½	8 - 7
TXT9A	¼ - 20 x ½	8 - 7
TXT10A	¼ - 20 x ½	8 - 7

## Replacement Part and Kit Numbers

Table 7 – Part Numbers for Replacement Bearings, Double Reduction Reducers		
Reducer Size	Output Hub Bearing – LH and RH Sides	
	Part Number	Manufacturer's Part Number
TXT1A	424020	6011NR
TXT2A	424022	6013NR
TXT3C	402272 / 403127	LM814849 / LM814810
TXT4C	402268 / 403163	498 / 492A
TXT5C	402193 / 403016	42381 / 42584
TXT6A	402050 / 403140	JM822049 / JM822010
TXT7A	402058 / 403111	48290 / 48220
TXT8A	402147 / 403105	36690 / 36620
TXT9A	402160 / 403110	46790 / 46720
TXT10A	402168 / 403116	67790 / 67720

Reducer Size	Input Shaft Bearing – LH Input Side	
	Part Number	Manufacturer's Part Number
TXT1A	424112	6205NR
TXT2A	424019	206NR
TXT3C	402204 / 403139	LM48548A / LM48510
TXT4C	402280 / 403027	2788 / 2720
TXT5C	402144 / 403104	28579 / 28521
TXT6A	402196 / 403091	395A / 3920
TXT7A	402150 / 403106	39590 / 39520
TXT8A	402098 / 403072	566 / 563
TXT9A	402114 / 403080	745A / 742
TXT10A	402114 / 403080	745A / 742

Reducer Size	Countershaft Bearing – LH Input Side	
	Part Number	Manufacturer's Part Number
TXT1A	424006	6304NR
TXT2A	424000	305NR
TXT3C	402273 / 403094	15102 / 15245
TXT4C	402000 / 403000	M86649 / M86610
TXT5C	402203 / 403027	2789 / 2720
TXT6A	402054 / 403159	HM807040 / HM807010
TXT7A	402256 / 403053	JHM807045 / JHM807012
TXT8A	402057 / 403143	JH211749 / JH211710
TXT9A	402109 / 403078	655 / 652A
TXT10A	402232 / 402231	JH415647 / JH415610

Reducer Size	Input Shaft Bearing – RH Backstop Side	
	Part Number	Manufacturer's Part Number
TXT1A	424111	6204NR
TXT2A	424090	6305NR
TXT3C	402273 / 403094	15102 / 15245
TXT4C	402142 / 403102	26118 / 26283
TXT5C	402266 / 403073	350A / 352
TXT6A	402197 / 403091	396 / 3920
TXT7A	402088 / 403047	455 / 452
TXT8A	402097 / 403072	565 / 563
TXT9A	402107 / 403076	639 / 633
TXT10A	402112 / 403080	745S / 742

Note: Bearing part numbers refer to Cup/Cone combinations, respectively, and apply to all ratios unless otherwise specified. For actual reducer ratios, refer to Table 9.

Reducer Size	Countershaft Bearing – RH Backstop Side	
	Part Number	Manufacturer's Part Number
TXT1A	424006	6304NR
TXT2A	424000	305NR
TXT3C	402273 / 403094	15102 / 15245
TXT4C	402000 / 403000	M86649 / M86610
TXT5C	402203 / 403027	2789 / 2720
TXT6A	402052 / 403142	HM803149 / HM803110
TXT7A	402256 / 403053	JHM807045 / JHM807012
TXT8A	402148 / 403106	39585 / 39520
TXT9A	402109 / 403078	655 / 652A
TXT10A	402232/402231	JH415647 / JH415610

Table 8 - Replacement Parts Kit Numbers							
Reducer Size	Ratio	Seal Kit	Output Hub Assembly		Countershaft Assembly	Bearing Kit(s)	Complete Shim Kit
			Taper Hub	Straight Hub			
TXT1A	9:1	392119	390878	390151	392100	389905 All	N/A
	15:1				392090		
	25:1				392091		
TXT2A	9:01	392120	392111	392110	392101	389906 All	N/A
	15:1				392092		
	25:1				392093		
TXT3C	9:1	389720	389703	389702	389729	392345 All	243800
	15:1				389700		
	25:1				389701		
TXT4C	9:1	389721	389710	389709	389730	392347 All	244800
	15:1				389707		
	25:1				389708		
TXT5C	9:1	389722	389717	389716	389731	392350 All	245139
	15:1				389714		
	25:1				389715		
TXT6A	9:1	246340	390935	390988	392140	335368 All	246166
	15:1				391171		
	25:1				391186		
TXT7A	9:1	247345	390941	390990	392141	392353 All	247138
	15:1				391196		
	25:1				391197		
TXT8A	15:1	248340	390944	390993	391184	392355 All	248111
	25:1				391185		
TXT9A	15:1	249340	390949	390159	390124	392357 All	249139
	26:1				390139		
TXT10A	15:1	272460	390954	390160	390983	392359 All	272610
	24:1				390998		

**Notes:**

Seal Kit consists of Input Seal, Output Seals, Backstop Cover Gasket and RTV Sealant.

Output Hub Assembly consists of Output Hub, Output Gear and Gear Key.

Countershaft Assembly consists of Countershaft Pinion, Countershaft Gear and Gear Key.

Bearing Kit consists of LH and RH Output Bearing Cup/Cone, LH and RH Countershaft Bearing Cup/Cone (double reduction only) and LH and RH Input Bearing Cup/Cone.

Complete shim kit consists of all input, countershaft, and output bearing shims

Table 9 - Actual Ratios			
Reducer Size	Nominal Ratios		
	9:1	15:1	25:1*
TXT1A	9.44	15.35	25.64
TXT2A	9.25	14.10	23.46
TXT3C	8.91	14.88	24.71
TXT4C	9.67	15.13	24.38
TXT5C	8.95	15.40	25.56
TXT6A	9.20	15.33	25.13
TXT7A	9.61	15.23	24.59
TXT8A	N/A	15.08	24.62
TXT9A	N/A	15.12	25.66
TXT10A	N/A	15.16	24.30

\* TXT9A is 26:1 Nominal Ratio and TXT10A is 24:1 Nominal Ratio

# Parts for TXT/HXT 1A & 2A Straight and Tapered Bushed Double Reduction Reducers

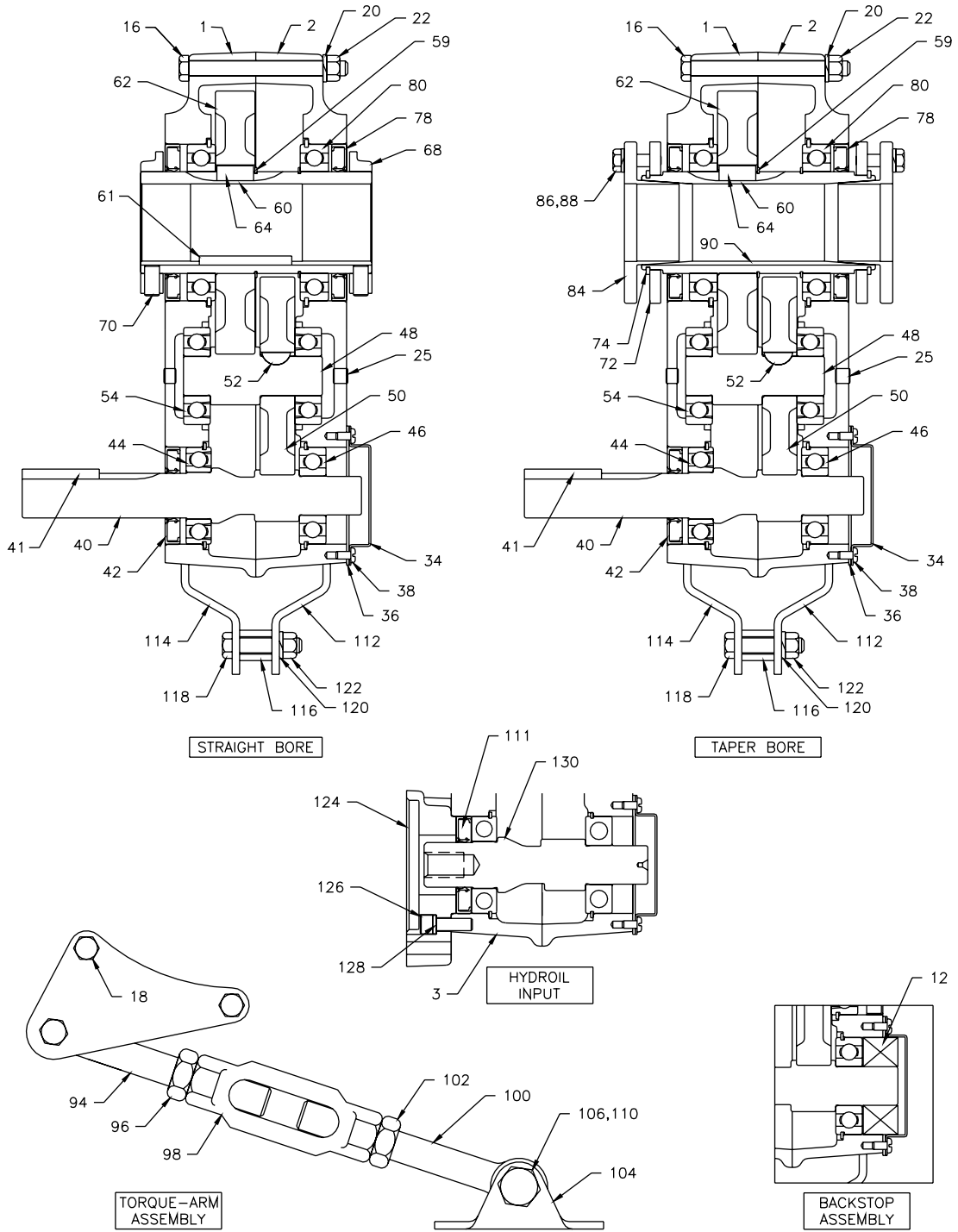

**Parts for TXT/HXT 1A & 2A Straight and Tapered Bushed Double Reduction Reducers**

Ref.	Description	Qty.	TXT/HXT 1A	TXT/HXT 2A	TXT3C HXT3C	TXT4C HXT4C
12	Backstop Assembly	1	242101	252101		
1	Housing-LH	1	241358	242353		
2	Housing-RH	1	241359	242354		
	Housing-RH, Flange Mount Drilled	1	241387	242393		
3	Housing-Hydroil LH	1	241064	242067		
①	RTV Sealant, Tube	1	465044	465044		
①	Air Vent	1	900287	900287		
16	Housing Bolt	⑦	411418	411418		
18	Housing Bolt-Adapter	2	411420	411420		
20	Lock-Washer	⑧	419011	419011		
22	Hex Nut	⑧	407087	407087		
①	Dowel Pin	2	420145	420145		
①	Magnetic Oil Plug	1	430060	430060		
25	Oil Plug	4	430031	430031		
34	Backstop Shaft Cover	1	242221	243221		
38	Backstop Cover Screw	4	415022	415022		
	Seal Kit ②	1	392119	392120		
36	Backstop Cover Gasket ④	1	242220	243220		
42	Input Oil Seal ④	1	241457	242211		
78	Output Hub Oil Seal ④	2	241210	242210		
40	Input Pinion					
	9:1 Ratio ⑥	1	241481	242481		
	15:1 Ratio ⑥	1	241302	242186		
	25:1 Ratio ⑥	1	241200	242187		
130	Hydroil Input Pinion					
	15:1 Ratio ⑥	1	241455	242188		
	25:1 Ratio ⑥	1	241449	242189		
41	Input Pinion Key	1	443008	443014		
	Bearing Replacement Kit ②	1	389905	389906		
44	Input Pinion Bearing-LH, Input Side ④	1	424112	424019		
46	Input Pinion Bearing-RH, Backstop Side ④	1	424111	424090		
54	Countershaft Pinion Bearing ④	2	424006	424000		
80	Output Hub Bearings ④	2	424020	424022		
	Countershaft Pinion Assembly ②					
	9:1 Ratio ⑥	1	392100	392101		
	15:1 Ratio ⑥	1	392090	392092		
	25:1 Ratio ⑥	1	392091	392093		
48	Countershaft Pinion ④	1	241216	242185		
50	First Reduction Gear ④					
	9:1 Ratio ⑥	1	241482	242482		
	15:1 Ratio ⑥	1	241170	242008		
	25:1 Ratio ⑥	1	241171	242005		
52	Countershaft to First Gear Key ④	1	241309	242218		
	Taper Bore Output Hub Assembly ②	1	390878	392111		
	Straight Bore Output Hub Assembly ③	1	390151	392110		
60	Output Hub					
	Straight Bore ⑤	1	241208	242208		
	Taper Bore ④	1	241265	242134		
62	Output Gear ④ ⑤	1	241007	242181		
64	Output Gear Key ④ ⑤	1	241217	443399		
59	Output Hub Snap Ring ④	2	421013	421017		
61	Straight Bore Output Hub Key ⑤	2	241296	242296		
68	Straight Bore Output Hub Collar	2	241209	242209		
70	Straight Bore Output Hub Collar Screw	4	400062	400094		
72	Taper Bore Bushing Backup Plate	2	241266	242137		
74	Bushing Backup Plate Retaining Ring	2	421111	421112		
84	Taper Bore Bushing Assembly ②					
	Bushing ④					
	1" Bore	1	241278	N/A		
	1-1/16" Bore	1	241280	N/A		
	1-1/8" Bore	1	241282	242146		
	1-3/16" Bore	1	241286	242148		
	1-1/4" Bore	1	241288	242150		
	1-5/16" Bore	1	241290	242152		
	1-3/8" Bore	1	241294	242154		
	1-7/16" Bore	1	241292	242156		
	1-11/16" Bore	1	N/A	242164		
	1-1/2" Bore	1	N/A	242158		
	1-5/8" Bore	1	N/A	242162		
	1-3/4" Bore	1	N/A	242166		
	1-15/16" Bore	1	N/A	242168		

Parts for TXT/HXT 1A & 2A Straight and Tapered Bushed Double Reduction Reducers						
Ref.	Description	Qty.	TXT/HXT 1A	TXT/HXT 2A		
86	Bushing Screw ④	6	411405	411390		
88	Lock Washer ④	6	419010	419010		
90	Key, Taper Bore Bushing to Shaft ④					
	1" Bore	1	443274	N/A		
	1-1/8" Bore	1	443271	443281		
	1-3/16" Bore	1	241308	443281		
	1-1/4" Bore	1	241307	443281		
	1-5/16" Bore	1	241306	443264		
	1-3/8" Bore	1	241310	443280		
	1-7/16" Bore	1	241305	443282		
	1-1/2" Bore	1	N/A	443282		
	1-5/8" Bore	1	N/A	424172		
	1-11/16"	1	N/A	242171		
	1-3/4" Bore	1	N/A	242170		
	1-15/16" Bore	1	N/A	443283		
①	Key, Bushing to Output Hub ④					
	1" Bore	1	443272	N/A		
	1-1/8" Bore	1	443273	N/A		
	1-1/8" to 1-1/2" Bore	1	N/A	443284		
94	Torque-Arm Assembly ②	1	241097	243097		
	Torque-Arm Rod End ④	1	241245	243245		
96	RH Nut ④	1	407093	407095		
98	Torque-Arm Turnbuckle ④	1	241246	243246		
100	Torque-Arm Extension ④	1	241247	243247		
102	LH Nut ④	1	407242	407244		
104	Torque-Arm Fulcrum ④	1	241249	243249		
106	Fulcrum Screw ④	1	411456	411484		
110	Hex Nut ④	1	407091	407093		
112	Adapter Assembly ②	1	259151	259152		
	RH Torque-Arm Adapter Bracket ④	1	241242	242136		
114	LH Torque-Arm Adapter Bracket ④	1	241241	242135		
116	Adapter Bushing ④	1	242243	243243		
118	Adapter Bolt ④	1	411412	411437		
120	Lock Washer ④	1	419011	419012		
122	Hex Nut ④	1	407087	407089		
124	Hydraulic Motor Adapter	1	241454	242454		
126	Adapter Screw	6	417081	417081		
128	Lockwasher	6	419046	419046		
111	Input Pinion Seal, Hydroil	1	241457	242457		
①	Motor to Adapter Screw	2	411408	411408		
①	Motor to Adapter Lock Washer	2	419011	419011		

Notes:

- ① Not shown on Drawing.
- ② Includes Parts Listed Immediately Below
- ③ Includes Parts Listed Immediately Below
- ④ Makes up Assembly Under Which it is Listed.
- ⑤ Makes up Assembly Under Which it is Listed.
- ⑥ See Table 9 for Actual Ratio.
- ⑦ 4 Required on TXT1A and 5 Required on TXT2A
- ⑧ 6 Required on TXT1A and 7 Required on TXT2A

# Parts for TXT3C, 4C Straight and Tapered Bushed Double Reduction Reducers

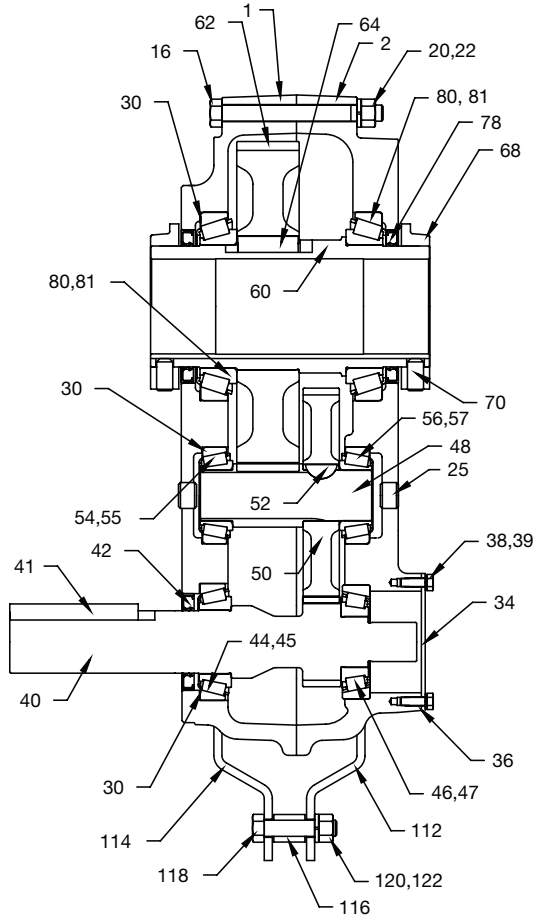

STRAIGHT BORE

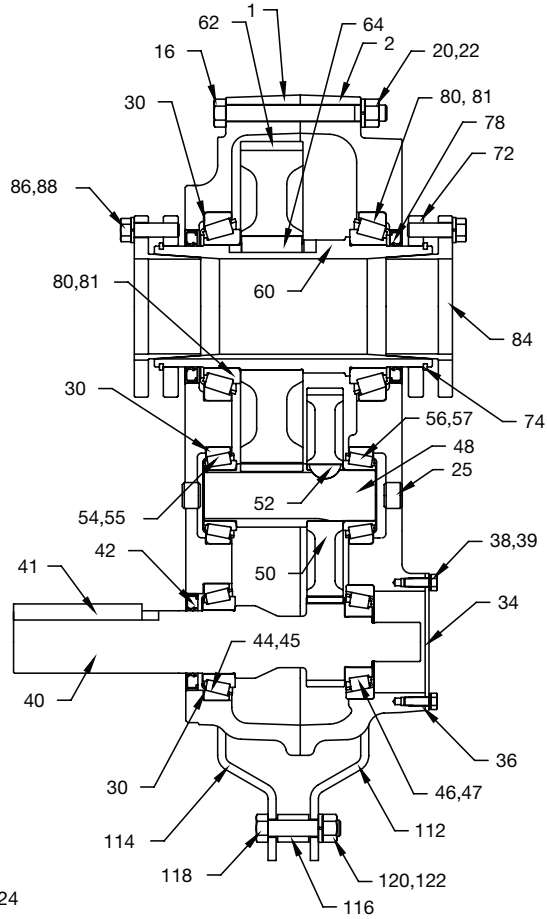

TAPER BORE

NOTE: THE TWO DIGIT NUMBERS ARE FOR REFERENCE ONLY. ORDER PARTS BY THE SIX DIGIT NUMBER IN THE PARTS LIST. EACH SIX DIGIT NUMBER IS A COMPLETE IDENTIFICATION OF THE PART OR ASSEMBLY.

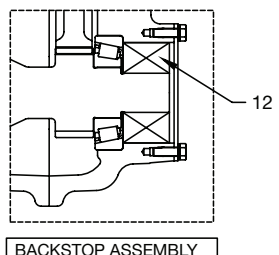

BACKSTOP ASSEMBLY

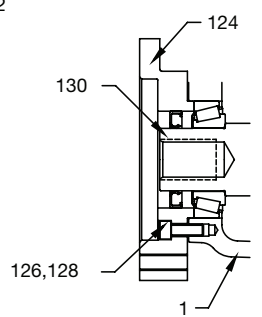

HYDROIL INPUT

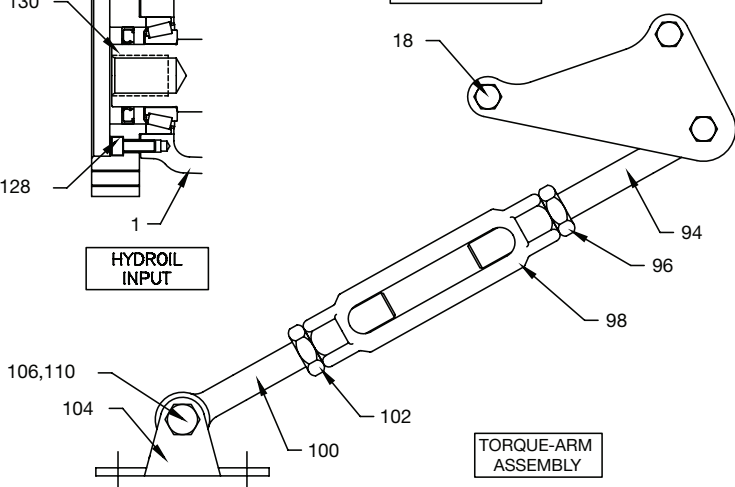

TORQUE-ARM ASSEMBLY

## Parts for TXT3C TXT4C Straight and Tapered Bushed Double Reduction Reducer

Ref.	Description	Qty.	TXT3C HXT3C	TXT4C HXT4C
12	Backstop Assembly	1	243106	244106
1	Housing - TXT and Hydroil LH	1	243244	244281
2	Housing-RH	1	243229	244366
	Housing-RH, Flange Mount Drilled	1	243384	244387
①	RTV Sealant, Tube	1	465044	465044
①	Air Vent	1	900287	900287
16	Housing Bolt	6	411440	411442
18	Housing Bolt-Adapter	2	411442	411444
20	Lock-Washer	8	419012	419012
22	Hex Nut	8	407089	407089
①	Dowel Pin	2	420146	420146
①	Magnetic Oil Plug	1	430060	430060
25	Oil Plug	4	430031	430031
28	Input Shaft Seal Carrier	1	N/A	N/A
30	Complete Shim Kit	1	243800	244800
32	Input Seal Carrier Screw	⑦	N/A	N/A
33	Lock Washer	⑦	N/A	N/A
34	Backstop Cover	1	243560	244493
38	Backstop Shaft Cover	4	416524	411035
39	Backstop Cover Screw	4	N/A	N/A
	Seal Kit ②	1	389720	389721
36	Backstop Cover Gasket ④	1	243561	244593
42	Input Pinion Shaft Seal ④	1	243558	244524
78	Output Hub Oil Seal ④	2	243578	244673
40	Input Pinion			
	9:1 Ratio ⑥	1	243549	244579
	15:1 Ratio ⑥	1	243550	244580
	25:1 Ratio ⑥	1	243551	244581
130	15:1 Ratio Hydroil Pinion ⑥	1	243553	244583
	25:1 Ratio Hydroil Pinion ⑥	1	243554	244584
	15:1 Ratio Hydroil 6-B Pinion ⑥	1	N/A	244586
	25:1 Ratio Hydroil 6-B Pinion ⑥	1	243498	244587
41	Input Pinion Shaft Key	1	443032	443082
	Input Bearing Kit ②	1	389587	389590
44	Input Shaft Bearing Cone, Input Side ④	1	402204	402280
45	Input Shaft Bearing Cup, Input Side ④	1	403139	403027
46	Input Shaft Bearing Cone, Backstop Side ④	1	402273	402142
47	Input Shaft Bearing Cup, Backstop Side ④	1	403094	403102
	Countershaft Pinion Assembly ②	1		
	9:1 Ratio ⑥	1	389729	389730
	15:1 Ratio ⑥	1	389700	389707
	25:1 Ratio ⑥	1	389701	389708
48	Countershaft Pinion ④	1	243555	244590
50	First Reduction Gear ④	1		
	9:1 Ratio ⑥	1	243237	244482
	15:1 Ratio ⑥	1	243238	244214
	25:1 Ratio ⑥	1	243239	244212
52	First Stage Gear Key ④	1	D8242	D8243
	Countershaft Bearing Kit ②	1	389588	389591
54	Countershaft Bearing Cone, Input Side ④	1	402273	402000
55	Countershaft Bearing Cup, Input Side ④	1	403094	403000
56	Countershaft Bearing Cone, Backstop Side ④	1	402273	402000
57	Countershaft Bearing Cup, Backstop Side ④	1	403094	403000
58	Countershaft Bearing Cover, Input Side ④	1	N/A	N/A
	Taper Bore Output Hub Assembly ②	1	389703	389710
	Straight Bore Output Hub Assembly ③	1	389702	389709
60	Output Hub			
	Straight Bore ⑤	1	243557	244589
	Taper Bore ④	1	243556	244588
62	Output Gear ④ ⑤	1	243570	244188
64	Output Gear Key ④ ⑤	1	243216	354087
68	Output Hub Collar, Straight Bore	2	243572	244658
70	Output Hub Collar Screw	4	400098	400150
72	Bushing Backup Plate, Taper Bore	2	243308	244099
74	Bushing Backup Plate Retaining Ring	2	421109	421108
76	Output Hub Seal Carrier, Input Side	1	N/A	N/A
	Output Hub Bearing Kit	1	389589	389592
80	Output Hub Bearing, Cone ④	2	402272	402268
81	Output Hub Bearing, Cup ④	2	403127	403163



**Parts for TXT3C thru TXT4C Straight and Tapered Bushed Double Reduction Reducer,  
continued**

Ref.	Description	Qty.	TXT3B HXT3B	TXT4B HXT4B
84	Taper Bore Bushing Assembly ② Bushing ④			
	1-5/16" Bore	1	243282	N/A
	1-3/8" Bore	1	243284	N/A
	1-7/16" Bore	1	243260	244079
	1-1/2" Bore	1	243262	244081
	1-5/8" Bore	1	243264	244083
	1-11/16" Bore	1	243268	244085
	1-3/4" Bore	1	243266	244087
	1-7/8" Bore	1	243270	244089
	1-15/16" Bore	1	243272	244093
	2" Bore	1	243274	244095
	2-1/8" Bore	1	N/A	244109
	2-3/16" Bore	1	243276	244111
	2-1/4" Bore	1	N/A	244113
	2-7/16" Bore	1	N/A	244115
	2-1/2" Bore	1	N/A	N/A
	2-11/16" Bore	1	N/A	N/A
	2-15/16" Bore	1	N/A	N/A
86	Taper Bushing Screw ④	6	411407	411408
88	Taper Bushing Lockwasher ④	6	419011	419011
90	Key, Bushing to Shaft ④			
	1-5/16" Bore	1	443264	N/A
	1-3/8" Bore	1	443264	N/A
	1-7/16" Bore	1	443265	443254
	1-1/2" Bore	1	443265	443254
	1-5/8" Bore	1	443265	443254
	1-11/16" Bore	1	443266	443254
	1-3/4" Bore	1	443266	443254
	1-7/8" Bore	1	443267	443255
	1-15/16" Bore	1	443269	443255
	2" Bore	1	443268	443255
	2-1/8" Bore	1	N/A	443258
	2-3/16" Bore	1	443270	443259
	2-1/4" Bore	1	N/A	443260
	2-7/16" Bore	1	N/A	443261
	2-1/2" Bore	1	N/A	N/A
	2-11/16" Bore	1	N/A	N/A
	2-15/16" Bore	1	N/A	N/A
①	Key, Bushing to Output Hub ④			
	1-3/4" thru 1-15/16" Bore Bushing	1	443262	N/A
	1-7/16" thru 2-1/4" Bore Bushing	1	N/A	N/A
	2-3/16" thru 2-15/16" Bore Bushing	1	N/A	443257
94	Torque-Arm Rod Kit ②	1	243097	245097
	Torque-Arm Rod End ④	1	243245	243245
96	RH Nut ④	1	407095	407095
98	Torque-Arm Turnbuckle ④	1	243246	243246
100	Torque-Arm Extension ④	1	243247	243247
102	LH Nut ④	1	407244	407246
104	Fulcrum ④	1	243249	243249
106	Fulcrum Screw ④	1	411484	411484
110	Hex Nut ④	1	407093	407093
112	Adapter Assembly ②	1	259153	259154
	RH Adapter Plate ④	1	243242	244244
114	LH Adapter Plate ④	1	243241	244243
116	Adapter Bushing ④	1	243243	245243
118	Adapter Bolt ④	1	411437	411460
120	Lockwasher ④	1	419012	419013
122	Hex Nut ④	1	407089	407091
124	Hydroil Motor Adapter	1	243539	244572
	15:1 Ratio Motor Adapter	1	243541	244572
	25:1 Ratio Motor Adapter	1	243467	244573
	Hydroil 6-B Motor Adapter, 15:1 and 25:1 Ratio	1	417081	417108
126	Adapter Screw	⑦	417081	417108
128	Lockwasher	⑦	419046	419047
①	Motor to Adapter Screw			
①	Motor to Adapter Lock Washer			

- Notes:  
 ① Not shown on drawing.  
 ② Includes parts listed immediately below  
 ③ Includes parts listed immediately below  
 ④ Makes up assembly under which it is listed.  
 ⑤ Makes up assembly under which it is listed.  
 ⑥ See Table 9 for actual ratio.  
 ⑦ 4 required on TXT3B and TXT4B, 5 required on TXT5C

# Parts for TXT5C Straight and Tapered Bored Double Reduction Reducers

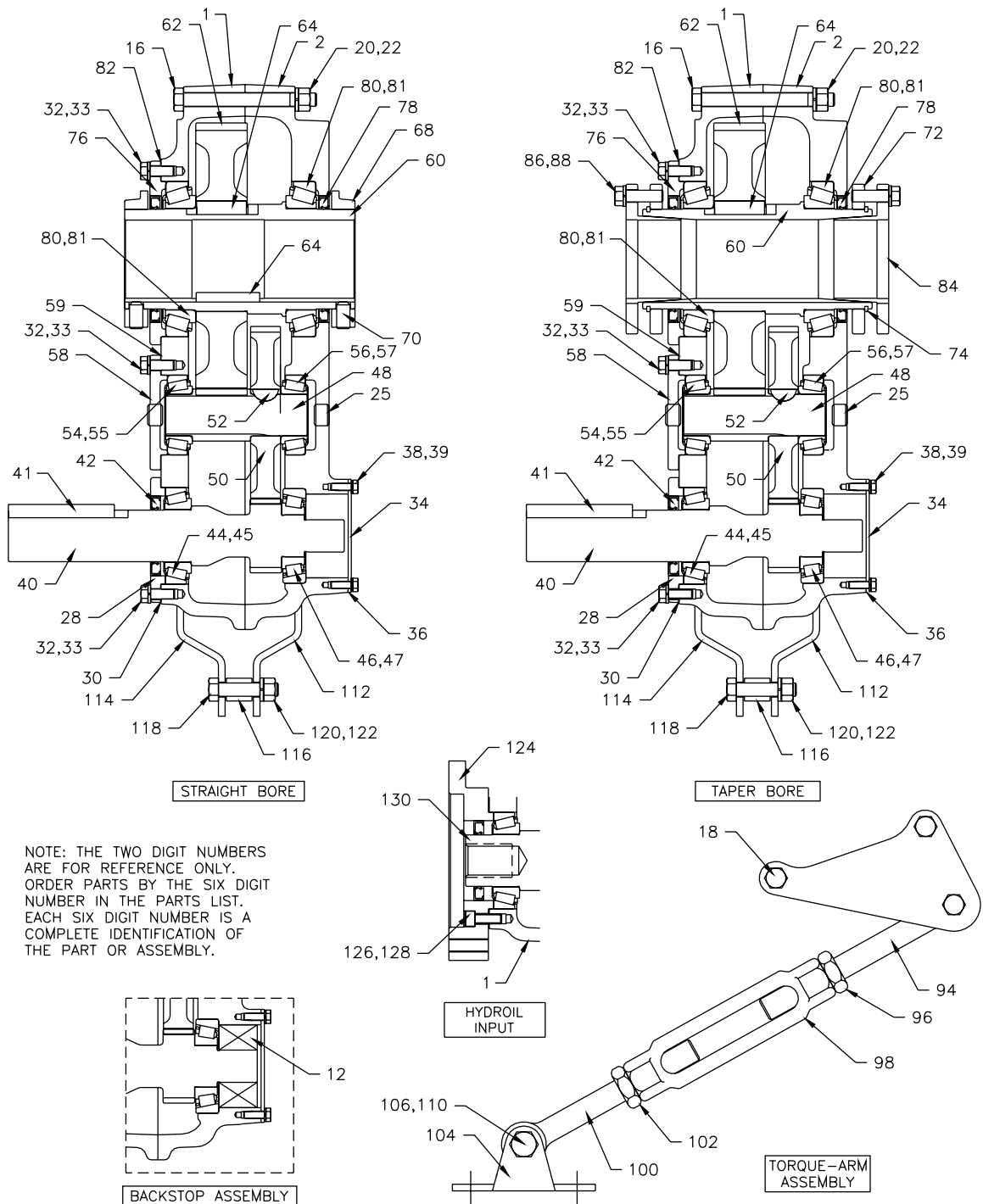

NOTE: THE TWO DIGIT NUMBERS ARE FOR REFERENCE ONLY. ORDER PARTS BY THE SIX DIGIT NUMBER IN THE PARTS LIST. EACH SIX DIGIT NUMBER IS A COMPLETE IDENTIFICATION OF THE PART OR ASSEMBLY.

**Parts for TXT5C thru TXT10A Straight and Tapered Bushed double Reduction Reducers**

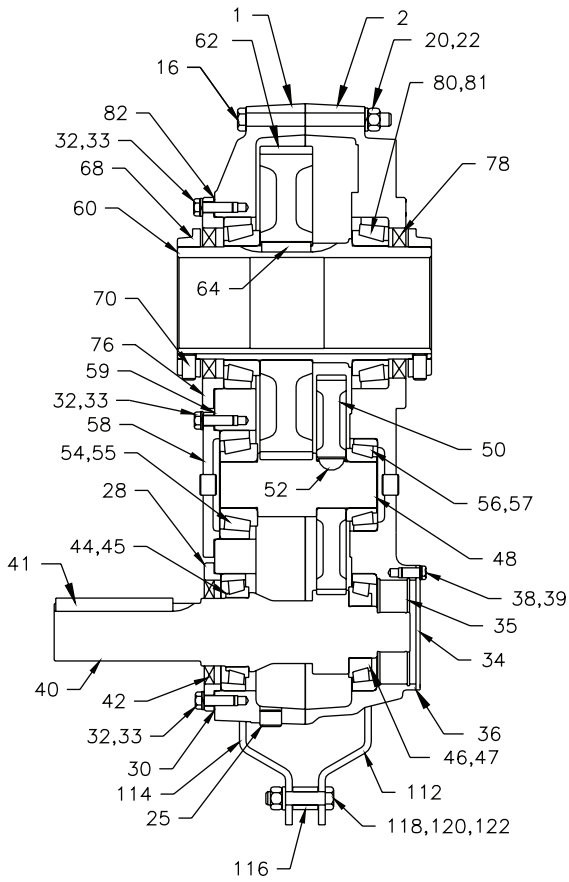

**STRAIGHT BORE**

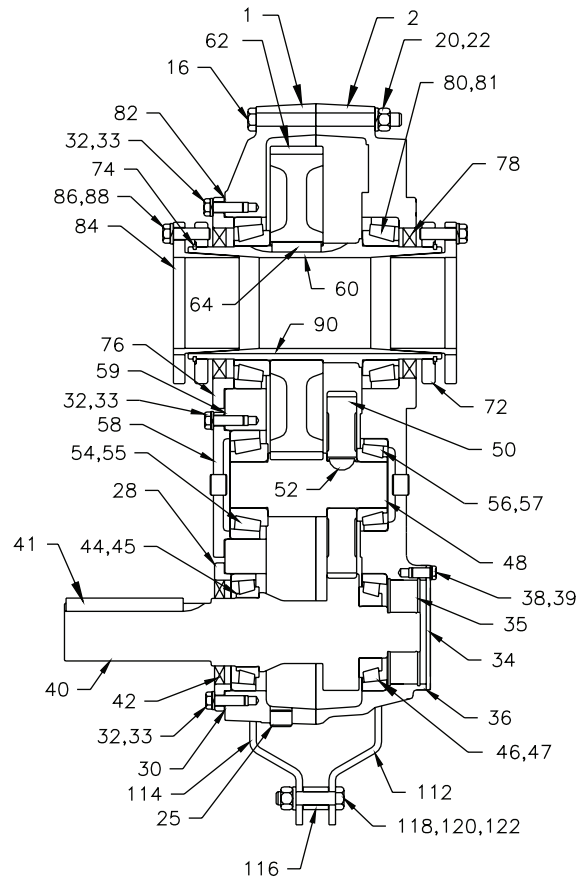

**TAPER BORE**

NOTE: THE TWO DIGIT NUMBERS ARE FOR REFERENCE ONLY. ORDER PARTS BY THE SIX DIGIT NUMBER IN THE PARTS LIST. EACH SIX DIGIT NUMBER IS A COMPLETE IDENTIFICATION OF THE PART OR ASSEMBLY.

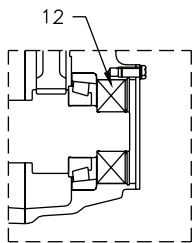

**BACKSTOP ASSEMBLY**

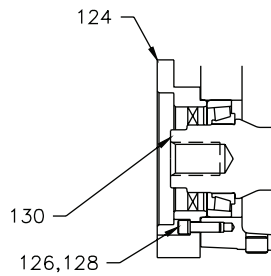

**HYDROIL INPUT**

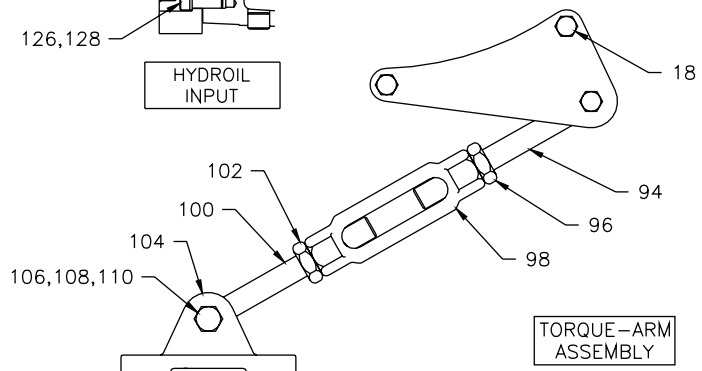

**TORQUE-ARM ASSEMBLY**

**Parts for TXT5C thru TXT10A Straight and Tapered Bushed double Reduction Reducers**

Ref.	Description	Qty.	TXT5C HXT5C	TXT6A HXT6A	TXT7A HXT7A	TXT8A	TXT9A	TXT10A
12	Backstop Assembly	1	245154	246092	247260	249260	249260	250260
1	Housing-TXT and Hydroil LH	1	245369	246358	247358	248358	249358	250358
2	Housing-RH	1	245370	246359	247359	248359	249359	250359
	Housing-RH, Flange Mount Drilled	1						
①	RTV Sealant, Tube	1	245373	465044	465044	465044	465044	465044
①	Air Vent	1	465044	904287	904287	904287	904287	904287
16	Housing Bolt	2	904287	411466	411498	411499	411500	411502
18	Housing Bolt-Adapter	2	411464	411468	411499	411502	411502	411506
20	Lock-Washer	1	411466	419013	419016	419016	419016	419016
22	Hex Nut	4	419013	407091	407095	407095	407095	407095
①	Dowel Pin	2	407091	420147	420148	420148	420148	420148
25	Magnetic Oil Plug	1	420147	430062	430064	430064	430064	430064
①	Oil Plug	4	430062	430033	430035	430035	430035	430035
28	Input Shaft Seal Carrier	1	430033	246184	247320	258023	249211	249211
30	Complete Shim Kit	1	245597	246166	247138	248111	390168	390168
32	Carrier and Cover Screw	⑧	245131	411408	411433	411408	249139	272610
33	Lock Washer	⑧	411407	419011	419012	419011	419011	419011
34	Backstop Cover	1	419011	246226	246226	248226	248226	248226
35	Backstop Retaining Ring	⑦	245226	421029	421029	421034	421034	421034
38	Backstop Cover Screw	6	411394	411394	411394	411394	411394	411394
39	Backstop Cover Lock Washer	6	419009	419009	419009	419009	419009	419009
36	Seal Kit ②	1	389722	246340	247345	248340	249340	272460
	Backstop Cover Gasket ③	1	245220	246220	248220	248220	248220	248220
42	Input Pinion Shaft Seal ③	1	355011	242210	242210	248211	248211	248211
78	Output Hub Oil Seal ③	2	245545	246310	247310	258019	249210	250010
40	Input Pinion							
	9:1 Ratio ⑥	1	245599	246481	247479	N/A	N/A	N/A
	15:1 Ratio ⑥	1	245600	246290	247370	248370	272074	250300
	25:1 Ratio ⑥ ⑨	1	245601	246291	247371	248371	272106	250004
130	15:1 Ratio Hydroil Pinion ⑥	1	245603	246230	247463	N/A	N/A	N/A
	25:1 Ratio Hydroil Pinion ⑥	1	245604	246286	247462	N/A	N/A	N/A
	15:1 Ratio 6B Hydroil Pinion ⑥	1	N/A	N/A	N/A	N/A	N/A	N/A
	25:1 Ratio 6B Hydroil Pinion ⑥	1	245641	246521	247521	N/A	N/A	N/A
41	Input Pinion Shaft Key	1	443096	443113	443127	443133	443123	443123
44	Input Bearings		389594					
	Input Shaft Bearing Cone, Input Side	1	402144	402196	402150	402098	402114	402114
45	Input Shaft Bearing Cup, Input Side	1	403104	403091	403106	403072	403080	403080
46	Input Shaft Bearing Cone, Backstop Side	1	402266	402197	402088	402097	402107	402112
47	Input Shaft Bearing Cup, Backstop Side	1	403073	403091	403047	403072	403076	403080
	Countershaft Pinion Assembly ②							
	9:1 Ratio ⑥	1	389731	392140	392141	N/A	N/A	N/A
	15:1 Ratio ⑥	1	389714	391171	391196	391184	390124	390983
	25:1 Ratio ⑥ ⑩	1	389715	391186	391197	391185	390139	390998
48	Countershaft Pinion ③	1	245596	246294	247002	248002	249006	272249
50	First Reduction Gear ③							
	9:1 Ratio ⑥	1	245482	246482	247478	N/A	N/A	N/A
	15:1 Ratio ⑥	1	245214	246492	247008	248213	249008	250301
	25:1 Ratio ⑥ ⑨	1	245212	246293	247005	248214	249005	250005
52	First Stage Gear Key ③	1	D8243	245218	247218	248218	248218	248218
54	Countershaft Bearings		389595					
	Countershaft Bearing Cone, Input Side	1	402203	402054	402256	402057	402109	402232
55	Countershaft Bearing Cup, Input Side	1	403027	403159	403053	403143	403078	402231
56	Countershaft Bearing Cone, Backstop Side	1	402203	402052	402256	402148	402109	402232
57	Countershaft Bearing Cup, Backstop Side	1	403027	403142	403053	403106	403078	402231
58	Countershaft Bearing Cover, Input Side	1	245594	246185	247194	248223	249225	272251
	Taper Bore Output Hub Assembly ②	1	389717	390935	390941	390944	390949	390954
	Straight Bore Output Hub Assembly ④	1	389716	390988	390990	390993	390159	390160
60	Straight Bore Hub ⑤	1	245591	246338	247338	248332	250090	250008
	Taper Bore Hub ③	1	245590	246269	272137	272036	249140	272241
62	Output Gear ③ ⑤	1	245186	246295	247215	248215	021764	250007
64	Output Gear Key ③ ⑤	2	355064	245217	245217	248217	443413	250017
68	Output Hub Collar, Straight Bore	2	245598	246309	247309	248209	249209	250009
70	Output Hub Collar Screw	4	400154	400154	400190	400190	400194	400194
72	Bushing Backup Plate, Taper Bore	2	245114	246270	272138	272037	272082	272242
74	Output Hub Retaining Ring	2	421107	421055	421099	421098	421097	421069
76	Output Hub Seal Carrier, Input Side	1	245592	246187	247315	258021	249221	250011
80	Output Hub Bearing Kit 1	1	389596					
	Output Hub Bearing, Cone	2	402193	402050	402058	402147	402160	402168
81	Output Hub Bearing, Cup	2	403016	403140	403111	403105	403110	403116

**Parts for TXT6A thru TXT10A Straight and Tapered Bushed double Reduction Reducers**

Ref.	Description	Qty.	TXT5C HXT5C	TXT6A	TXT7A	TXT8A	TXT9A	TXT10A
84	Taper Bore Bushing Assembly ②							
	Bushing ③		N/A					
	2-3/16" Bore	1	N/A	246261	N/A	N/A	N/A	N/A
	2-1/4" Bore	1	N/A	246262	N/A	N/A	N/A	N/A
	2-7/16" Bore	1	N/A	246263	272125	N/A	N/A	N/A
	2-1/2" Bore	1	N/A	246264	N/A	N/A	N/A	N/A
	2-11/16" Bore	1	N/A	246265	272147	N/A	N/A	N/A
	2-13/16" Bore	1	N/A	N/A	272130	N/A	N/A	N/A
	2-7/8" Bore	1	245084	246266	272131	N/A	N/A	N/A
	2-15/16" Bore	1	245086	246267	272132	272048	N/A	N/A
	3" Bore	1	245088	246283	272133	N/A	N/A	N/A
	3-3/16" Bore	1	N/A	N/A	272134	N/A	N/A	N/A
	3-7/16" Bore	1	245090	246268	272135	272032	N/A272056	N/A
	3-15/16" Bore	1	245092	N/A	272136	272033	272077	272214
	4-3/16" Bore	1	245094	N/A	N/A	272034	N/A	N/A
	4-7/16" Bore	1	245099	N/A	N/A	272035	272079	272238
	4-15/16" Bore	1	245110	N/A	N/A	N/A	272080	272239
	5-7/16" Bore	1	245112	N/A	N/A	N/A	N/A	272240
86	Taper Bushing Screw ③	6	411435	411435	411456	411457	411484	411484
88	Taper Bushing Lockwasher ③	6	419012	419012	419013	419013	419014	419014
90	Key, Bushing to Shaft ③	1	N/A	443211	N/A	N/A	N/A	N/A
	2-3/16" Bore	1	N/A	443211	N/A	N/A	N/A	N/A
	2-1/4" Bore	1	N/A	443214	443248	N/A	N/A	N/A
	2-7/16" Bore	1	N/A	443214	N/A	N/A	N/A	N/A
	2-1/2" Bore	1	N/A	443238	443248	N/A	N/A	N/A
	2-11/16" Bore	1	N/A	N/A	443199	N/A	N/A	N/A
	2-13/16" Bore	1	N/A	443236	443199	N/A	N/A	N/A
	2-7/8" Bore	1	443251	443237	443199	N/A	N/A	N/A
	2-15/16" Bore	1	443251	443252	443199	443247	N/A	N/A
	3" Bore	1	443251	N/A	443216	N/A	N/A	N/A
	3-3/16" Bore	1	N/A	443213	443235	N/A	N/A	N/A
	3-7/16" Bore	1	443251	N/A	443217	443171	443249	N/A
	3-15/16" Bore	1	443251	N/A	443218	443173	272119	443192
	4-3/16" Bore	1	443243	N/A	N/A	443174	N/A	N/A
	4-7/16" Bore	1	443244	N/A	N/A	443196	272066	443193
	4-15/16" Bore	1	443245	N/A	N/A	N/A	443161	443194
	5-7/16" Bore	1	443250	N/A	N/A	N/A	N/A	443195
①	Key, Bushing to Output Hub ③							
	2-3/16" thru 2-1/2" Bore Bushing	1	N/A	443212	N/A	N/A	N/A	N/A
	2-7/16" thru 3" Bore Bushing	1	443202	N/A	443198	N/A	N/A	N/A
	2-3/16" thru 2-15/16" Bore Bushing	1	N/A	N/A	N/A	N/A	N/A	N/A
	2-15/16" thru 3-7/16" Bore Bushing	1	N/A	N/A	N/A	443162	N/A	N/A
	3-7/16" thru 4-3/16" Bore Bushing	1	N/A	N/A	N/A	N/A	443121	N/A
	3-15/16" thru 4-7/16" Bore Bushing	1	N/A	N/A	N/A	N/A	N/A	443191
	Torque-Arm Rod Kit ②	1	245097	246097	247098	390129	390129	390129
94	Torque-Arm Rod End ③	1	243245	245245	247239	271050	271050	271050
96	RH Nut ③	1	407095	407097	407099	407104	407104	407104
98	Torque-Arm Turnbuckle ③	1	243246	245246	247246	271051	271051	271051
100	Torque-Arm Extension ③	1	243247	245247	247240	271052	271052	271052
102	LH Nut ③	1	407246	407246	407248	407250	407250	407250
104	Fulcrum ③	1	243249	247248	247248	271054	271054	271054
106	Fulcrum Screw ③	1	411484	411489	411489	411516	411516	411516
108	Lockwasher ③	1	407093	419014	419014	419020	419020	419020
110	Hex Nut ③	1		407093	407093	407099	407099	407099
	Adapter Assembly ②	1	259155	259156	259157	248110	249110	250110
112	RH Adapter Plate ③	1	245242	246242	247242	272053	249241	250041
114	LH Adapter Plate ③	1	245241	246241	247241	272053	249241	250041
116	Adapter Bushing ③	1	245243	245243	247244	271046	271046	211046
118	Adapter Bolt ③	1	411460	411460	411489	411510	411512	411512
120	Lockwasher ③	1	419013	419013	419014	419020	419020	419020
122	Hex Nut ③	1	407091	407091	407093	407099	407099	407099
124	Hydroil Motor Adapter	1		246465	247464	N/A	N/A	N/A
	Hydroil 6B Motor Adapter	1	245606	246522	247522	N/A	N/A	N/A
126	Hydroil Adapter Screw	6	245607	417108	417141	N/A	N/A	N/A
128	Lockwasher	6	245643	906406	907406	N/A	N/A	N/A
①	Motor to Adapter Screw		415023					
①	Motor to Adapter Lock Washer		419047					

**Notes:**

- ① Not shown on drawing
- ② Includes parts listed immediately below
- ③ Makes up assembly under which it is listed
- ④ Includes parts listed immediately below marked
- ⑤ Makes up assembly under which it is listed
- ⑥ See Table 9 for actual ratio
- ⑦ Required only with optional backstop, 1 required on TXT6A and TXT7A, 2 required on TXT8A, TXT9A, & TXT10A.
- ⑧ 18 Required on TXT6A, 20 Required on TXT7A, and 24 Required on TXT8A, TXT9A, & TXT10A
- ⑨ Nominal Ratio on TXT6A, TXT7A, and TXT8A is 25:1, Nominal Ratio on TXT9A is 26:1, and Nominal Ratio on TXT10A is 24:1

—  
**ABB Motors and Mechanical Inc.**

5711 R. S. Boreham Jr. Street  
Fort Smith, AR 72901  
Ph: 1.479.646.4711

Mechanical Power Transmission Support  
Ph: 1.864.297.4800

[new.abb.com/mechanical-power-transmission](http://new.abb.com/mechanical-power-transmission)  
[baldor.com](http://baldor.com)

© ABB Motors and Mechanical Inc.  
MN1610 (Replaces 499304)



All Rights Reserved. Printed in USA.  
02/2019 Litho 25,000