

Installation Manual For Dodge® TORQUE-ARM™ Taconite Auxiliary Seal Kit

TXT1A
TXT2A
TXT3B
TXT4B
TXT5C

TXT6A
TXT8A
TXT9A
TXT10A
TXT105 - TXT905

TXT12
TDT13
TDT14
TDT15

These instructions must be read thoroughly before installing or operating this product.



INSTALLATION:

TXT1A & TXT2A, TXT105 & TXT205

1. Locate, drill, and tap three holes for the input auxiliary seal per the drawing and Table 2.

CAUTION: Do not exceed the specified drill depth listed in the chart. Failure to observe this precaution could result in damage to the equipment.

2. Locate, drill, and tap three holes for the output auxiliary seal per the drawing and Table 2. TXT1A & TXT2A, TXT105 & TXT205 both sides of reducer.
3. Slide rubber V-ring seal onto input shaft so that seal lip faces away from the reducer. Care should be observed while installing the rubber seal to avoid contact with the sharp edges of the input shaft keyseat. To avoid damage to the V-ring, cover the keyseat with tape or paper.

WARNING: Because of the possible danger to person(s) or property from accidents which may result from the improper use of products, it is important that correct procedures be followed. Products must be used in accordance with the engineering information specified in the catalog. Proper installation, maintenance and operation procedures must be observed. The instructions in the instruction manuals must be followed. Inspections should be made as necessary to assure safe operation under prevailing conditions. Proper guards and other suitable safety devices or procedures, as may be desirable, or as may be specified in safety codes should be provided, and are neither provided by Baldor Electric Company, nor are the responsibility of Baldor Electric Company. This unit and its associated equipment must be installed, adjusted and maintained by qualified personnel who are familiar with the construction and operation of all equipment in the system and the potential hazards involved. When risks to persons or property may be involved, a holding device must be an integral part of the driven equipment beyond the speed reducer output shaft.

4. Place the input shaft auxiliary seal housing in place. Install screws and lock washers provided with the kit. Tighten screws alternately and evenly to 96 in.-lbs.
5. Place the LH and RH output hub auxiliary seal housing in position. Install screws and lock washers provided with the kit. Tighten screws alternately and evenly to 96 in.-lbs.

TXT3B through TXT10A, TXT305A through TXT905

1. Remove all bolts from the input seal carrier. Slide rubber V-ring seal onto input shaft so that seal lip faces away from the reducer. Care should be observed while installing the rubber seal to avoid contact with the sharp edges of the input shaft keyseat. To avoid damage to the V-ring, cover the keyseat with tape or paper. Place the auxiliary seal cover on top of the input seal carrier, using the bolts supplied with the kit, secure the auxiliary cover and input seal carrier.
2.
 - a. **TXT3B through TXT6A** - Locate, drill, and tap three holes for the RH only output auxiliary seal per the appropriate Table (see Tables 2 and 3).
 - b. **TXT7A through TXT10A** - Locate, drill, counterbore, and tap four holes for the RH only output auxiliary seal per Table 3.
3. Place the RH auxiliary seal cover in position and secure with bolts supplied with the auxiliary kit.
4. **TXT305A through TXT905** - Remove either three or four screws as required from the RH output seal carrier. Place auxiliary seal cover on top of the carrier and using bolts supplied with the kit, secure auxiliary cover and output seal carrier.
5. **TXT3B through TXT6A, TXT305A through TXT605** - Remove three screws from the LH output seal carrier. Place auxiliary seal cover on top of the carrier and using bolts supplied with the kit, secure auxiliary cover and output seal carrier.
6. **TXT7A through TXT10A, TXT705 through TXT905** - Remove four screws from the LH output seal carrier. Place auxiliary seal cover on top of the carrier and using bolts supplied with the kit, secure auxiliary cover and output seal carrier.

BALDOR • DODGE®

TXT1A through TXT10A, TXT105 through TXT905

1. Remove the standard filter breather plug from the reducer and replace with the ceramic breather plug furnished with the auxiliary seal kit.
2. Mount the reducer on the driven shaft per the instruction manual packaged with the reducer.

WARNING: Insure that all guards are properly installed prior to operating equipment. Exercise extreme care to avoid contacting rotating parts. Failure to observe these precautions could result in bodily injury.

3. Fill seal cavity in both output hub seals and the input shaft seal with a #2 consistency lithium base grease while the reducer is operating. Seal cavities are full when grease shows at the bushing O.D. of the output hub and at the purge hole, opposite the grease fitting, of the input shaft auxiliary seal housing.
4. Re-lubricate as often as necessary to maintain a fresh supply of grease at the seals.

TXT12 through TDT15

1. Remove all bolts from the input shaft seal carrier, but do not remove the seal carrier itself. Slide rubber V-ring seal onto input shaft so that seal lip faces away from reducer. Extreme care should be observed while installing seal to avoid contact with the sharp edges of the keyseat. To avoid any seal damage, cover the keyseat with tape or paper.
2. Place input shaft auxiliary seal housing in position. Note the two lengths of screws provided with the kit. Install the shorter screws thru the auxiliary seal housing and input shaft carrier using the lockwashers removed from the reducer. Tighten screws alternately and evenly to the torque shown in Table 1.
3. Remove every other bolt from one output hub seal carrier. Place one output hub auxiliary seal housing in position, install longer screws provided with the kit using the lockwashers provided from the reducer. Tighten screws alternately and evenly to the torque shown in Table 1.
4. Repeat step 3 for the other output hub auxiliary seal.
5. Remove the breather plug from the reducer and replace it with the filter breather furnished with the kit. This applies to sizes TXT6 thru TXT10 and TXT605 thru TXT905 only.
6. Mount reducer on driven shaft as outlined in the instruction sheet packed with the reducer.
7. Fill seal cavity in both output seals and the input shaft seal with a #2 consistency lithium base grease while the reducer is running. Seal cavities are full when grease shows at the bushing O.D. of the output hub and at the purge hole, opposite the grease fitting, of the input shaft auxiliary seal housing.
8. Relubricate as often as necessary to maintain a fresh supply of grease at the seals.

Table 1 - Torque Values

Bolt Location	Wrench Torque (inch-pounds)			
	TXT12	TDT13	TDT14	TDT15
Input Shaft Auxiliary Seal	1800	1800	3120	3120
Output Hub Auxiliary Seal	3120	3120	5160	5160

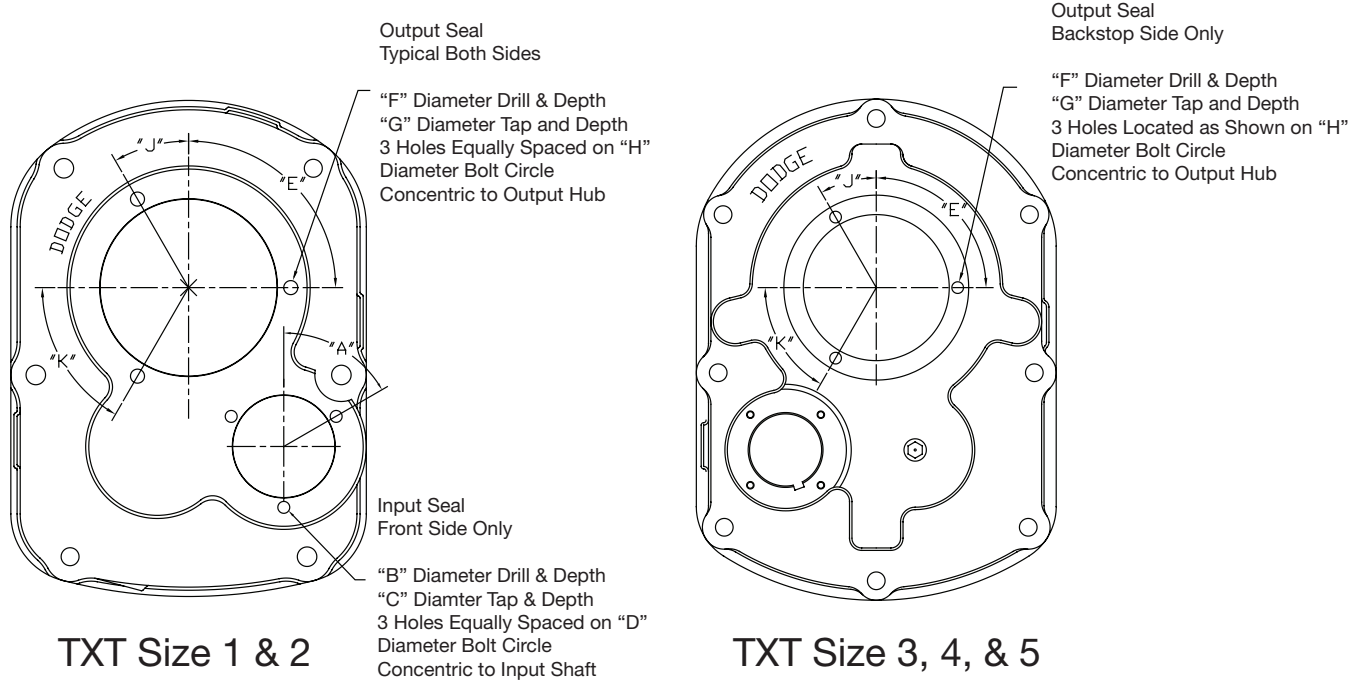

Figure 1 - Machining Dimensions for Installation of Taconite Auxiliary Seal Kits for TXT1A thru TXT5C and TXT105 thru TXT505A

Table 2 - Machining Dimensions for Installation of Taconite Auxiliary Seal Kits for TXT1A thru TXT5C and TXT105 thru TXT505A (Reference Figure 1 for location details)

REDUCER SIZE	“A” (DEGREES)	“B” ^① (INCHES)	“C” (INCHES)	“D” (INCHES)	“E” (DEGREES)	“F” ^① (INCHES)	“G” (INCHES)	“H” (INCHES)	“J” (DEGREES)	“K” (DEGREES)
TXT1A	60°	#7 Ø 3/4 DP	1/4-20 1/2 DP	2-5/8 Ø	120°	#7 Ø 3/4 DP	1/4-20 1/2 DP	4-1/8 Ø	0°	30°
TXT2A	60°	#7 Ø 13/16 DP	1/4-20 9/16 DP	2-15/16 Ø	120°	#7 Ø 7/8 DP	1/4-20 9/16 DP	4-3/4 Ø	0°	30°
TXT3B	N/A	②	②	②	90°	#F Ø 3/4 DP	5/16-18 17/32 DP	5-1/4 Ø	30°	50°
TXT4B	N/A	②	②	②	30°	5/16 Ø 15/16 DP	3/8-16 9/16 DP	6.0 Ø	90°	130°
TXT5C	N/A	②	②	②	90°	5/16 Ø 15/16 DP	3/8-16 9/16 DP	6-5/8 Ø	30°	60°
TXT105	60°	#7 Ø 3/4 DP	1/4-20 1/2 DP	2-15/16	120°	#7 Ø 3/4 DP	1/4-20 1/2 DP	4-1/8 Ø	0°	30°
TXT205	60°	#7 Ø 13/16 DP	1/4-20 9/16 DP	3-11/16	120°	#7 Ø 7/8 DP	1/4-20 5/8 DP	4-3/4 Ø	0°	30°
TXT305A	N/A	②	②	②	90°	#F Ø 3/4 DP	5/16-18 17/32 DP	5-1/4 Ø	30°	50°
TXT405A	N/A	②	②	②	30°	5/16 Ø 15/16 DP	3/8-16 9/16 DP	6.0 Ø	90°	130°
TXT505A	N/A	②	②	②	90°	5/16 Ø 15/16 DP	3/8-16 9/16 DP	6-5/8 Ø	30°	60°

① Drill depth is maximum and must not be exceeded.

② Place auxiliary seal cover on input seal carrier using bolts provided.

TXT 6A Only
Output Seal Installation
Backstop Side Only

TXT 7A Thru 10A Only
Output Seal Installation
Backstop Side Only

"B" Diameter, Drill and Depth
"C" Diameter Tap and Depth
3 Holes Equally Spaced on "E" Diameter
Bolt Circle Concentric to Output Hub

"B" Diameter, Drill and Depth
"C" Diameter Tap and Depth
4 Holes Equally Spaced on "E" Diameter
Bolt Circle Concentric to Output Hub

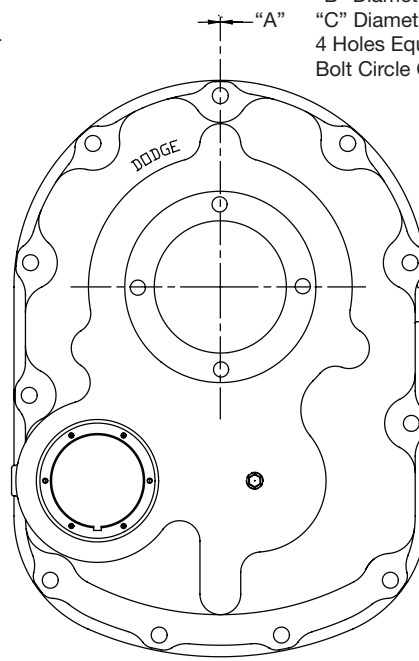
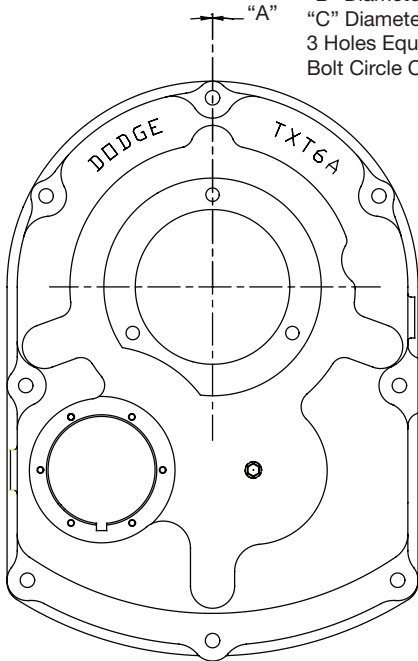

TXT Size 6A
Backstop Side Only

TXT Size 7A Thru 10A
Backstop Side Only

Figure 2 - Machining Dimensions for Installation of Taconite Auxiliary Seal Kits
TXT6A thru TXT10A

Table 3 - Machining Dimensions for Installation of Taconite Auxiliary Seal Kits TXT6A thru TXT10A
(Reference Figure 2 for location details)

REDUCER SIZE	"A" (DEGREES)	"B" ① (INCHES)	"C" (INCHES)	"D" (INCHES)	"E" (INCHES)
TXT6A	0°	5/16 Ø 1-3/8 DP	3/8-16 1-1/16 DP	7/16 Ø 3/8 DP	7-1/4 Ø
TXT7A	0°	23/64 Ø 1-11/16 DP	7/16-14 1-5/16 DP	1/2 Ø 3/8 DP	8-1/8 Ø
TXT8A	0°	5/16 Ø 1-11/16 DP	3/8-16 1-3/8 DP	7/16 Ø 3/8 DP	8-5/8 Ø
TXT9A	0°	5/16 Ø 1-5/8 DP	3/8-16 1-5/16 DP	7/16 Ø 3/8 DP	9-15/16 Ø
TXT10A	0°	5/16 Ø 1-5/8 DP	3/8-16 1-5/16 DP	7/16 Ø 3/8 DP	11.0 Ø

① DRILL DEPTH IS MAXIMUM AND MUST NOT BE EXCEEDED.

BALDOR
A MEMBER OF THE ABB GROUP

P.O. Box 2400, Fort Smith, AR 72902-2400 U.S.A., Ph: (1) 479.646.4711, Fax (1) 479.648.5792, International Fax (1) 479.648.5895

Dodge Product Support

6040 Ponders Court, Greenville, SC 29615-4617 U.S.A., Ph: (1) 864.297.4800, Fax: (1) 864.281.2433

www.baldor.com

© Baldor Electric Company
MN1605 (Replaces 499346
and MN1625)



All Rights Reserved. Printed in USA.
06/14 Printshop 100