

# Tigear-2 Stainless Steel Torque Arm Installation Instruction

These instructions must be read thoroughly before installation or operation. This instruction manual was accurate at the time of printing. Please see [www.baldor.com](http://www.baldor.com) for updated instruction manuals.

**WARNING:** To ensure the drive is not unexpectedly started, turn off and lock-out or tag power source before proceeding. Failure to observe these precautions could result in bodily injury.

**WARNING:** All products over 25 kg (55 lbs) are noted on the shipping package. Proper lifting practices are required for these products.

**WARNING:** Follow appropriate lock-out / tag-out procedures to immobilize the drive motor and driven equipment.

**WARNING:** Only qualified, trained, maintenance personnel should install the torque arm and reducer onto the driven equipment.

**WARNING:** Provide a proper support for the reducer while mounting it on the driven shaft.

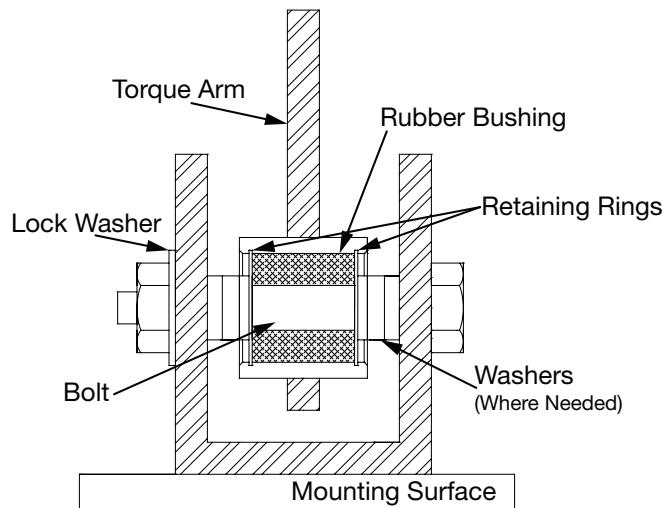

**Figure 1 - Tigear-2 Stainless Steel Torque Arm Mounted to Customer Bracket**

**WARNING:** Because of the possible danger to person(s) or property from accidents which may result from the improper use of products, it is important that correct procedures be followed. Products must be used in accordance with the engineering information specified in the catalog. Proper installation, maintenance and operation procedures must be observed. The instructions in the instruction manuals must be followed. Inspections should be made as necessary to assure safe operation under prevailing conditions. Proper guards and other suitable safety devices or procedures, as may be desirable, or as may be specified in safety codes should be provided, and are neither provided by Baldor Electric, nor are the responsibility of Baldor Electric. This unit and its associated equipment must be installed, adjusted and maintained by qualified personnel who are familiar with the construction and operation of all equipment in the system and the potential hazards involved. When risks to persons or property may be involved, a holding device must be an integral part of the driven equipment beyond the speed reducer output shaft.

## Installation:

1. Ensure the torque arm bracket and the mounting surface is rigid and does not deflect or vibrate under load.
2. Mount the torque arm to the reducer using the supplied bolts and flat washers. There are two bolt lengths supplied in the kit. The longer bolts are used on the bearing housing side (left side). Remove the existing bearing housing bolts and replace them with the longer supplied bolts. The short bolts are used to attach the torque arm to the reducer side opposite the bearing housing (right side). Remove the existing bolts and replace with the short supplied bolts. Apply removable thread locker and tighten the bolts to the specified torque values in Table 1. Acceptable torque arm mounting positions are shown in Figure 2.
3. The mounting bolt in the torque arm bracket should be securely fixed with a second nut or lock washer to prevent it from loosening when the rubber bushing compresses. Ensure the bolt is centered in the torque arm bracket.
4. Use washers to prevent the bracket from touching the torque arm. Use washers in between the bracket and torque arm to ensure clearance and a snug fit.
5. Position the torque arm to align with the bracket and washers. Insert the bolt and secure with a nut or washer. Do NOT force the torque arm. If it does not align properly in the bracket, realign the bracket.

## Bushing Replacement

1. To replace the bushing, first remove the retaining rings on both sides of the bushing.
2. Press the bushing out of the torque arm. The bushing is press fit in the torque arm when first installed.
3. Re-install one of the retaining rings. Then press the new bushing up to the retaining ring.
4. Re-install the other retaining ring.

**NOTE:** The only recommended bracket should be a U-shaped bracket shown in Figure 1 to hold both sides.

Table 1 - Torque Values

Tigear-2 Stainless Steel Torque Arm			
Unit Size	Bolt - 304 Stainless Steel	Tightening Torque (Nm)	Tightening Torque (ft-lb)
17	5/16 - 18	14	10
20	5/16 - 18	14	10
23	3/8 - 16	24	18
26	3/8 - 16	24	18
30	7/16 - 14	39	29

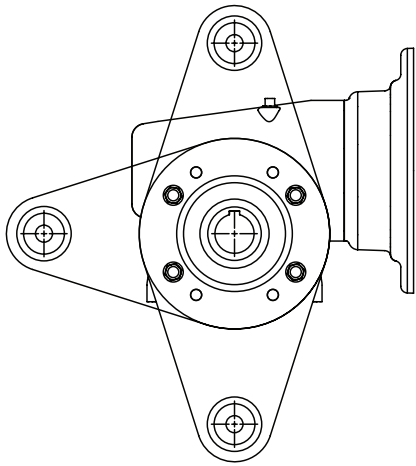

**Figure 2 - Stainless Steel Torque-Arm  
Possible Mounting Positions**

### Dimensions

#### Stainless Steel Torque Arm Kit

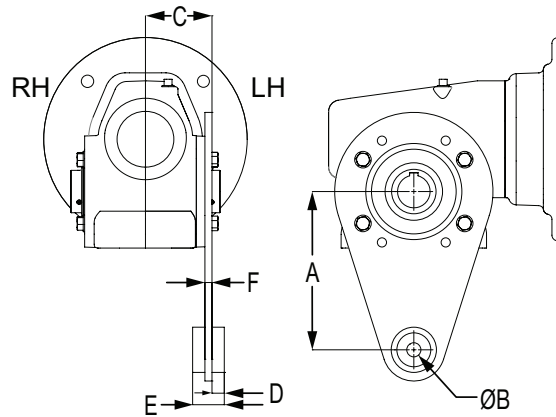

Tigear-2 Case Size	Torque Arm							
	Part Number	A	ØB	C		D	E	F
				RH	LH			
17	SS17TORQARM	6.00	0.50	2.57	2.58	0.43	1.10	0.25
20	SS20TORQARM	6.00	0.50	2.57	2.55	0.43	1.10	0.25
23	SS23TORQARM	7.00	0.63	3.00	2.94	0.54	1.40	0.31
26	SS26TORQARM	7.00	0.63	2.94	2.94	0.54	1.40	0.31
30	SS30TORQARM	10.00	0.63	3.50	3.50	0.51	1.40	0.38

**BALDOR**  
A MEMBER OF THE ABB GROUP

P.O. Box 2400, Fort Smith, AR 72902-2400 U.S.A., Ph: (1) 479.646.4711, Fax (1) 479.648.5792, International Fax (1) 479.648.5895

**Dodge Product Support**

6040 Ponders Court, Greenville, SC 29615-4617 U.S.A., Ph: (1) 864.297.4800, Fax: (1) 864.281.2433

[www.baldor.com](http://www.baldor.com)

