

Installation and Parts Replacement Manual for Dodge® Torque-Arm™ TXT/HTX Single Reduction Taper Bushed and Straight Bore Speed Reducers TXT/HXT 105 TXT/HXT 205

These instructions must be read thoroughly before installation or operation. This instruction manual was accurate at the time of printing. Please see baldor.com for updated instruction manuals.

Note! The manufacturer of these products, Baldor Electric Company, became ABB Motors and Mechanical Inc. on March 1, 2018. Nameplates, Declaration of Conformity and other collateral material may contain the company name of Baldor Electric Company and the brand names of Baldor-Dodge and Baldor-Reliance until such time as all materials have been updated to reflect our new corporate identity.

WARNING: To ensure the drive is not unexpectedly started, turn off and lock-out or tag power source before proceeding. Failure to observe these precautions could result in bodily injury.

WARNING: All products over 25 kg (55 lbs) are noted on the shipping package. Proper lifting practices are required for these products.

Installation Instructions

NOTE: This reducer is compatible with the ABB Ability Smart Sensor, that can be installed in the adapter plug labeled “smart sensor”. The plug and sensor can be moved to different locations as required by mounting position.

1. Use lifting bracket where applicable to lift reducer.
2. Determine the running positions of the reducer. (See Fig. 1). Note that the reducer is supplied with six plugs; four around the sides for horizontal installations and one on each face for vertical installations. These plugs must be arranged relative to the running positions as follows:

WARNING: Because of the possible danger to person(s) or property from accidents which may result from the improper use of products, it is important that correct procedures be followed. Products must be used in accordance with the engineering information specified in the catalog. Proper installation, maintenance and operation procedures must be observed. The instructions in the instruction manuals must be followed. Inspections should be made as necessary to assure safe operation under prevailing conditions. Proper guards and other suitable safety devices or procedures as may be desirable or as may be specified in safety codes should be provided, and are neither provided by ABB nor are the responsibility of ABB. This unit and its associated equipment must be installed, adjusted and maintained by qualified personnel who are familiar with the construction and operation of all equipment in the system and the potential hazards involved. When risk to persons or property may be involved, a holding device must be an integral part of the driven equipment beyond the speed reducer output shaft.

Horizontal Installations - Install the magnetic drain plug in the hole closest to the bottom of the reducer. Install the filter/ventilation plug in topmost hole. Of the two remaining plugs on the sides of the reducer, the lowest plug is the minimum oil level plug.

Vertical Installations - Install the filter/ventilation plug in the hole provided in the upper face of the reducer housing. If space is restricted on the upper face, install the vent in the highest hole on the side of the reducer per Figure 1 using the optional vertical vent kit. Install a plug in the hole in the bottom face of the reducer. Do not use this hole for the magnetic drain plug. Install the magnetic drain plug in the lowest hole on the sides of the reducer. Of the remaining holes on the sides of the reducer, use the plug in the upper housing half for the minimum oil level plug.

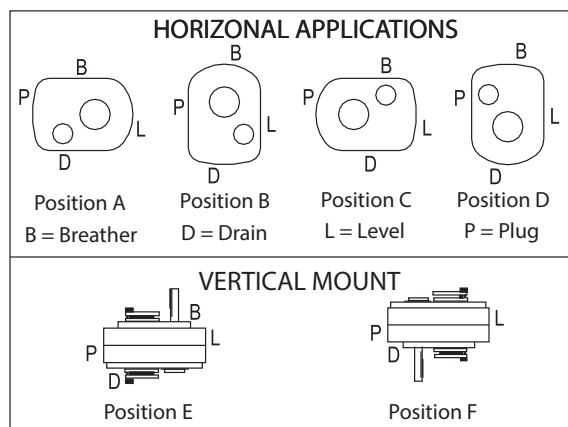

Below 15 RPM output speed, oil level must be adjusted to reach the highest oil level plug. If reducer position is to vary from those shown in Figure 1, either more or less oil may be required. Consult Dodge Product Support.

The running position of the reducer in a horizontal application is not limited to the four positions shown in Fig. 1. However, if running position is over 20° in position “B” & “D” or 5° in position “A” & “C”, either way from sketches, the oil level plug cannot be used safely to check the oil level, unless during the checking, the torque arm is disconnected and the reducer is swung to within 20° for position “A” & “C” or 5° for position “B” & “D” of the positions shown in Fig. 1. Because of the many possible positions of the reducer, it may be necessary or desirable to make special adaptations using the lubrication filling holes furnished along with other standard pipe fittings, stand pipes and oil level gauges as required.

3. Mount reducer on driven shaft as follows:

For Taper Bushed Reducer: Mount the reducer on the driven shaft per instructions for the tapered bushing kit.

4. Install sheave on input shaft as close to reducer as practical. (See Fig. 2)
5. If not using a Dodge Torque-Arm motor mount, install motor and V-belt drive so belt will approximately be at right angles to the centerline between driven and input shaft. (See Fig. 3) This will permit tightening the V-belt with the torque arm.
6. Install torque arm and adapter plates using the long reducer bolts. The adapter plates may be installed in any position around the input end of the reducer.
7. Install torque arm fulcrum on a flat and rigid support so that the torque arm will be approximately at right angles to the centerline through the driven shaft and the torque arm anchor screw. (See Fig. 4) Make sure that there is sufficient take-up in the turnbuckle for belt tension adjustment when using V-belt drive.

CAUTION: Unit is shipped without oil. Add proper amount of recommended lubricant before operating. Failure to observe this precaution could result in damage to or destruction of the equipment.

8. Fill gear reducer with the recommended volume of lubricant per table 2.

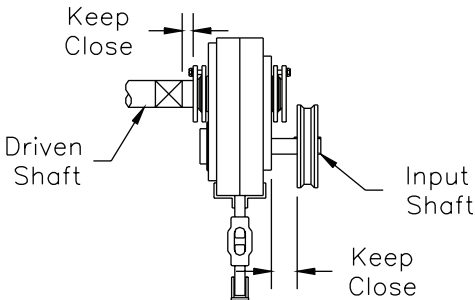

Figure 2 - Reducer and Sheave Installation

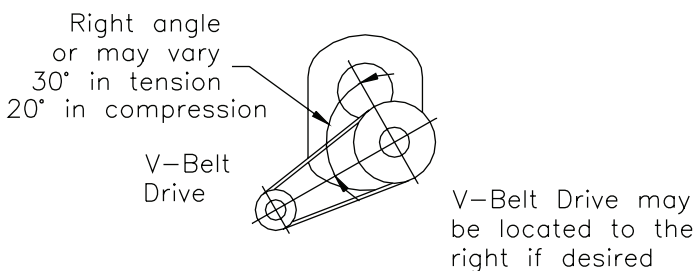

Figure 3 - Angle of V-Drive

TXT TAPERED BUSHING INSTALLATION

1. One bushing assembly is required to mount the reducer on the driven shaft. An assembly consists of two tapered bushings, bushing screws and washers, and necessary shaft keys or key.

The driven shaft must extend through the full length of the reducer. The minimum shaft length, as measured from the end of the shaft to the outer edge of the bushing flange (see Figure 5), is given in Table 1. This dimension does not include dimension "A". Dimension "A" should be added to the minimum shaft length to allow for the removal of the bushings at disassembly.

2. Place one bushing, flange end first, onto the driven shaft and position per dimension "A", as shown in Table 1. This will allow the bolts to be threaded into the bushing and for future bushing and reducer removal. If the reducer must be positioned closer to the equipment than dimension "A", place the screws, with washers installed, into the unthreaded holes of the bushing flange prior to placing the bushing on the shaft and position as required.
3. Insert the output key in the shaft and bushing. For easy of installation, rotate the driven shaft so that the shaft keyseat is at the top position.
4. Mount the reducer on the driven shaft and align the shaft key with the reducer hub keyway. Maintain the recommended minimum distance "A" from the shaft bearing.
5. Insert the screws, with washers installed, in the unthreaded holes in the bushing flange and align with the threaded holes in the bushing backup plate. If necessary, rotate the bushing backup plate to align with the bushing screws. Tighten the screws lightly. If the reducer must be positioned closer than dimension "A", place the screws with washers installed, in the unthreaded holes in the bushing before positioning reducer making sure to maintain at least 1/8" between the screw heads and the bearing.
6. Place the second tapered bushing in position on the shaft and align the bushing keyway with the shaft key. Align the unthreaded holes in the bushing with the threaded holes in the bushing backup plate. If necessary, rotate the bushing backup plate to align with the bushing holes. Insert bushing screws, with washers installed in the unthreaded holes in the bushing. Tighten screws lightly.
7. Alternately and evenly tighten the screws in the bushing nearest the equipment to the recommended torque given in Table 1. Repeat procedure on outer bushing.

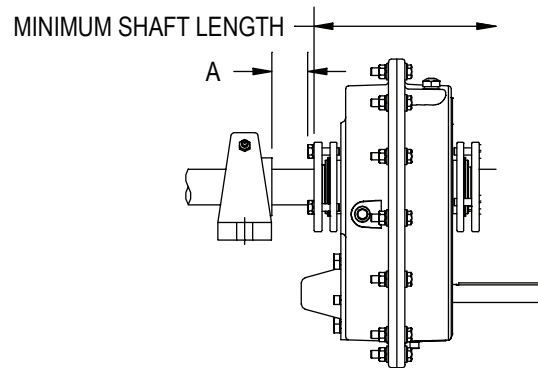

Figure 5 - Minimum Recommended Dimensions

Table 1 - Minimum Mounting Dimensions and Bolt Torques		
Minimum Required Shaft Length		
Reducer Size	Taper Bushing	Straight Bushing
TXT/HXT 105	6-1/2	5-5/8
TXT/HXT 205	6-3/4	5-13/16

Bushing Screw Information and Minimum Clearance for Removal			
Reducer Size	Fastener Size	Torque in In.-Lbs.	Dim. "A"
TXT/HXT 105	5/16-18	200	1-1/4
TXT/HXT 205	5/16-18	200	1-1/4

Straight Bore Bushings:

- One bushing assembly is required to mount the reducer on the driven shaft. An assembly consists of one keyed straight bushing, one plain straight bushing, required set screws, and necessary shaft key or keys.

The driven shaft must extend through the reducer to operate properly. The minimum shaft length, as measured from the end of the shaft to the outer edge of the retaining collar, is given in Table 1.

- Install the plain bushing into the reducer output hub on the side toward the equipment or bearing. Remove two short set screws from the retaining collar and install two of the longer set screws supplied with the bushing kit. Line up the bushing holes with the set screws. Thread the set screws in until they locate into the bushing holes. Make sure the set screws are threaded in only enough to locate the bushing in the reducer hub and does not extend through the bushing.
- Install the keyed bushing into the opposite end of the reducer hub as the plain bushing. Remove one short set screw from the retaining collar and install the remaining set screw from the bushing kit into the collar. Line up the bushing hole with the set screw. Thread the set screw in until it locates into the bushing hole. Make sure the set screw is threaded in only enough to locate the bushing in the reducer hub and does not extend through the bushing.
- Mount the reducer on the driven shaft as close to the equipment or bearing as practical.
- Line up the keyway in the bushing with the keyway in the driven shaft. Insert the key supplied with the bushing kit into the keyway. Gently tap the key into position until the key is flush with the edge of the reducer. Securely tighten all set screws.

Standard Tapered Bushings Removal:

- Remove bushing screws.
- Place the screws in the threaded holes provided in the bushing flanges. Tighten the screws alternately and evenly until the bushings are free on the shaft. For ease of tightening screws make sure screw threads and threaded holes in the bushing flanges are clean. If the reducer was positioned closer than the recommended minimum distance "A" as shown in Table 1, loosen the inboard bushing screws until they are clear of the bushing flange by 1/8". Locate two (2) wedges at 180 degrees between the bushing flange and the bushing backup plate. Drive the wedges alternately and evenly until the bushing is free on the shaft.
- Remove the outside bushing, the reducer, key(s), and inboard bushing.

LUBRICATION

NOTE: Because Torque-Arm reducers are shipped without oil, it is extremely important to add the proper amount of lubricant prior to operating reducer. For most applications a high-grade petroleum-base rust and oxidation inhibited (R&O) gear oil is suitable. See Table 2 and Table 3 for proper oil volume and viscosity requirements.

Under severe conditions EP oil can be used provided the reducer is not equipped with an internal backstop. Internal backstops are designed to rely on friction to operate correctly. EP lubricants contain friction modifiers that will alter backstop performance and therefore must not be used on reducers equipped with internal backstops.

Follow instructions on reducer warning tags.

Lubrication is very important for satisfactory operation. The proper oil level must be maintained at all times. Frequent inspection, at least monthly, with the unit not running and allowing sufficient time for the oil to cool and the entrapped air to settle out of the oil should be made by removing the level plug and verifying the level is being maintained. If oil level is low, add the proper lubricant until the oil volume is increased to the correct level.

After an initial operation of about two weeks, the oil should be changed. If desired, this oil may be filtered and reused. After the initial break in period, under average industrial operating conditions, the lubricant should be changed every 2500 hours of operation. At every oil change, drain reducer and flush with kerosene, clean magnetic drain plug and refill to proper level with new lubricant.

Under extreme operating conditions, such as rapid rise and fall of temperature, dust, dirt, chemical particles, chemical fumes, or oil sump temperatures above 200°F, the oil should be changed every 1 to 3 months, depending on severity of conditions.

CAUTION: Too much oil will cause overheating and too little will result in gear failure. Check oil level regularly. Failure to observe this precaution could result in equipment damage and/or bodily injury.

CAUTION: Extreme pressure (EP) lubricants are not recommended for average operating conditions. Do not use extreme pressure lubricants containing slippery additives such as graphite or molybdenum disulfide in reducers with internal backstops. Failure to observe these precautions could result in bodily injury.

Reducer		Approximate Volume of Oil to Fill Reducer to Oil Level Plug ① ⑤ ⑥											
		② Position A		② Position B		② Position C		② Position D		② Position E		② Position F	
Size	Ratio	③ Qt	④ L	③ Qt	④ L	③ Qt	④ L	③ Qt	④ L	③ Qt	④ L	③ Qt	④ L
TXT/HXT 105	5	.63	.59	.75	.71	.63	.59	.75	.71	1.13	1.06	1.38	1.30
TXT/HXT 205	5	.75	.71	.88	.83	.88	.83	.88	.83	1.75	1.66	2.25	2.13

① Oil quantity is approximate. Service with lubricant until oil runs out of oil level hole.

② Refer to Figure 1 for mounting positions.

③ US measure: 1 quart = 32 fluid ounces = .94646 liters.

④ Conversion from quarts rounded values.

⑤ Below 15 RPM output speed, oil level must be adjusted to reach the highest oil level plug. If reducer position is to vary from those shown in Figure 1, either more or less oil may be required. Consult Dodge Product Support.

⑥ Consult Dodge Product Support for proper oil level for reducers equipped with backstops and which are mounted in either the C position or D position.

Heating is a natural characteristic of enclosed gearing. A maximum gear case temperature approaching 200°F is not uncommon for some units operating in normal ambient temperatures of 80°F. When operating at the rated capacity with proper lubrication, no damage will result from this temperature. This maximum temperature was taken into consideration during the design of the reducer.

Table 3 - Oil Recommendations		
ISO Grades for Ambient Temperatures of 50°F to 125°F		
Output RPM	Torque-Arm Reducer Size	
	TXT/HXT 105	TXT/HXT 205
301 – 400	320	320
201 – 300	320	320
151 – 200	320	320
126 – 150	320	320
101 – 125	320	320
81 – 100	320	320
41 – 80	320	320
11 – 40	320	320
1 – 10	320	320
ISO Grades For Ambient Temperatures of 15°F to 60°F		
Output RPM	Torque-Arm Reducer Size	
	TXT/HXT 105	TXT/HXT 205
301 – 400	220	220
201 – 300	220	220
151 – 200	220	220

Table 3 - Oil Recommendations		
126 – 150	220	220
101 – 125	220	220
81 – 100	220	220
41 – 80	220	220
11 – 40	220	220
1 – 10	220	220

Notes:

1. Assumes auxiliary cooling where recommended in the catalog.
2. Pour point of lubricant selected should be at least 10°F lower than expected minimum ambient starting temperature.
3. Extreme pressure (EP) lubricants are not necessary for average operating conditions. TORQUE-ARM internal backstops are not suitable for use with EP lubricants.
4. Special lubricants may be required for food and drug industry applications where contact with the product being manufactured may occur. Consult a lubrication manufacturer's representative for his recommendations.
5. For reducers operating in ambient temperatures between -22°F (-30°C) and 20°F (-6.6°C) use a synthetic hydrocarbon lubricant, 100 ISO grade or AGMA 3 grade (for example, Mobil SHC627). Above 125°F (51°C), consult DODGE Gear Application Engineering (864) 288-9050 for lubrication recommendation.
6. Mobil SHC630 Series oil is recommended for high ambient temperatures.

OIL VISCOSITY EQUIVALENCY CHART

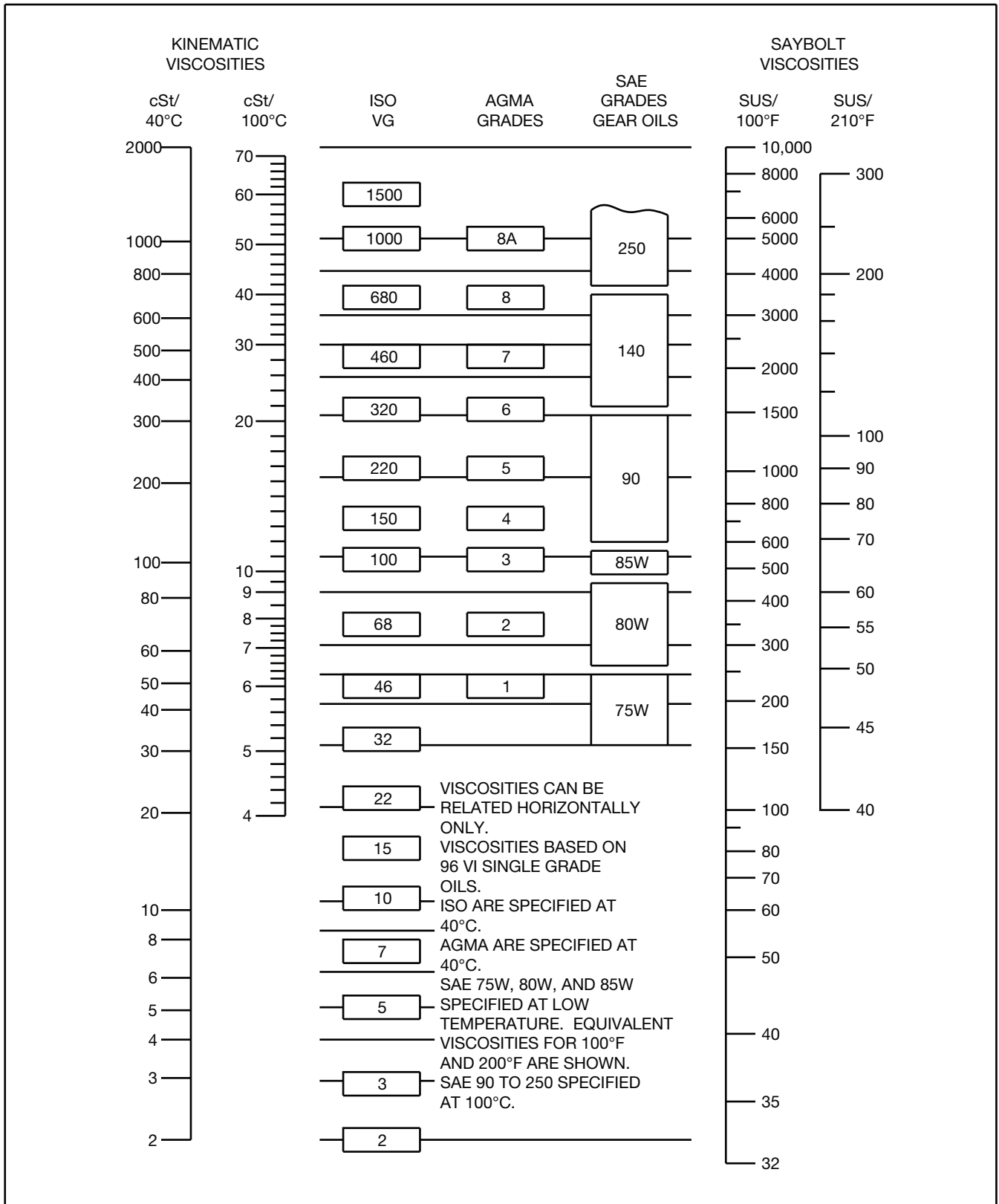

VANE MOTOR INSTALLATION

Mounting:

Hydroil Vane motors are designed to operate in any position. The position with respect to the Hydroil Reducer may be changed by rotating the adapter on the reducer. The mounting adapter into which the motor pilots must be concentric with the motor and driven shaft to prevent bearing failures. The concentricity is particularly important if the motor shaft is rigidly connected to the driven load without an intermediate flexible coupling.

Piping:

Flexible hose must be used (not rigid piping) to prevent strains on motor housing which could result from external alignment problems.

Three hoses are required: two larger diameter high pressure supply and return hoses which are connected to the high pressure motor ports (A & B) and a smaller diameter low pressure housing drain hose. The supply and return hoses should be of adequate size and strength to assure proper motor operation and withstand the high operating pressures. The drain line must be connected directly to the reservoir tank with hose capable of withstanding pressures of up to 50 psi. For best results, the drain should be extended below the oil level.

All hoses should be thoroughly cleaned with solvent before the motor is connected. Be sure that the entire hydraulic system is free from dirt, lint, scale or other foreign matter. Oil filters should be used to insure a clean hydraulic system. Filters should be used at the reservoir breather and the oil filler openings.

Because the porting is symmetrical, the motor can be reversed by reversing oil flow to the ports. Flow into port A will result in clockwise rotation as viewed from the shaft end of the motor. Flow into port B will result in counterclockwise rotation.

CAUTION: For applications where reverse rotation could cause damage, check HYDROIL motor rotation before connecting motor to driven shaft.

Oil:

The efficient operation of the entire hydraulic system depends largely on the ability of the oil to convey the power generated by the pump and lubricate the moving parts within the system. Therefore, the importance of selecting a high-grade hydraulic oil from a reputable manufacturer cannot be over emphasized. High-grade mineral base oils with anti-wear additives and rust and oxidation inhibitors are recommended. The viscosity required at starting and operating temperature is listed in the following table. Never use multi-grade oils.

Motor Size	Viscosity Range SUS 100°F	Viscosity Index	Maximum Viscosity at Starting Temp.	Maximum Allowable Motor Pressure
B30	150-330	90 or above	7500 SUS	2500 PSI

GUIDELINES FOR TXT REDUCER LONG-TERM STORAGE

During periods of long storage, or when waiting for delivery or installation of other equipment, special care should be taken to protect a gear reducer to have it ready to be in the best condition when placed into service.

By taking special precautions, problems such as seal leakage and reducer failure due to lack of lubrication, improper lubrication quantity, or contamination can be avoided. The following precautions will protect gear reducers during periods of extended storage:

Preparation:

1. Drain oil from the unit. Add a vapor phase corrosion inhibiting oil (VCI-105 oil by Daubert Chemical Co.) in accordance with Table 4.
2. Seal the unit airtight. Replace the vent plug with a standard pipe plug and wire the vent to the unit.
3. Cover all unpainted exterior parts with a waxy rust preventative compound that will keep oxygen away from the bare metal. (Non-Rust X-110 by Daubert Chemical Co. or equivalent)
4. The instruction manuals and lubrication tags are paper and must be kept dry. Either remove these documents and store them inside, or cover the unit with a durable waterproof cover which can keep moisture away.
5. Protect reducer from dust, moisture, and other contaminants by storing the unit in a dry area.
6. In damp environments, the reducer should be packed inside a moisture-proof container or an envelope of polyethylene containing a desiccant material. If the reducer is to be stored outdoors, cover the entire exterior with a rust preventative.

When placing the reducer into service:

1. Fill the unit to the proper oil level using a recommended lubricant. The VCI oil will not affect the new lubricant.
2. Clean the shaft extensions with petroleum solvents.
3. Assemble the vent plug into the proper hole.

Follow the installation instructions provided in this manual.

Reducer Size	Quantity (Ounces / Milliliter)
TXT/HXT 105	1/30
TXT/HXT 205	1/30

VCI #105 and #10 are interchangeable.
VCI #105 is more readily available.

REPLACEMENT OF PARTS

IMPORTANT: Using tools normally found in a maintenance department, a Dodge Torque-Arm speed reducer can be disassembled and reassembled by careful attention to the instructions following.

Cleanliness is very important to prevent the introduction of dirt into the bearings and other parts of the reducer. A tank of clean solvent, an arbor press, and equipment for heating bearings and gears (for shrinking these parts on shafts) should be available.

Our factory is prepared to repair reducers for customers who do not have proper facilities or who, for any reason, desire factory service.

The oil seals are designed with a contact lip. Considerable care should be used during disassembly and reassembly to avoid damage to the surface on which the seals rub.

The keyseat in the input shaft, as well as any sharp edges on the output hub should be covered with tape or paper before disassembly or reassembly. Also, be careful to remove any burrs or nicks on surfaces of the input shaft or output hub before disassembly or reassembly.

Ordering Parts: When ordering parts for a Dodge Torque Arm reducer, specify reducer part number, part name, and quantity required.

It is strongly recommended that, when a pinion or gear is replaced, the mating pinion or gear is replaced also.

If the large gear on the output hub must be replaced, it is recommended that an output hub assembly consisting of a gear assembled on a hub be ordered to ensure undamaged surfaces on the output hub where the output seals rub. However, if it is desired to use the old output hub, press the gear and bearing off and examine the rubbing surface under the oil seal carefully for possible scratching or other damage resulting from the pressing operation. To prevent oil leakage at the shaft oil seals, the smooth surface of the output hub must not be damaged.

If any parts must be pressed from a shaft or from the output hub, this should be done before ordering parts to make sure that none of the bearings or other parts are damaged in removal. Do not press against rollers or cage of any bearing.

Because old shaft oil seals may be damaged in disassembly, it is advisable to order replacements for these parts.

Removing Reducer from Shaft:

Taper Bushed Reducer:

1. Disconnect and remove belt guard, v-drive, and motor mount as required. Disconnect torque arm rod from reducer adapter.
2. Remove bushing screws.
3. Place the screws in the threaded holes provided in the bushing flanges. Tighten the screws alternately and evenly until the bushings are free on the shaft. For ease of tightening screws, make sure screw threads and threaded holes in bushing flanges are clean. A tap can be used to clean out the threads. Use caution to use the proper size tap to prevent damage to the threads.
4. Remove the outside bushing, the reducer, and then the inboard bushing.

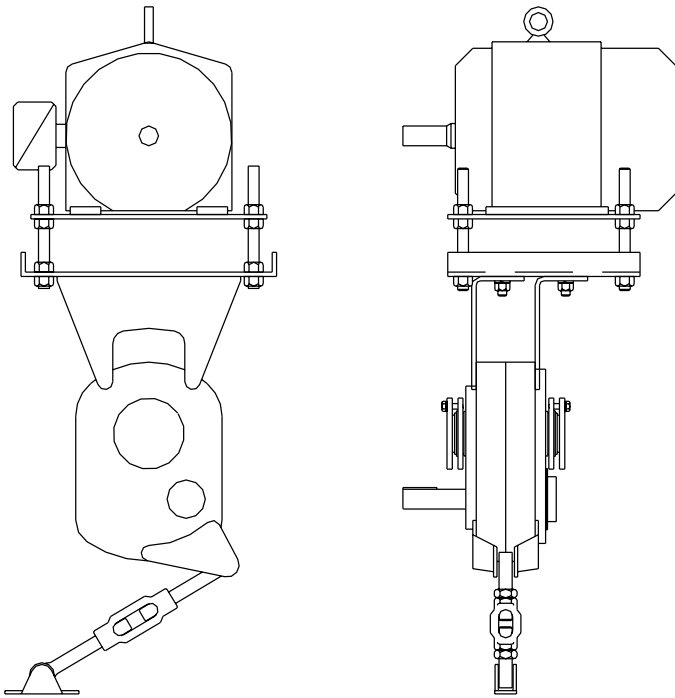

Figure 6 - Motor Mount Components

WARNING: Belt guard removed for illustration purposes. Do not operate if belt guard is not in place.

Motor Mount Installation:

The TA motor mount is designed to be installed on the output end of the reducer as shown in Figure 6. If bottom mounting is desired, use the optional TAB style.

TA1M Motor Mount:

Remove the required housing bolts on the output end of the reducer. Place the motor mount brackets in position and install the longer housing bolts supplied with the motor mount assembly. Do not fully tighten the housing bolts at this time.

Install the bottom plate to the motor mount brackets and tighten with the hardware provided. Next, tighten the housing bolts to the torque values listed in Table 6.

Install the four adjusting studs to the bottom plate using the jam nuts provided and securely tighten. These nuts will not require any further adjustment. Add one additional jam nut to each stud and thread approximately to the middle of the stud. Install the top motor plate on top of the jam nuts. Assemble the remaining jam nuts on studs to secure top motor plate. Do not fully tighten these nuts yet.

Mount motor, drive and driven sheaves, and v-belts.

Note: Mount driven sheave as close to the reducer housing as practical.

Adjust v-belts to the proper tension by adjusting the jam nuts and securely tighten.

Check all bolts to insure that they are securely tightened.

Straight Bore Reducer:

1. Disconnect and remove belt guard, v-drive, and motor mount as required. Disconnect torque arm rod from reducer adapter.
2. Loosen and remove the set screws in both output hub collars.
3. Remove the collar from the output hub closest to the end of the shaft. This will expose three puller holes in the output hub to permit the use of a three prong puller. In removing the reducer from the shaft, use care not to damage the reducer output hub.

Disassembly:

1. Drain all oil from the reducer.
2. Remove all locking collars, retaining rings, and bushing backup plated as required. Position the reducer on its side and remove all housing bolts. Gently separate the housing halves and open evenly to prevent damage to the parts inside. Remove the two dowel pins.
3. Lift input shaft, all gear assemblies, and bearing assemblies from housing.
4. Remove seals from housing.
5. Remove bearings from shafts and hubs. Be careful not to scratch or damage any assembly or seal area during bearing removal. The hub assembly can be disassembled for gear replacement but if scratching or grooving occurs on the hub, seal leakage will occur and the hub will need to be replaced.

TXT/HXT Reassembly:

1. Output Hub Assembly: Heat gear to 325°F to 350°F to shrink onto hub. Heat bearings to 270°F to 290°F to shrink onto hub. Any damage to the hub surfaces where the oil seals rub will cause leakage, making it necessary to replace the hub.
2. Input Shaft Assembly: Heat bearings 270°F to 290°F to shrink onto shaft. Press bearings on shaft.
3. Drive the two dowel pins into place in the right-hand housing half (backstop side).
4. Place R.H. housing half on blocks to allow for protruding end of output hub.
5. TXT/HXT 105 and TXT/HXT 205 reducers use ball bearings on all shafts and do not incorporate separate bearing cups and cones. No axial bearing adjustments are required.
6. Set the output hub gear assembly and the input pinion assembly into place in the housing. To avoid gear damage, carefully mesh these gear assemblies together when setting in housing. Make sure all bearings are properly seated.
7. Make sure both housing halves are clean. Apply a continuous 1/8" diameter bead of Dow Corning RTV732 sealant on the flange surface of the R.H. housing (make sure RTV is placed around all bolt holes). Set the left-hand housing half into position onto the dowel pins and gently tap with a soft hammer (rawhide, not lead hammer) until housing bolts can be used to draw housing halves together. Make sure reducer shafts do not bind while tightening housing bolts. Torque housing bolts per torque values listed in Table 6.
8. Install input and output seals. Lightly coat the seal lips with Mobilith AW2 All-Purpose grease or equivalent. The possibility of damage and consequent oil leakage can be decreased by covering all sharp edges with tape prior to seal installation. Seals should be pressed or tapped with a soft hammer evenly into place in the reducer housing, applying pressure only on the outer edge of the seals. Extreme care should be used when installing seals to avoid damage due to contact with sharp edges on the input shaft or output hub. A slight oil leak at the seals may be evident during initial running, but should disappear unless seals have been damaged.

9. Install bushing backup plates and snap rings on taper bushed reducers or hub collars on straight bore reducers and install backstop cover. Make sure all bolts are tightened to the correct torque values listed in Table 6.

Reducer Size	Bearing Endplay Values	
	Input	Output
TXT/HXT 105	N/A	N/A
TXT/HXT 205	N/A	N/A

Reducer Size	Housing Bolts	Output Seal Carrier	Input Seal Carrier
TXT/HXT 105	30 - 27	N/A	N/A
TXT/HXT 205	30 - 27	N/A	N/A

Reducer Size	Fastener Size	Torque in Ft.-Lbs.
TXT/HXT 105	10 - 24 x 3/8	5 - 4
TXT/HXT	205 10 - 24 x 3/8	5 - 4

REPLACEMENT PART AND KIT NUMBERS

Table 7-Part Numbers for Replacement Bearings

Reducer Size	Output Hub Bearing – LH and RH Sides	
	Dodge Part Number	Part Number
TXT/HXT 105	424020	6011NR
TXT/HXT 205	424022	6013NR

Reducer Size	Input Shaft Bearing – LH Input Side	
	Dodge Part Number	Part Number
TXT/HXT 105	424076	6206NR
TXT/HXT 205	424078	6028NR

Reducer Size	Input Shaft Bearing – RH Backstop Side	
	Dodge Part Number	Part Number
TXT/HXT 105	424012	6304NR
TXT/HXT 205	424000	305NR

NOTE: For actual reducer ratios, refer to Table 9.

Reducer Size	Ratio	Seal Kit	Output Hub Assembly		Bearing Kit(s)
			Taper Hub	Straight Hub	
TXT/HXT 105	5:1	See Parts List	390878	390151	389910 All
TXT/HXT205	5:1	See Parts List	392111	392110	389911 All

Notes:

Seal Kit consists of Input Seal, Output Seals, Backstop Cover Gasket and RTV Sealant.
Output Hub Assembly consists of Output Hub, Output Gear and Gear Key.
Bearing Kit consists of LH and RH Output Bearings and LH and RH Input Bearings.

Parts for TXT/HXT 105 & TXT/HXT 205 Straight and Tapered Bushed Single Reduction Reducers

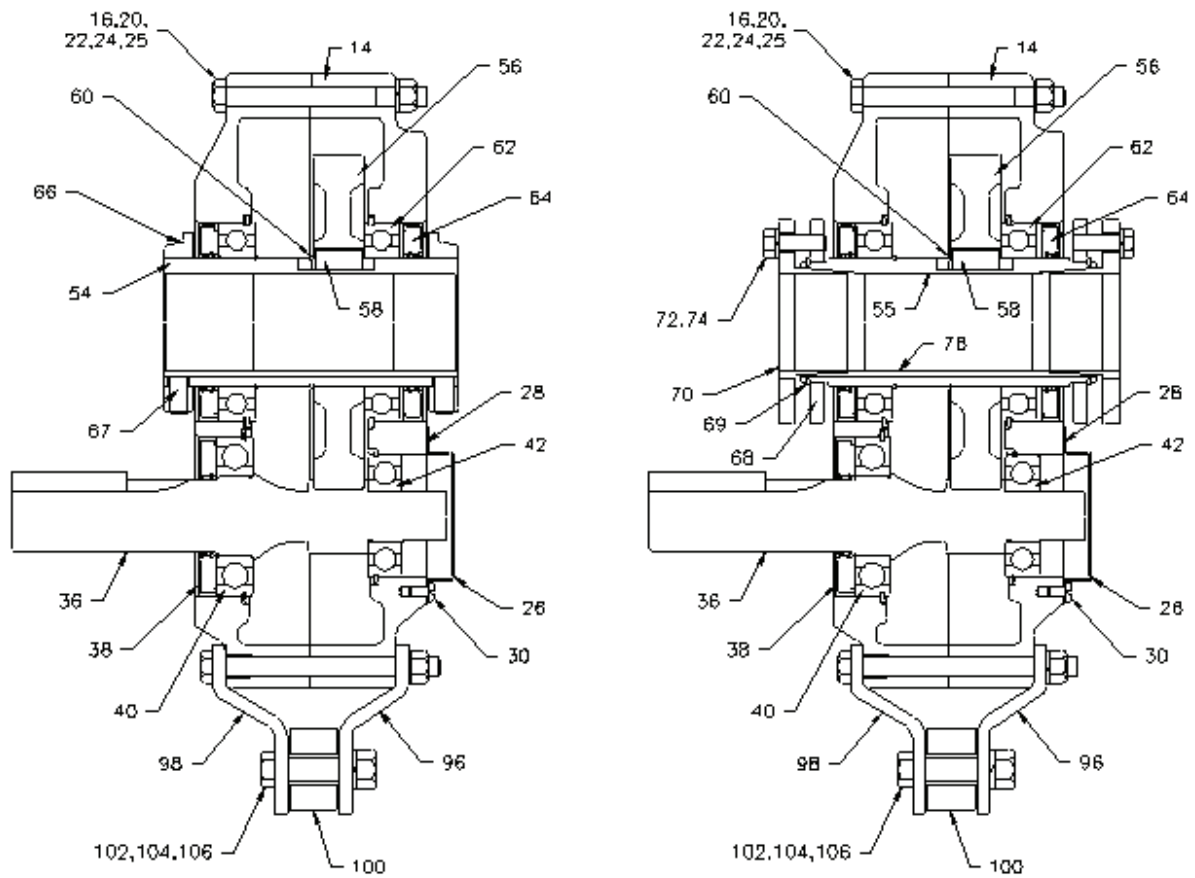

STRAIGHT BORE

TAPER BUSHED

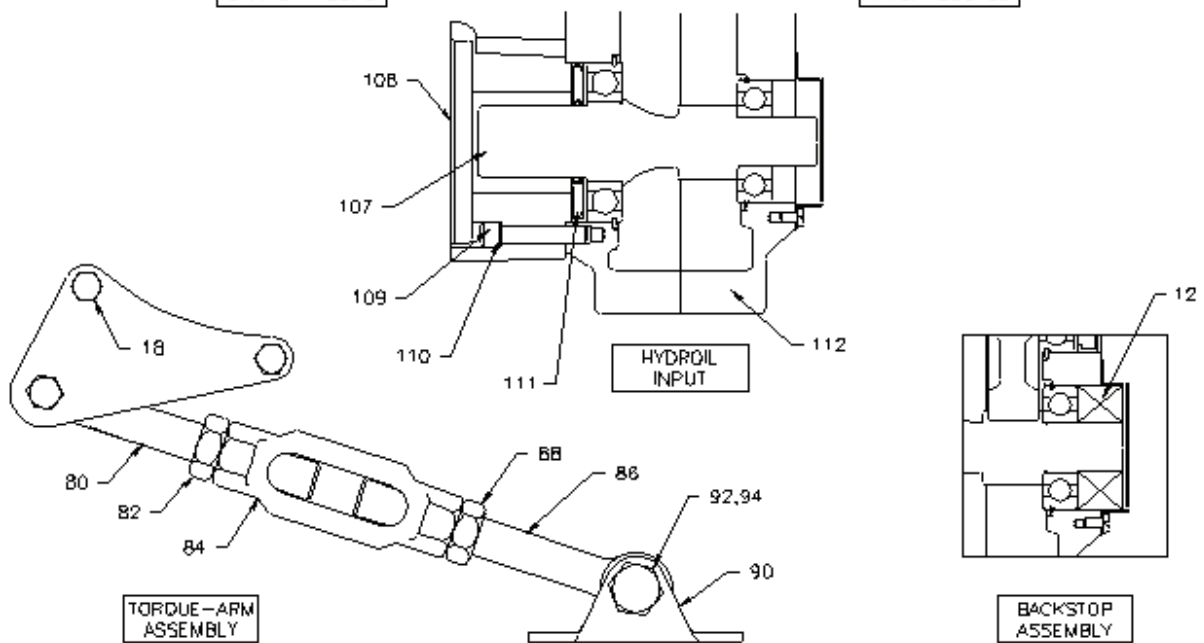

TORQUE-ARM ASSEMBLY

HYDROIL INPUT

BACKSTOP ASSEMBLY

**Parts for TXT/HXT 105 & TXT/HXT 205 Straight and Tapered Bushed
Single Reduction Reducers**

Reference	Description	Qty.	TXT/HXT 1	TXT/HXT 2
12	Backstop Assembly	1	242101	252101
14	TXT Housing LH	1	241322	242322
	TXT Housing RH	1	241323	242323
112	HXT Housing LH	1	241338	242314
	HXT Housing RH	1	241323	242323
16	Housing Bolt	②	411418	411418
18	Housing Bolt-Adapter And Lifting Lug	3	411420	411420
20	Lock-Washer	③	419011	419011
22	Hex Nut	③	407087	407087
①	Dowel Pin	2	420063	420092
①	RTV Sealant, Tube	1	465044	465044
①	Air Vent	1	900287	900287
①	Magnetic Oil Plug	1	430060	430060
25	Oil Plug ①	3	430031	430031
25	Smart Sensor Adaptor	1	966905	966905
26	Backstop Shaft Cover	1	242221	243221
30	Backstop Cover Screw	4	415022	415022
	Seal Kit ④	1	392119	392120
28	Backstop Cover Gasket ⑤	1	242220	243220
38	Input Oil Seal ⑤	1	251089	252063
64	Output Hub Oil Seal ⑤	2	241214	242113
36	Input Shaft with Pinion, 5:1 Ratio ⑥	1	251020	242214
41	Input Pinion Key	1	443013	443052
107	Hydroil Input Shaft with Pinion, 5:1 Ratio ⑥	1	251086	242215
	Bearing Replacement Kit ④	1	389910	389911
40	Input Pinion Bearing-LH, Input Side ⑤	1	424076	424078
42	Input Pinion Bearing-RH, Backstop Side ⑤	1	424012	424000
62	Output Hub Bearings ⑤	2	424020	424022
	Straight Bore Output Hub Assembly ⑥	1	390151	392110
54	Output Hub, Straight Bore ⑦	1	241208	242208
56	Output Gear ⑦	1	241007	242181
58	Output Gear Key ⑦	1	241217	443399
60	Output Hub Snap Ring ⑦	2	421013	421017
§	Straight Bore Output Hub Key ⑦	1	241296	242296
55	Taper Bore Output Hub Assembly ④	1	390878	392111
	Output Hub, Taper Bore ⑤	1	241265	242134
56	Output Gear ⑤	1	241007	242181
58	Output Gear Key ⑤	1	241217	443399
60	Output Hub Snap Ring ⑤	2	421013	421017
66	Straight Bore Output Hub Collar	2	241209	242209
67	Straight Bore Output Hub Collar Screw	4	400062	400094
68	Taper Bore Bushing Backup Plate	2	241266	242137
69	Bushing Backup Plate Retaining Ring	2	421111	421112

**Parts for TXT/HXT 105 & TXT/HXT 205 Straight and Tapered Bushed
Single Reduction Reducers**

Reference	Description	Qty.	TXT/HXT 1	TXT/HXT 2
70	Taper Bore Bushing Assembly ④			
	Bushing ⑤			
	1" Bore	1	241278	N/A
	1-1/16" Bore	1	241280	N/A
	1-1/8" Bore	1	241282	242146
	1-3/16" Bore	1	241286	242148
	1-1/4" Bore	1	241288	242150
	1-5/16" Bore	1	241290	242152
	1-3/8" Bore	1	241294	242154
	1-7/16" Bore	1	241292	242156
	1-1/2" Bore	1	N/A	242158
	1-5/8" Bore	1	N/A	242162
	1-11/16" Bore	1	N/A	242164
	1-3/4" Bore	1	N/A	242166
	1-15/16" Bore	1	N/A	242168
72	Bushing Screw ⑤	6	411405	411390
74	Lock Washer ⑤	6	419010	419010
76	Key, Taper Bore Bushing to Shaft ⑤			
	1" Bore	1	443274	N/A
	1-1/8" Bore	1	443271	443281
	1-3/16" Bore	1	241308	443281
	1-1/4" Bore	1	241307	443281
	1-5/16" Bore	1	241306	443280
	1-3/8" Bore	1	241310	443280
	1-7/16" Bore	1	241305	443282
	1-1/2" Bore	1	N/A	443282
	1-5/8" Bore	1	N/A	424172
	1-11/16" Bore	1	N/A	242171
	1-3/4" Bore	1	N/A	242170
	1-15/16" Bore	1	N/A	443283
①	Key, Bushing to Output Hub ⑤			
	1" Bore	1	443272	N/A
	1-1/8" Bore	1	443273	N/A
	1-1/8" to 1-1/2" Bore	1	N/A	443284
	Torque-Arm Assembly ④	1	241097	243097
80	Torque-Arm Rod End ⑤	1	241245	243245
82	RH Nut ⑤	1	407093	407095
84	Torque-Arm Turnbuckle ⑤	1	241246	243246
86	Torque-Arm Extension ⑤	1	241247	243247
88	LH Nut ⑤	1	407242	407244
90	Torque-Arm Fulcrum ⑤	1	241249	243249
92	Fulcrum Screw ⑤	1	411456	411484
94	Hex Nut ⑤	1	407091	407093
	Adapter Assembly ④	1	259151	259152
96	RH Torque-Arm Adapter Bracket ⑤	1	241242	242136
98	LH Torque-Arm Adapter Bracket ⑤	1	241241	242135
100	Adapter Bushing ⑤	1	242243	243243
102	Adapter Bolt ⑤	1	411412	411437
104	Lock Washer ⑤	1	419011	419012

Parts for TXT/HXT 105 & TXT/HXT 205 Straight and Tapered Bushed Single Reduction Reducers

Reference	Description	Qty.	TXT/HXT 1	TXT/HXT 2
106	Hex Nut ⑤	1	407087	407089
108	Hydraulic Motor Adapter	1	251087	252078
109	Adapter Screw	6	417090	417090
110	Lockwasher	6	419046	419046
111	Input Pinion Seal, Hydroil	1	251089	244211
①	Motor to Adapter Flange Screw	2	411456	411456
①	Motor to Adapter Flange Lock Washer	2	419013	419013

Notes:

- ① Not shown on drawing.
- ② 3 required on TXT/HXT 105 and 4 required on TXT/HXT 205
- ③ 6 required on TXT/HXT 105 and 7 required on TXT/HXT 205
- ④ Includes parts listed immediately below marked ⑤
- ⑤ Makes up assembly under which it is listed.
- ⑥ Includes parts listed immediately below marked ⑦
- ⑦ Makes up assembly under which it is listed.
- ⑧ See Table 9 for actual ratio.

Actual Ratios

Table 9 - Actual Ratios	
Reducer Size	Actual Ratio
TXT/HXT 105	5.62
TXT/HXT 205	5.29

ABB Motors and Mechanical Inc.
 5711 R. S. Boreham Jr. Street
 Fort Smith, AR 72901
 Ph: 1.479.646.4711

Mechanical Power Transmission Support
 Ph: 1.864.297.4800

new.abb.com/mechanical-power-transmission
baldor.com

© ABB Motors and Mechanical Inc.
 MN16013 (Replaces 499332)



All Rights Reserved. Printed in USA.
 11/19 Printshop 50