

PRODUCT NOTE

Dodge® modified mounted bearings

Solving mounted bearing contamination issues



Solution

A replacement of the standard bearings with an advanced triple lip seal and rubberized flinger was recommended.

The triple lip seal with rubberized flinger offers more protection from sand getting into the bearing than traditional seals which reduces contamination, the leading cause of failure on the sand conveyor.

To get more life out of the grease, standard grease in the bearing was replaced with synthetic grease.

Result

The new bearing design decreased user replacement events by 67%, allowing for more conveyor up-time and freeing up maintenance personnel.

Challenge: Are your bearings failing due to contamination?

A customer using portable sand conveyors for natural gas drilling was seeing only four months life from the bearings. The single lip seal was allowing contamination to enter the units. Frequent replacement of the bearings slowed production and posed a safety risk to maintenance crews due to the tight location of the bearings within the conveyor frame.

Triple lip seal and rubberized flinger keeps contamination out.

Synthetic lubrication lasts 4 times longer than conventional grease.

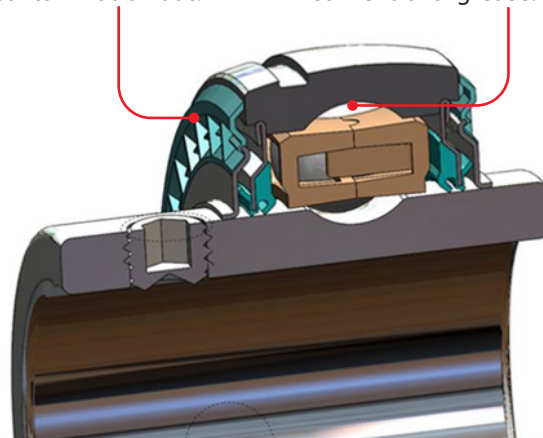

40 less bearings replaced / \$3,700 saved +
80 hours less labor / \$3,200 saved =

Total savings \$6,900 over one year

Dodge® modified mounted bearings

Mounted bearings that meet your application needs

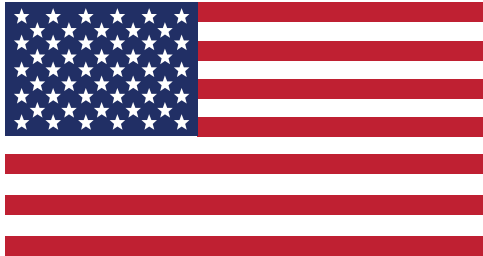

Local Manufacturing Video

Local manufacturing and customer service

Building Dodge mounted bearings locally, with modification capability, means that you get the bearing you need, when you need it. Being local also means that you get the availability and personal customer service you deserve.

Local sales engineers can work with you to review your specific standard bearing challenges and find the modification required for your specific application.

Dodge application engineering

brgpttechsupport@abb.com
864.284.5700

Mounted bearing modification capabilities include:



Sealing

- Accomodate high speeds and temperatures
- Minimize drag
- Protect bearings from harsh environments



Lubrication

- Supply specific greases and factory fill rates
- Provide bearings without grease for customer fill
- Plug bearings to reduce maintenance
- Plug bearings to avoid the addition of potentially incompatible grease by customer

Other modifications are available upon application and product review. Multiple modifications within a single unit may also be available.

Application specific mounted bearing modification capabilities include:



High temperature applications

- Designed especially for use in temperatures ranging from 215° to 400° F.



Low temperature applications

- Designed especially for use in temperatures ranging from -20° to -40° F

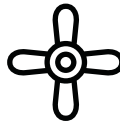

Air handling applications

- Specifically designed and tested for high speeds and quiet operation