

DODGE

Dodge® Motorized Torque-Arm II gear reducer (MTA)



MTA: The most reliable, heavy duty, right angle gearbox, available from stock is offered by the world's leading shaft mounted reducer company.



With 60 years of proven dependability and more than 1.8 million units in service throughout the world, Dodge Torque-Arm belt driven speed reducers are the standard of the industry and the benchmark to which others are compared. We have now introduced a line of heavy duty right angle direct drive Torque-Arm reducers for customers who need the power and performance in a compact, rugged gearbox for more demanding applications. Safety is always on our mind and MTA offers an extra level of safety when operating a shaft mounted reducer.

Heavy duty solution

- Available up to 100HP based on output speeds
- Right angle compact gearbox
- American Gear Manufacturers Association rated design offers approximately twice the bearing design life vs. the competition's design practices
- ALL heavy duty tapered roller bearing design, no light duty ball bearings
- Straddle mount input pinion gives maximum torque throughput, no press-fit pinion
- Patented sealing system

The Motorized Torque-Arm II is ATEX certified

- ATEX is a European Union ATmosphere EXplosive Directive
- Insures products are safe to operate in a hazardous environment
- I M2: group 1 category 2, safe in mining applications where dust is likely to occur
- II 2 GD c T4: group II category 2, safe for gas or dust environment surface temperature of reducer not to exceed T4=135°C (275°F)
- Tamb: ambient temperature between -30°C to +50°C

MOTORIZED TORQUE-ARM II SPEED REDUCER		RATIO		OIL QTY	
DODGE				POSS. D	
PART NUMBER		HP		U.S. QTS	
CLASS I RATING		HP AT		DRAIN, FLUSH, CLEAN MAGNETIC PLUG AND REFILL EVERY 6 MONTHS. INSPECT OIL OFTEN. SERVICE PER INSTRUCTION MANUAL.	
			INPUT RPM	PATENTED PROTECTED U.S. PATENT 5951198 OTHER PATENTS PENDING	
Tamb: -30°C to +50°C		WARNING: Do not open when an explosive atmosphere may be present.			
1 M2 / II 2 GD c T4		CE			
SRA 12 ATEX 6164		MFG. BY BALDOR ELEC. CO./FT. SMITH, AR 7201 USA			

Motorized Torque-Arm II design features

Optional Hydra-Lock breather

- Internal check valve system creates a nearly sealed system
- Filter element captures particles at 3 micron
- Visual cut for maintenance to verify oil quality and health of gearbox

TA II output gear

Heavy duty, cast iron housings

Harsh duty sealing system

- New advanced heavy duty sealing system improves sealing performance
- -40°F to +300° temperature range
- Excellent low temperature seal operation
- Extends seal service life up to 6 times over standard rubber seals

Twin tapered bushings

- Provide sturdy, concentric grip of the driven shaft on both sides of the reducer
- Eliminates the wobble and fretting corrosion associated with straight bore and single bushed reducers
- Installation and removal methods require no special tools
- Optional shortshaft kit to be used when replacing straight bore or single bushed reducer

Backstop ready

- The ONLY backstop of its kind that is designed to be compatible with lubricants containing extreme pressure (EP) additives
- Direction of rotation is field reversible
- No external lubrication required

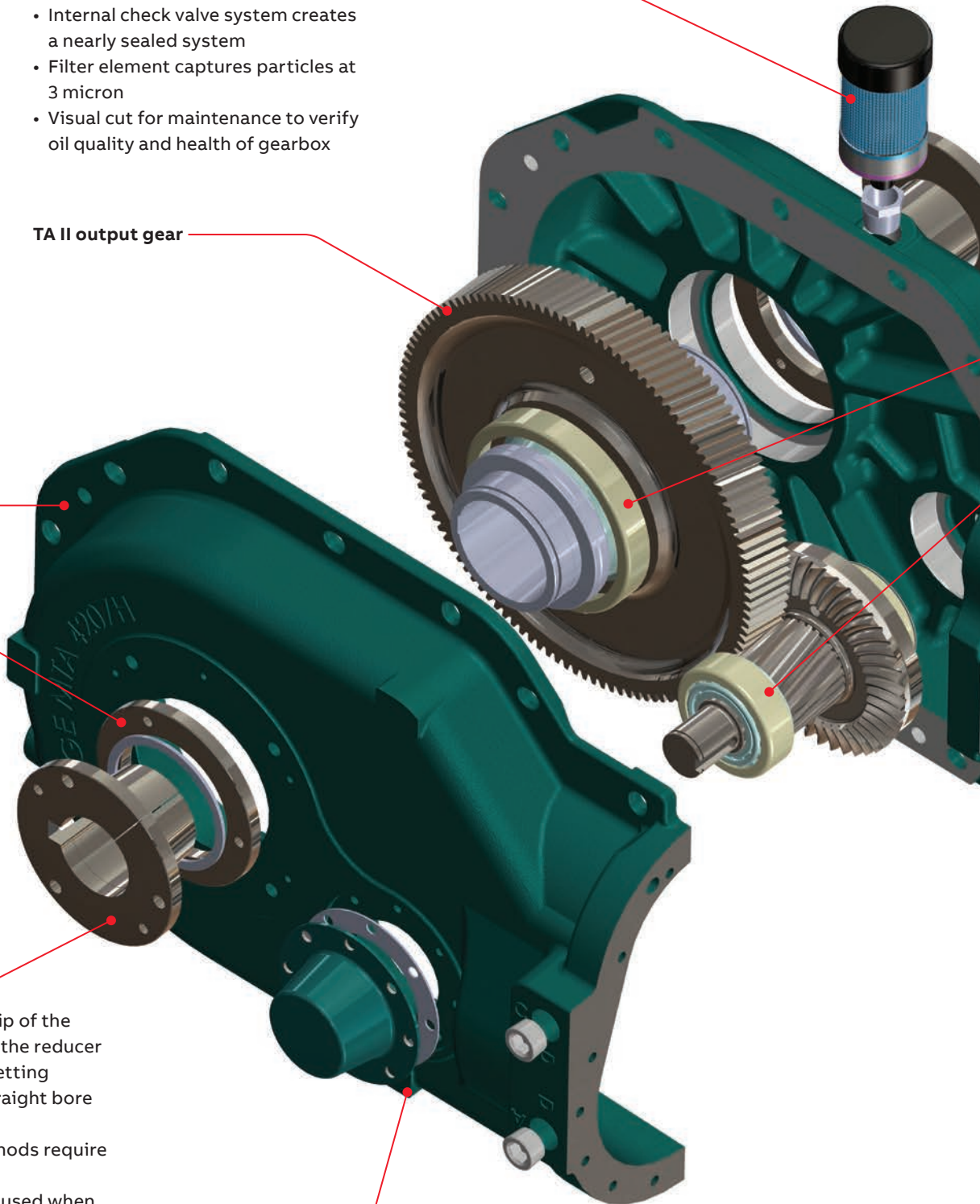

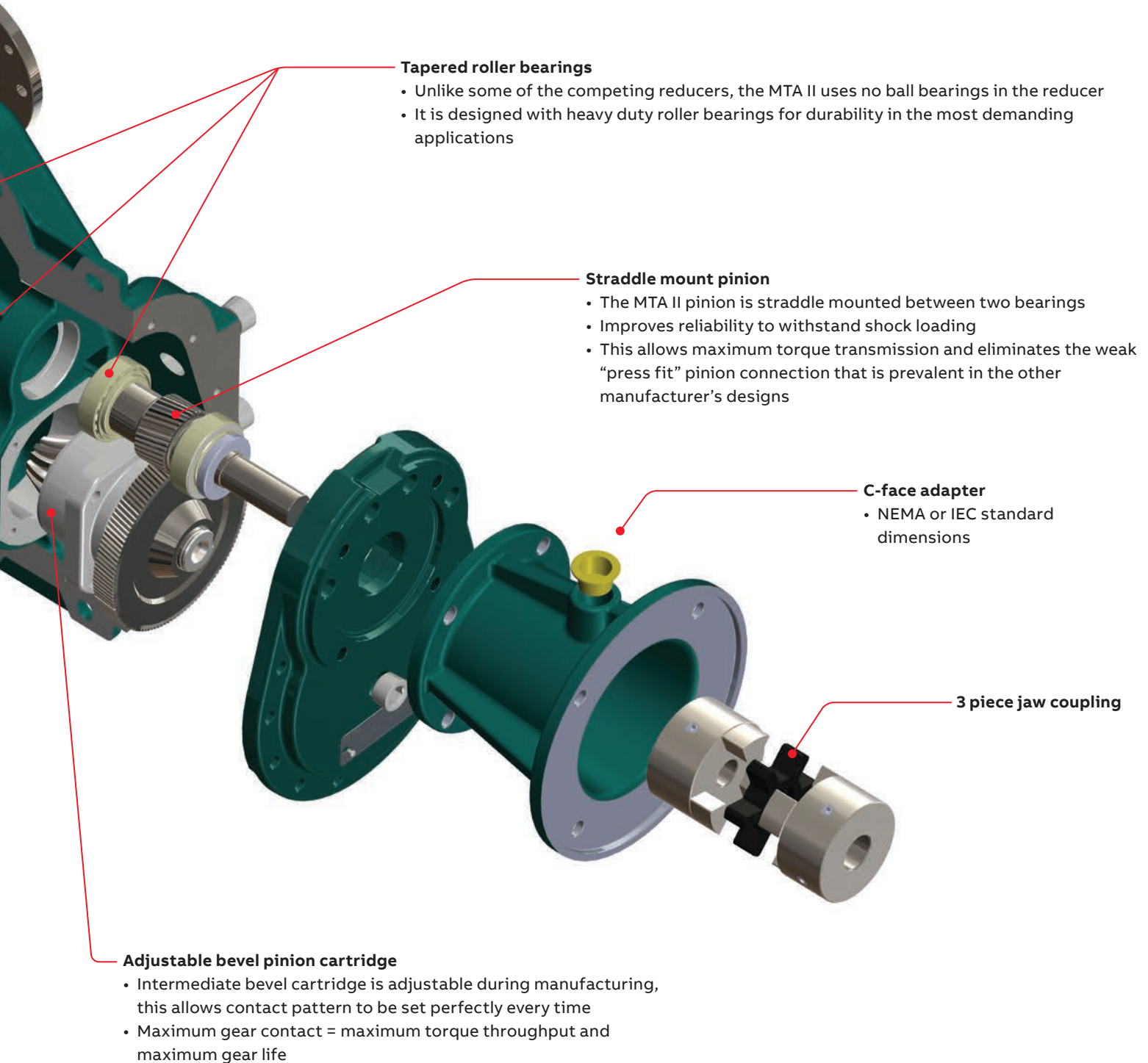

Dodge Motorized Torque-Arm II shaft mount accessories



Twin tapered bushings

- Easy on, easy off, no-wobble bushing system
- Features two fully split, ductile iron 8° taper bushings for reliable twin support
- Available in standard and short shaft versions
- Available in inch and metric bores
- Increased bore capability in many sizes

Tie Rod kit

- Ruggedly constructed
- Includes standard brackets
- Offers universal mounting options
- Keeps reducer stable and level
- Opposes reaction forces in running gearbox



Dodge Motorized Torque-Arm II screw conveyor drive accessories



CEMA bolt-on adapter

- Double lip seals on both the reducer end and trough end
- Open center for contamination disposal
- Optional adjustable waste packing kit offers proven sealing option for harsh environments

Screw conveyor drive shafts

- Made from high alloy steel to CEMA dimensions
- Standard three-bolt drilled
- Tapered fit ensures simple installation
- Patented locking plate provides mechanical shaft removal
- Optional stainless shafts are available



Motorized Torque-Arm II shaft mount accessories



ABS polymer safety bushing covers

- Covers rotating bushing bolts
- Additional layer of protection from contaminants
- Corrosion resistant
- Impact resistant heavy duty ABS polymer
- Available in totally closed and split/shaft through designs
- MTA II is drilled and tapped for cover installation



Optional position D breather kit

- One part number, 472300, for all sizes
- Includes sight glass, fittings, and totally enclosed chamber breather
- For use when reducer mounted in position D with motor end up
- Helps eliminate oil bubbling associated with high oil volume



ABB Ability Smart Sensor

- Safe, easy-to-use, wireless sensor
- Allows no contact, wireless monitoring of the health of Dodge mechanical products
- Allows users to reduce downtime, improve reliability, and operate safely

Motorized Torque-Arm II shaft mount accessories

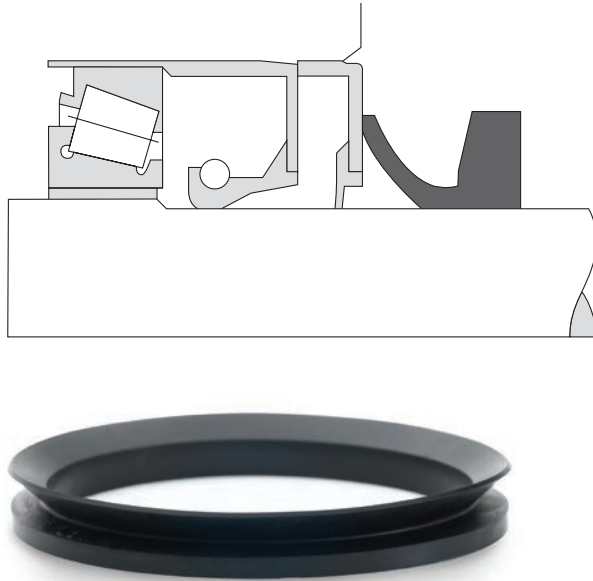

Harsh duty v-ring seal kit

- Rotates with driven shaft and acts as a flinger
- Keeps contaminants from coming in contact with excluder seal
- Easy installation – no tools required
- More resistant to water spray, and mild wash-down applications

More information on flyer FL1624

Dodge Motorized Torque-Arm II is designed for use in harsh duty environments. It is the go to gearbox for users demanding maximum bearing life and uptime from their equipment. When severe applications arise, Dodge answers with the new reliability kits for MTA II.

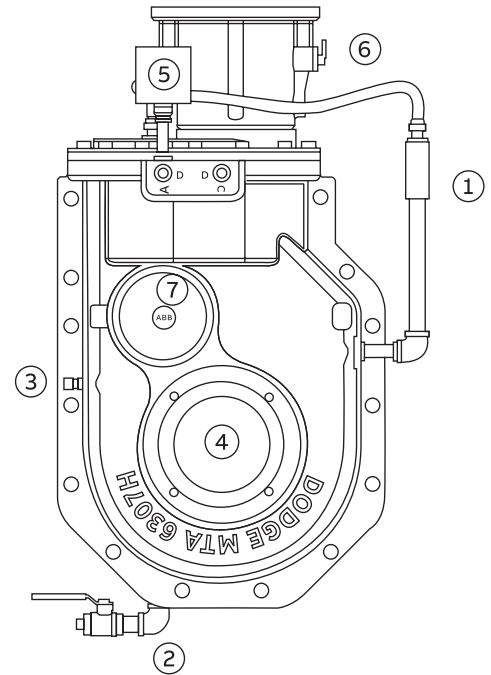

Reliability kit level 1 is used where users demand maximum uptime from critical equipment.

The level 1 kit includes:

1. Large vented oil sight tube with closed loop piping
2. Quick drain valve
3. Quick oil sampling port
4. ABS bushing covers, closed cover and a split cover for the backside
5. Position D breather kit with sight gauge and enclosed
6. Severe duty adapter plug

Reliability kit level 2 is used when condition monitoring is critical to the uptime reliability of the plant and adds:

7. ABB ability sensor

Select Motorized Torque-Arm II using Passport today



www.dodgepassport.abb.com

Motorized Torque-Arm II is available in multiple configurations

C-face reducer assembly includes:

Gearbox assembled to c-face adapter, coupling half installed, additional hardware included in box



C-face gearmotor assembly includes:

Pre-selected motors assembled to gearbox and adapter, ready to mount on equipment. Available configurations include: standard duty, for class 1 & 2 service; severe duty, for class 2 service; and high torque, for class 3 service.



Hydraulic gearmotor assembly includes:

Preselected hydraulic motor assembled to gearbox and adapter, ready to mount on equipment. Increase the conveying capacity of your portable hydraulically powered conveying equipment with the Dodge Hydraulic Motorized Torque Arm II (MTA II). The compact, high torque, right angle design of the Hydraulic MTA II allows for the use of a wider belt that can transport more material while maintaining the overall space constraints that limit the size of portable conveying equipment.



Torque-Arm family engineering catalog:



ABB Motors and Mechanical Inc.
6040 Ponders Court
Greenville, SC 29615
Ph: 1.864.287.4800

Mechanical Power Transmission Support
Ph: 1.864.297.4800

new.abb.com/mechanical-power-transmission