

---

MECHANICAL POWER TRANSMISSION

# Torque-Arm II

## Shaft mount gear reducer



---

# Dodge® Torque-Arm II

## Shaft mount gear reducers

Dodge Torque-Arm II shaft mount reducers deliver longer life in demanding applications. Designed with a patented harsh duty sealing system, twin tapered bushings, and the highest torque rating per case size, Torque-Arm II reducers provide maximum reliability with less maintenance to increase operating time and lower your total cost of ownership.

### Why Torque-Arm II?

#### Easy to use

- Flexible mounting to minimize inventory including: shaft mount, flange mount and screw conveyor drives
- Features twin tapered bushing system that makes installation and removal quick and easy

#### Reduce maintenance and increase uptime

- Industry leading sealing technology ensures maximum protection against contaminants extending the reducer life

#### Availability

- Available in 12 case sizes up to 400 Hp (300 kW)
- Torque ratings through 500,000 lb.-in. (56,500 Nm)
- Accommodates shaft sizes up to 7 inch (160 mm)
- Warranty is 36 months from date of manufacture or 18 months in service



# Reliability and safety

Decades of experience applying mechanical products throughout a wide range of industries means we understand the challenges that impact productivity. Safety is always a top priority, that is why the Torque-Arm II was designed with features and accessories that protect workers from installation through operation.

## Protect your employees

- Reducers are drilled and tapped for bushing covers to keep workers safe from rotating equipment
- Belt guards prevent injury during operation
- Backstops prevent reverse rotation when system stops
- Tie rod kit prevents system rotation by providing a safety link between the gear reducer and the structure

## ATEX Certified

- Environments that are mildly explosive become safer with use of ATEX certified reducers

## Reliable operation

- Built with tapered roller bearings to withstand shock loads, resulting in longer life
- Compatible with synthetic lubricant ensuring longest time between relubrication cycles

01 ATEX certified  
All nameplates are marked for use in some hazardous locations

DODGE		TORQUE-ARM II SPEED REDUCER		RATIO		OIL QTY		U.S.	
PART NUMBER		CLASS 1 RATING		HP AT		MAX INPUT RPM		POS. B	
USA PATENTS		kg		lb		SERVICE PER INSTRUCTION MANUAL		QTS	
5,667,333		6,272,941		6,530,138		6,272,941		6,530,138	
5,951,198		6,375,196		6,599,052		6,202,507		6,527,276	
6,253,640									
Tamb: -30°C to +50°C		WARNING Do not open when an explosive atmosphere may be present							
1M2 2K / 1/2 GD 2A T4		SIRA 04 ATEX 0360		MFG. BY BALDOR ELEC CO/FT SMITH, AR 72901 USA					

01



---

# Industry leading performance

## In tough applications

### Harsh duty seals to withstand any environment

- Dual sealing systems on all shafts consist of metal reinforced oil seals that are protected by an external metal shield and excluder lip
- Oil seals have an operating temperature range of -40°F to 300°F / -40°C to 150°C
- Compatible with both mineral and synthetic lubricants
- Easy to install, optional v-ring seals available for severe applications

### Engineered for extended operating life

- Manufactured with tapered roller bearings to withstand high shock loads
- Designed to exceed AGMA standards, the Torque-Arm II has twice the bearing life compared to most competitors
- 200% overload starting capacity ensures high efficiency and reliability

### Dodge twin tapered bushings for easy installation and removal

- System features two fully split, ductile iron, 8° taper bushings that provide sturdy concentric grip on the shaft
- Eliminates fretting corrosion, which can cause difficult removal
- No special tools required for installation or removal
- Full length key ensures maximum torque transmission
- Available in standard and short shaft designs to allow for easy replacement of straight bore and single bushed reducers

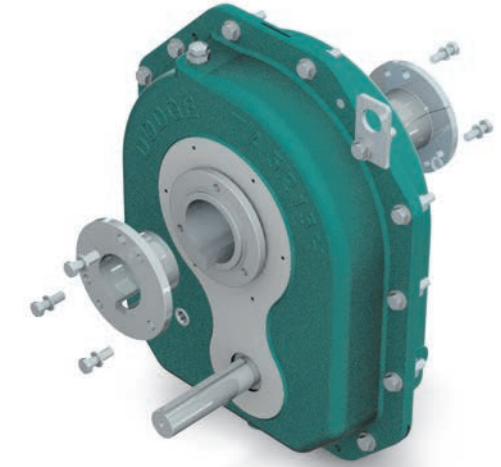

# Dodge Torque-Arm II

## Shaft mount speed reducer accessories

### Belt guard package

Allows for multiple height adjustments, featuring a lift-off cover construction.

### Motor mount

Provides stable mounting between motor and reducer to minimize overhung load and withstand heavy shock loading.

### Hydra-lock breather

To be used in humid or dusty environments, this optional breather's check valve system prevents ambient conditions and improves positive maintenance practices.



### Twin tapered bushing

Easy on, easy off assembly providing reliable support on both sides of reducer. Available for shorter shafts when replacing a single bushed or straight bore reducer.



### Backstop

Safety feature that prevents reverse rotation when system stops. Compatible with standard and EP lubricants without requiring external lubrication.

### Tie rod kit

Provides a safety link between reducer and structure to prevent system rotation. Standard rods and turnbuckles are now zinc coated for corrosion resistance.

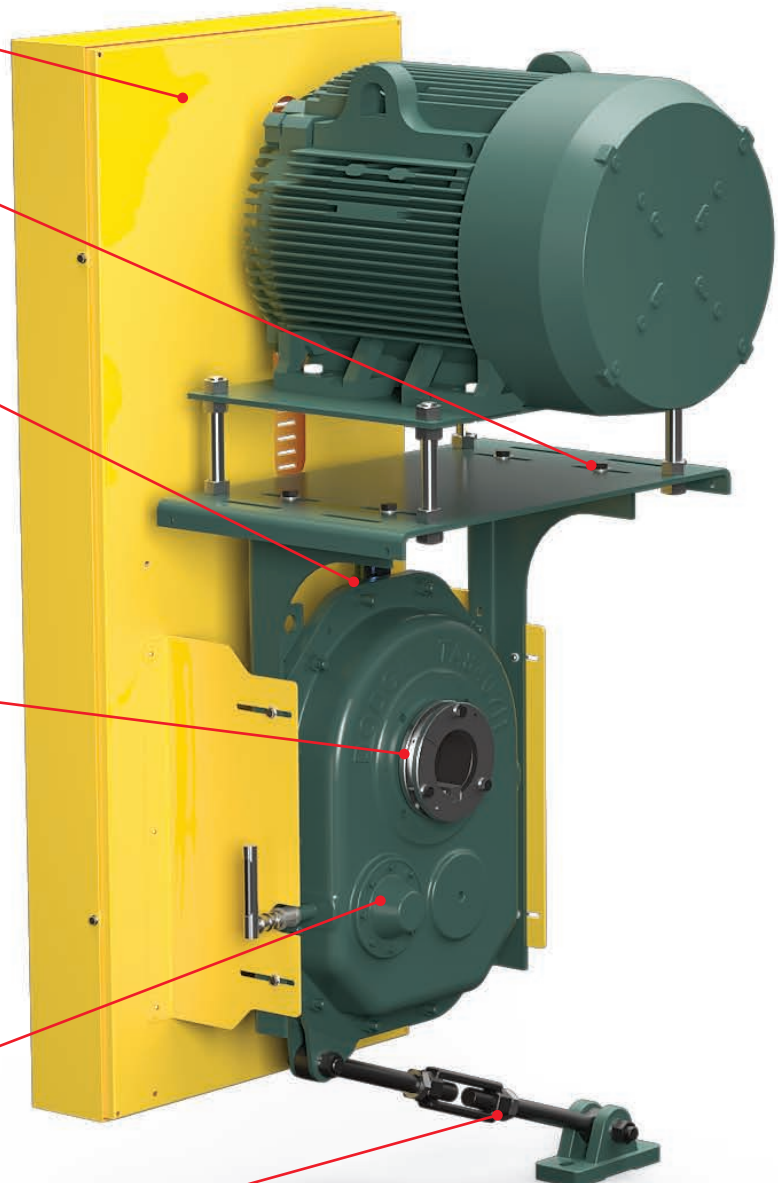

### Bushing covers

Reducers are pre-drilled and tapped to accept Dodge ABS polymer covers. Solid and pre-split versions available to accommodate both sides of reducers.

# Dodge Torque-Arm II

## Screw conveyor speed reducer accessories

### Belt guard package

Allows for multiple height adjustments, featuring a lift-off cover construction.

### Motor mount

Provides stable mounting between motor and reducer to minimize overhung load and withstand heavy shock loading.

### Hydra-lock breather

To be used in humid or dusty environments, this optional breather's check valve system prevents ambient conditions and improves positive maintenance practices.



### Adjustable packing kit

Additional kit to bolt on the CEMA adapter in hostile environments. Packing can be retightened & replaced to extend life.



### CEMA adapter

Featuring double lip seals on both surfaces. The adapter extends operating life and provides stable mounting to screw conveyor.

### CEMA driveshafts

Standard 3-hole screw conveyor drive shafts are the standard for higher torque applications.

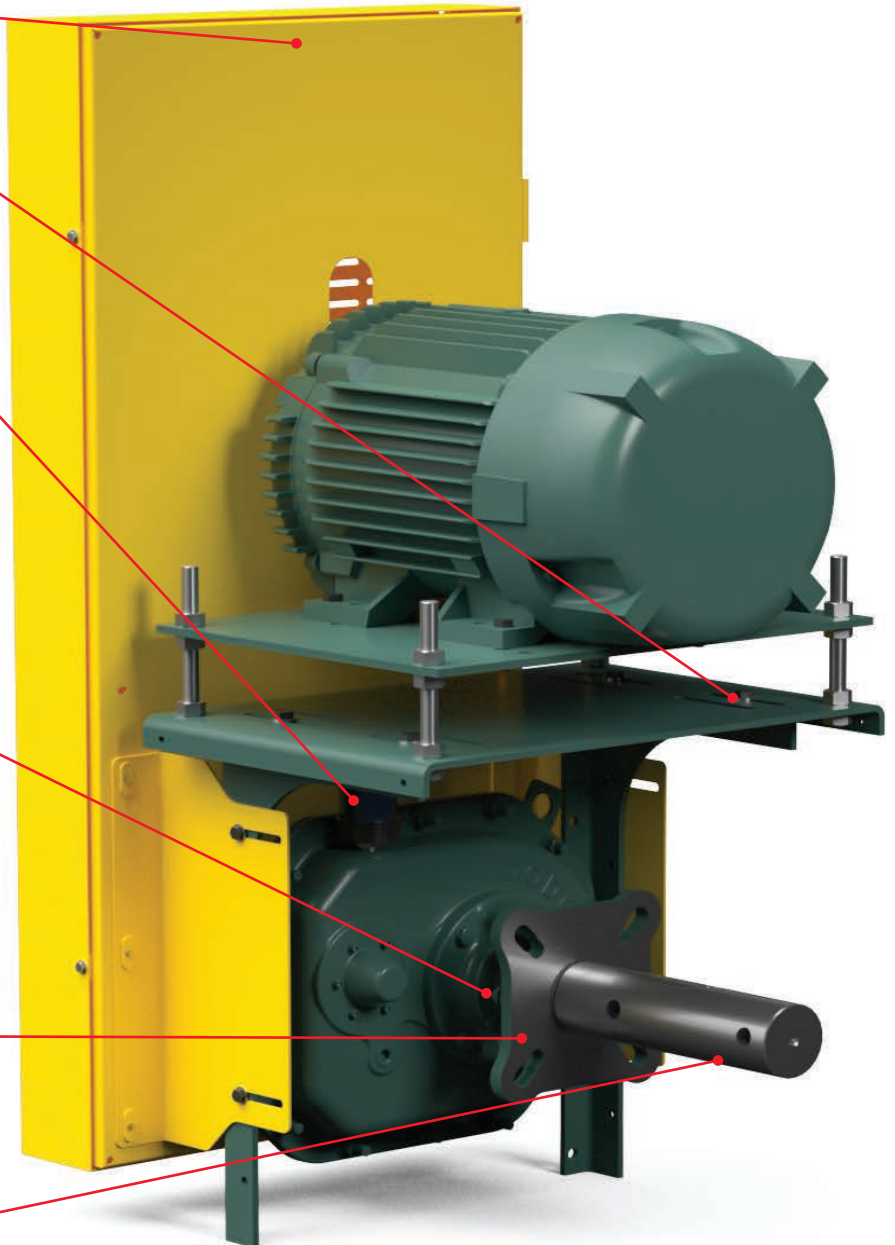

# Dodge passport

## Quick and easy selection of Torque-Arm II gear reducers



### Passport equals ease of doing business

Passport is an easy to use online selection program that utilizes an intuitive process to guide users through selection of Dodge mechanical power transmission products.

Passport significantly improves productivity, and ensures cost-effective and reliable selections through:

- real-time pricing and availability
- performance-matched components
- quote-to-order capabilities

[dodgepassport.abb.com](http://dodgepassport.abb.com)

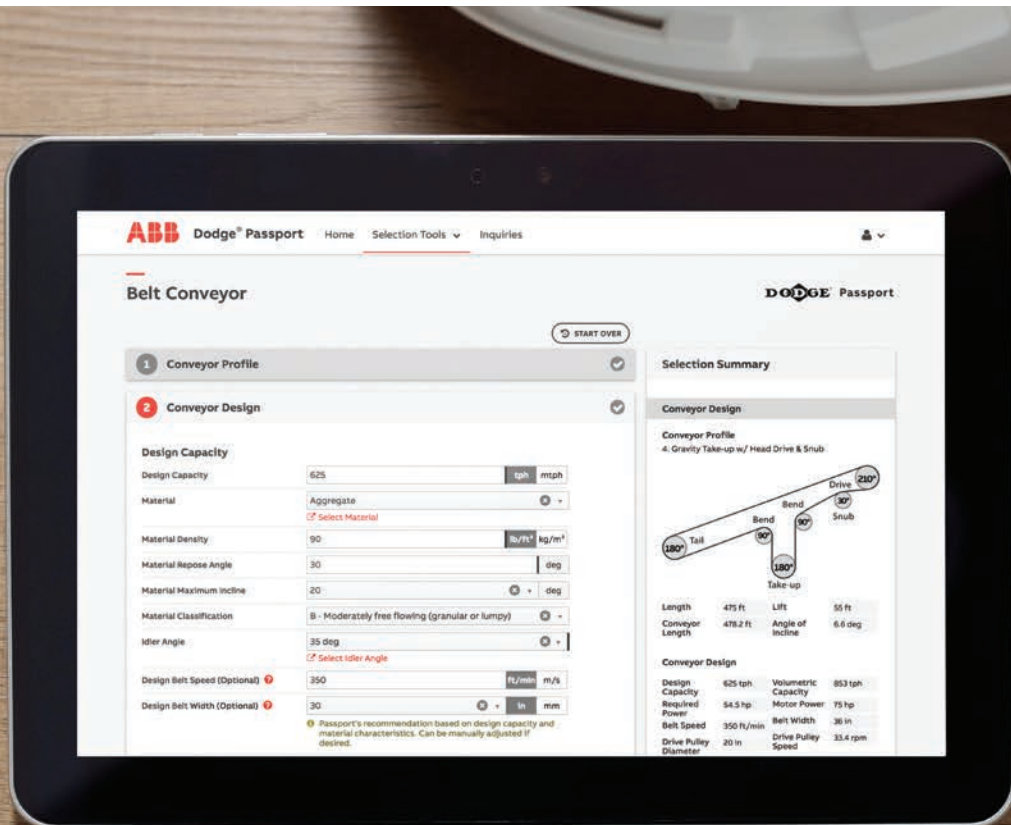

---

**ABB Motors and Mechanical Inc.**

5711 R.S. Boreham, Jr. Street  
Fort Smith, AR 72901  
Ph: 1.479.646.4711

Mechanical Power Transmission Support  
Ph: 1.864.297.4800

**[new.abb.com/mechanical-power-transmission](http://new.abb.com/mechanical-power-transmission)**

**Additional information**

We reserve the right to make technical changes or modify the contents of this document without prior notice. With regard to purchase orders, the agreed particulars shall prevail. ABB does not accept any responsibility whatsoever for potential errors or possible lack of information in this document.

We reserve all rights in this document and in the subject matter and illustrations contained therein. Any reproduction, disclosure to third parties or utilization of its contents – in whole or in parts – is forbidden without prior written consent of ABB.

© Copyright 2018 ABB. All rights reserved.  
Specifications subject to change without notice.

9AKK106468 05.2019 Litho 10,000

