

**BALDOR • RELIANCE**

---

# Customer information packet

## XT32502TS-5

250HP, 3575RPM, 3PH, 60HZ, 449TS, A44144M, TEF

Class - None

Division - Division II

## Specifications

Enclosure	TEFC
Frame	449TS
Frame Material	Iron
Frequency	60.00 Hz
Haz Area Class and Group	None
Haz Area Division	Division II
Motor Letter Type	Three Phase
Output @ Frequency	250.000 HP @ 60 HZ
Phase	3
Synchronous Speed @ Frequency	3600 RPM @ 60 HZ
Voltage @ Frequency	575.0 V @ 60 HZ
Agency Approvals	UR NEMA_PREMIUM NEMA PREMIUM CCSAUSEEV
Ambient Temperature	40 °C
Auxillary Box	No Auxillary Box
Base Indicator	Rigid
Bearing Grease Type	Polyrex EM (-20F +300F)
Current @ Voltage	214.000 A @ 575.0 V
Design Code	B
Drip Cover	No Drip Cover
Duty Rating	CONT
Efficiency @ 100% Load	95.8 %
Feedback Device	NO FEEDBACK
Heater Indicator	No Heater
High Voltage Full Load Amps	214.0 a
Insulation Class	F
Inverter Code	Inverter Ready
IP Rating	NONE
KVA Code	G
Max Speed	4500 rpm

## Part detail

Revision	B
Type	AC
Mech. spec.	
Base	
Status	PRD/A
Elec. spec.	A44WG5400
Layout	617427-460
Eff. date	07-08-2024
CD Diagram	416820-036
Poles	02
Leads	3#2/0 (02 per group)
Proprietary	False
Created date	09-16-2021

<b>Motor Lead Quantity/Wire Size</b>	6 @ 2/0 AWG
<b>Motor Standards</b>	NEMA
<b>Motor Type</b>	A44144M
<b>Mounting Arrangement</b>	F1
<b>Number of Poles</b>	2
<b>Overall Length</b>	49.46 IN
<b>Power Factor</b>	91
<b>Product Family</b>	General Industrial
<b>Pulley End Bearing Type</b>	Ball
<b>Pulley Face Code</b>	Standard
<b>Service Factor</b>	1.15
<b>Shaft Diameter</b>	2.375 IN
<b>Shaft Ground Indicator</b>	No Shaft Grounding
<b>Shaft Rotation</b>	Reversible
<b>Shaft Slinger Indicator</b>	Shaft Slinger
<b>Speed</b>	3575 rpm
<b>Speed Code</b>	Single Speed
<b>Starting Method</b>	Direct on line
<b>Thermal Device - Bearing</b>	None
<b>Thermal Device - Winding</b>	None

**Nameplate**

**NP4152LUA**

<b>CAT #</b>	XT32502TS-5			<b>SER</b>				<b>CC</b>	010A			
<b>SPEC</b>	A44-0001-5400			<b>RATING</b>	40C AMB-CONT							
<b>HZ</b>	<b>VOLTS</b>		<b>AMPS</b>	<b>RPM</b>	<b>HP</b>	<b>CODE</b>	<b>SF</b>	<b>DES</b>	<b>PF</b>	<b>NEMA NOM. EFF</b>		
60	575		214	3575	250	G	1.15	B	91	%	95.8 %	
										%	%	
<b>PH</b>	3	<b>CL</b>	F	<b>MAX RPM</b>	4500	<b>MAX CORR KVAR</b>	23					
<b>BRG</b>	<b>DE</b>	6313	<b>ODE</b>	6313	<b>ENCL</b>	TEFC	<b>FR</b>	449TS	<b>IP</b>	54		
<b>GREASE</b>	POLYREX EM						<b>MTR WT</b>	LBS				
	<b>CL I DIV 2 GRPS A,B,C,D</b>				<b>CL I ZONE 2 GRPS</b>			<b>IIA,IIB,IIC</b>		<b>TEMP T</b>	230 C	
<b>INV READY</b>	<b>CT</b>	2:1	<b>HZ</b>	30-60	<b>VT</b>	1000:1	<b>HZ</b>	0-60	<b>CHP</b>	1:1.25	<b>HZ</b>	60-75
<b>INV TEMP CL</b>	T2C	<b>C</b>	<b>USABLE AT</b>	N/A								
<b>SFA</b>	247											







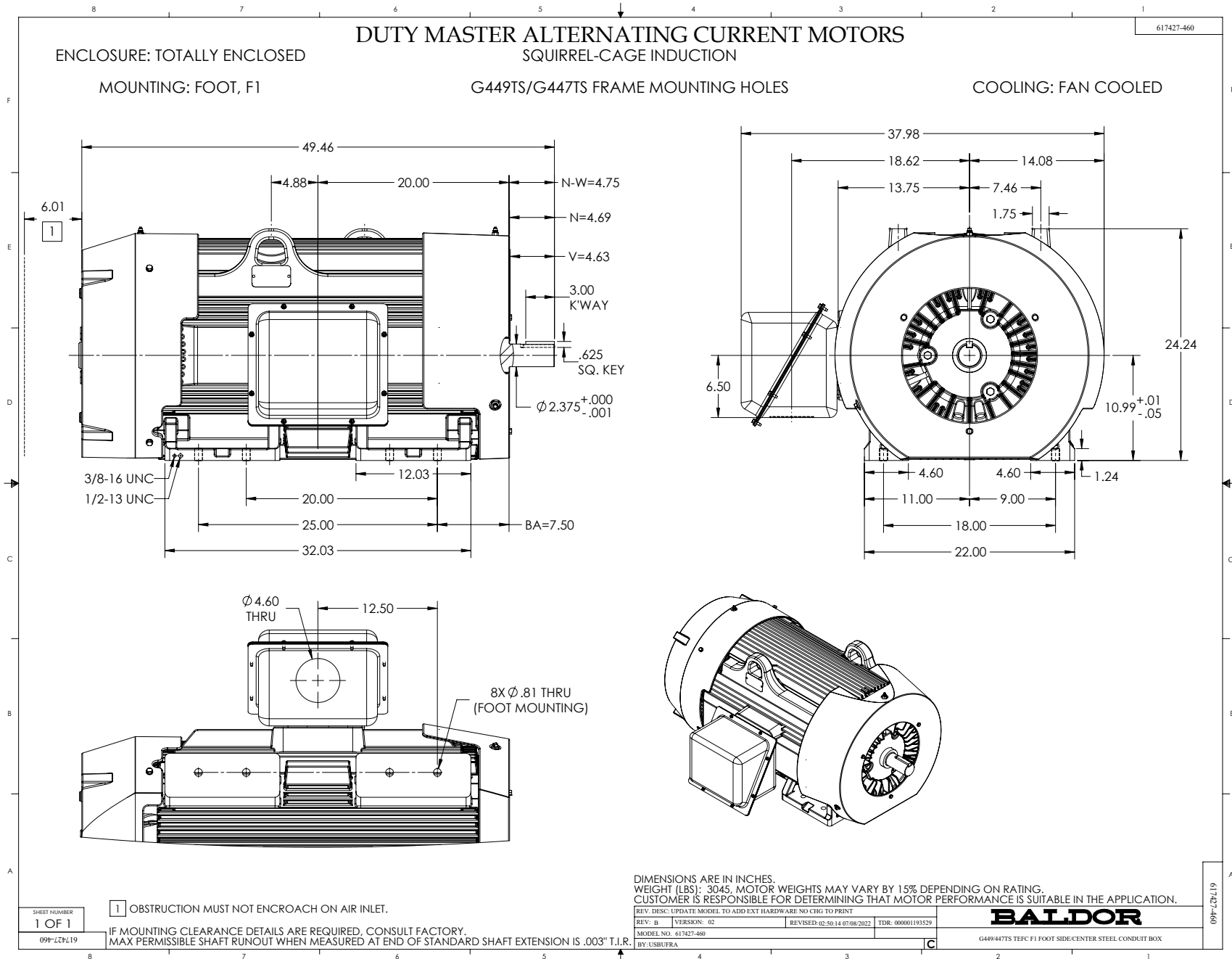



416820-036

A-C MOTOR  
CONNECTION DIAGRAM  
STANDARD 3 LEAD CONNECTED



(N.P. 1575-BA)

416820-036

REV. DESC: LOADED TO BUS, C/R 335225		
REV. LTR: -	VERSION: 00	TDR: 000000538207
FILE: \MGA\00000\682	REVISED: 11:54:06 04/30/2010	
MTL: -	BY: RAGRA	

**BALDOR**

CONN DIAG - STANDARD 3 LEAD  
SH 1 of 1