



---

# Customer information packet

## XT31506T-4

150HP, 1190RPM, 3PH, 60HZ, 447T, A44112M, TEFC

Class - None

Division - Division II

## Specifications

Enclosure	TEFC
Frame	447T
Frame Material	Iron
Frequency	60.00 Hz
Motor Letter Type	Three Phase
Output @ Frequency	150.000 HP @ 60 HZ
Phase	3
Synchronous Speed @ Frequency	1200 RPM @ 60 HZ
Voltage @ Frequency	460.0 V @ 60 HZ
XP Class and Group	None
XP Division	Division II
Agency Approvals	UR NEMA PREMIUM CSA EEV CCSA US
Ambient Temperature	40 °C
Auxillary Box	No Auxillary Box
Base Indicator	Rigid
Bearing Grease Type	Polyrex EM (-20F +300F)
Current @ Voltage	175.000 A @ 460.0 V
Design Code	B
Drip Cover	No Drip Cover
Duty Rating	CONT
Efficiency @ 100% Load	95.8 %
Feedback Device	NO FEEDBACK
Heater Indicator	No Heater
High Voltage Full Load Amps	175.0 a
Insulation Class	F
Inverter Code	Inverter Ready
IP Rating	NONE
KVA Code	G
Max Speed	2700 rpm

## Part detail

Revision	A
Type	AC
Mech. spec.	
Base	
Status	PRD/A
Elec. spec.	A44WG2229
Layout	617435-137
Eff. date	01-29-2021
CD Diagram	416820-036
Poles	06
Leads	3#2 (02 per group)
Proprietary	False
Created date	12-21-2020

<b>Motor Lead Quantity/Wire Size</b>	6 @ 2 AWG
<b>Motor Standards</b>	NEMA
<b>Motor Type</b>	A44112M
<b>Mounting Arrangement</b>	F1
<b>Number of Poles</b>	6
<b>Overall Length</b>	48.22 IN
<b>Power Factor</b>	84
<b>Product Family</b>	General Industrial
<b>Pulley End Bearing Type</b>	Ball
<b>Pulley Face Code</b>	Standard
<b>Service Factor</b>	1.15
<b>Shaft Diameter</b>	3.375 IN
<b>Shaft Ground Indicator</b>	No Shaft Grounding
<b>Shaft Rotation</b>	Reversible
<b>Shaft Slinger Indicator</b>	Shaft Slinger
<b>Speed</b>	1190 rpm
<b>Speed Code</b>	Single Speed
<b>Starting Method</b>	Direct on line
<b>Thermal Device - Bearing</b>	None
<b>Thermal Device - Winding</b>	None

**Nameplate**

**NP4152LUA**

<b>CAT #</b>	XT31506T-4		<b>SER</b>			<b>CC</b>	010A					
<b>SPEC</b>	A44-9771-2229		<b>RATING</b>	40C AMB-CONT								
<b>HZ</b>	<b>VOLTS</b>		<b>AMPS</b>	<b>RPM</b>	<b>HP</b>	<b>CODE</b>	<b>SF</b>	<b>DES</b>	<b>PF</b>	<b>NEMA NOM. EFF</b>		
60	460		175	1190	150	G	1.15	B	84 %	95.8 %		
									%		%	
<b>PH</b>	3	<b>CL</b>	F	<b>MAX RPM</b>	2700	<b>MAX CORR KVAR</b>	38	<b>USABLE AT 208V</b>	----	A		
<b>BRG</b>	<b>DE</b>	6318	<b>ODE</b>	6318	<b>ENCL</b>	TEFC	<b>FR</b>	447T	<b>IP</b>	54		
<b>GREASE</b>	POLYREX EM				<b>MTR WT</b>			<b>LBS</b>				
	<b>CL I DIV 2 GRPS A,B,C,D</b>			<b>CL I ZONE 2 GRPS</b>			<b>IIA,IIB,IIC</b>		<b>TEMP T</b>	200	C	
<b>INV READY</b>	<b>CT</b>	4:1	<b>HZ</b>	15-60	<b>VT</b>	0-60	<b>HZ</b>	1000:1	<b>CHP</b>	60-90	<b>HZ</b>	1:1.5
<b>INV TEMP CL</b>	T3	C	<b>USABLE AT</b>	50HZ 125HP 380V 177A					1.00			







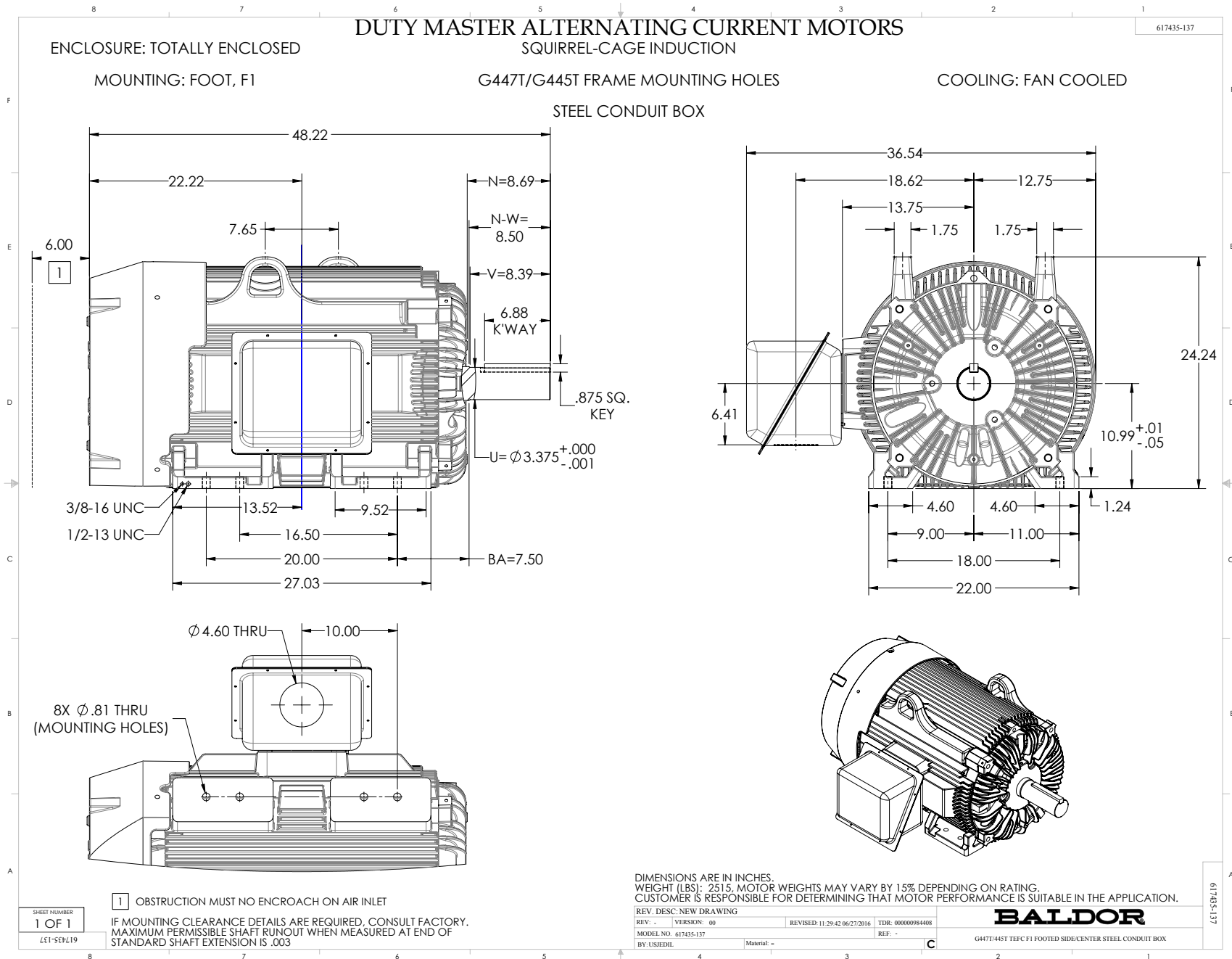



416820-036

A-C MOTOR  
CONNECTION DIAGRAM  
STANDARD 3 LEAD CONNECTED



(N.P. 1575-BA)

416820-036

REV. DESC: LOADED TO BUS, C/R 335225		
REV. LTR: -	VERSION: 00	TDR: 000000538207
FILE: \MGA\00000\682	REVISED: 11: 54: 06 04/30/2010	
MTL: -	BY: RAGRA	

**BALDOR**

CONN DIAG - STANDARD 3 LEAD  
SH 1 of 1