

BALDOR • RELIANCE

Customer information packet

XL050742A

0.75HP, 1750RPM, 1PH, 60HZ, 56, 3528L, XPFC, F1

Class - CLI GP D; CLII GP F,G

Division - Division I

Specifications

Enclosure	XPFC
Frame	56
Frame Material	Steel
Frequency	60.00 Hz
Motor Letter Type	Cap Start, Induction Run
Output @ Frequency	.750 HP @ 60 HZ
Phase	1
Synchronous Speed @ Frequency	1800 RPM @ 60 HZ
Voltage @ Frequency	115.0 V @ 60 HZ 230.0 V @ 60 HZ
XP Class and Group	CLI GP D; CLII GP F,G
XP Division	Division I
Agency Approvals	CSA UR
Ambient Temperature	40 °C
Auxillary Box	No Auxillary Box
Auxillary Box Lead Termination	None
Base Indicator	Rigid
Bearing Grease Type	Polyrex EM (-20F +300F)
Blower	None
Current @ Voltage	11.200 A @ 115.0 V 5.600 A @ 230.0 V
Design Code	N
Drip Cover	No Drip Cover
Duty Rating	CONT
Efficiency @ 100% Load	70.0 %
Electrically Isolated Bearing	Not Electrically Isolated
Feedback Device	NO FEEDBACK
Heater Indicator	No Heater
High Voltage Full Load Amps	5.6 a
Insulation Class	B
Inverter Code	Not Inverter

Part detail

Revision	C
Type	AC
Mech. spec.	
Base	
Status	PRD/A
Elec. spec.	35WGA0040
Layout	35LYE353
Eff. date	06-29-2021
CD Diagram	CD0008
Poles	04
Leads	6#18,1#14 4TH
Proprietary	False
Created date	05-05-2021

IP Rating	NONE
KVA Code	M
Lifting Lugs	No Lifting Lugs
Locked Bearing Indicator	No Locked Bearing
Motor Lead Termination	Flying Leads
Motor Standards	NEMA
Motor Type	3528L
Mounting Arrangement	F1
Number of Poles	4
Overall Length	15.15 IN
Power Factor	62
Product Family	General Purpose
Pulley Face Code	Standard
Rodent Screen	None
Service Factor	1.00
Shaft Diameter	0.625 IN
Shaft Ground Indicator	No Shaft Grounding
Shaft Rotation	Reversible
Speed	1750 rpm
Speed Code	Single Speed
Starting Method	Direct on line
Thermal Device - Bearing	None
Thermal Device - Winding	None
Vibration Sensor Indicator	No Vibration Sensor
Winding Thermal 1	Automatic Thermal Overload
Winding Thermal 1 Location	EP
Winding Thermal 2	None
XP Temp Code	T4

Nameplate

NP0016XPSL					
NO.		CC			
SER. #					
SPEC	35-0000-1159				
CAT.NO.	XL050742A				
H.P.	.75	T. CODE	T4		
VOLTS	115/230				
AMPS	10.8/5.4				
R.P.M.	1750 35WGA0040				
HZ	60	PH	1	CLASS	B
SER.F.	1.00	DES	N	CODE	M
RATING	40C AMB-CONT				
FRAME	56	NEMA NOM. EFF			70
USABLE AT 208V		PF	68		
BLANK	NEMA MG-1 PART 5, IP54				

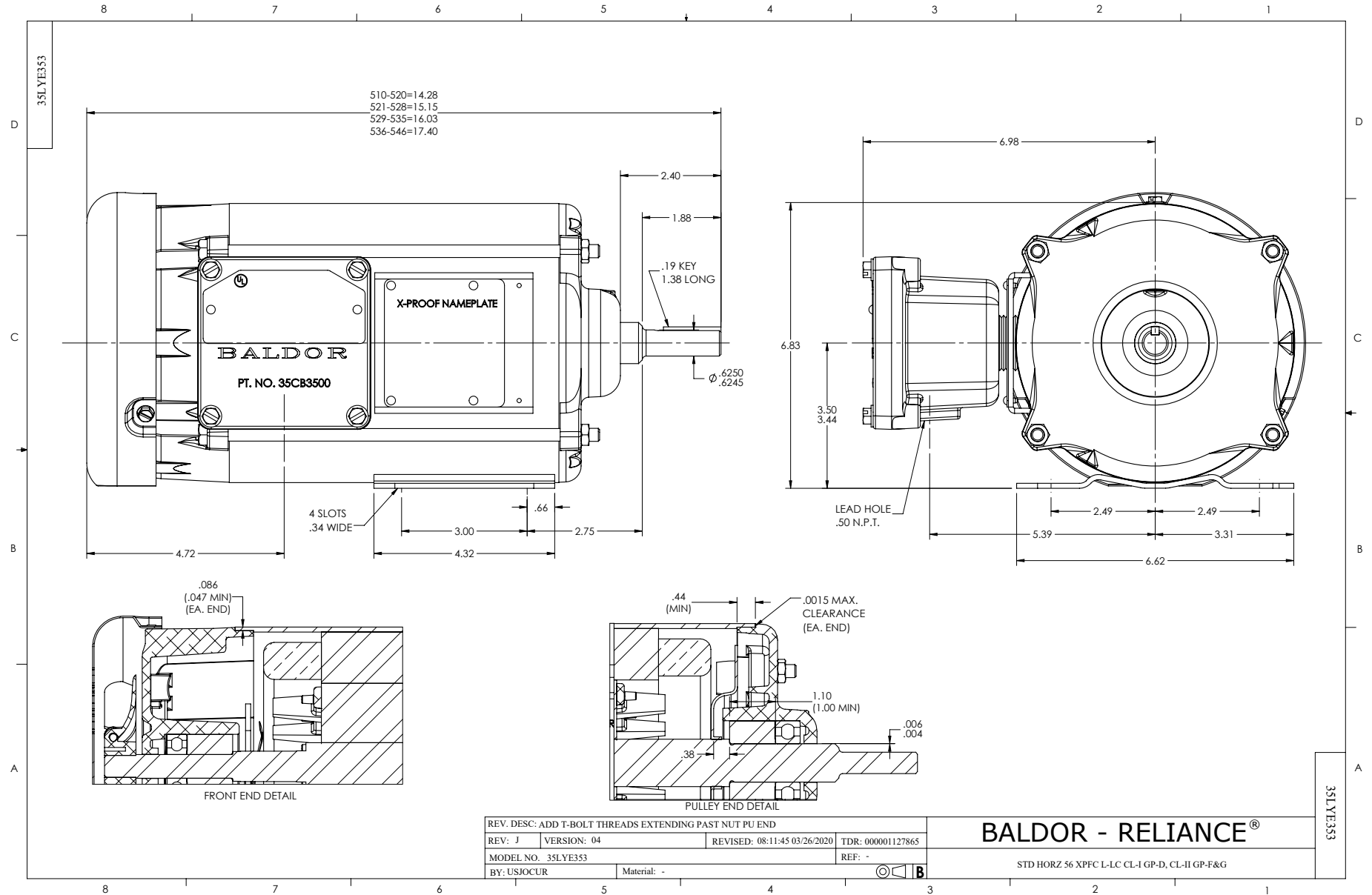

35LYG792

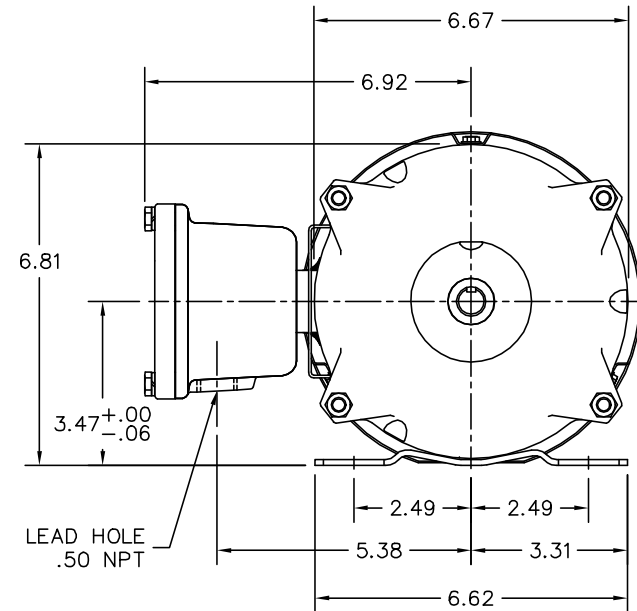
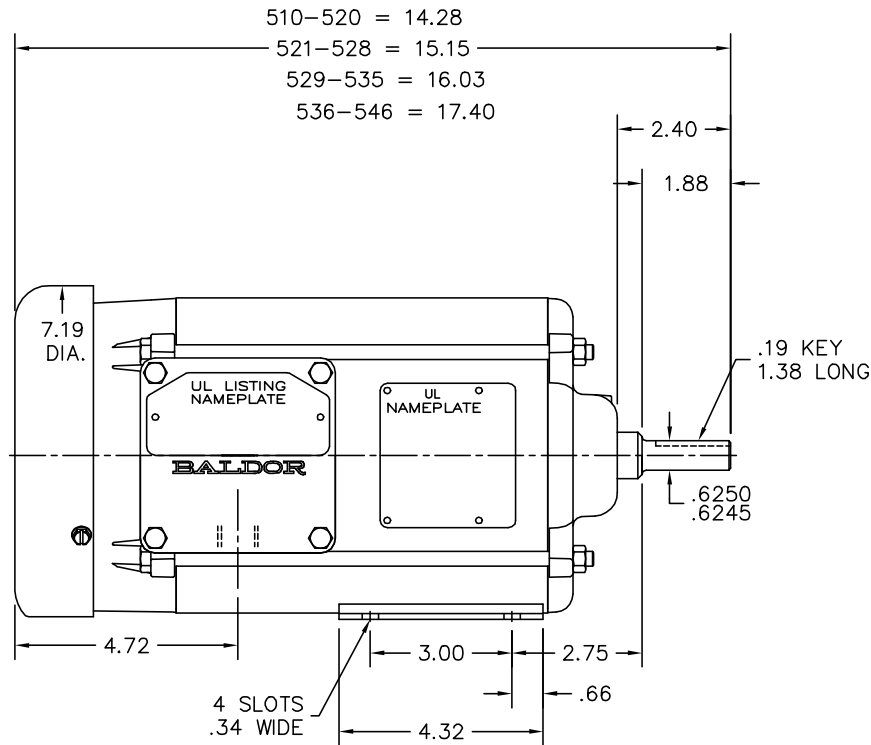

CUSTOMER IS RESPONSIBLE FOR DETERMINING THAT BALDOR'S PRODUCT WILL PERFORM SUITABLY IN THE INTENDED APPLICATION.

REV. DESC: UPDATE LAYOUT		
REV. LTR: E	VERSION: 01	TDR: 00000842537
FILE: \AAA\00033\367	REVISED: 09:14:05 03/14/2014	BY: ENBENBO
MTL: -	☉ □	

BALDOR

STD HOR 56 XPFC X35L CL I GP D W/T*STAT

SH 1 of 1

35LYG792

CD0008

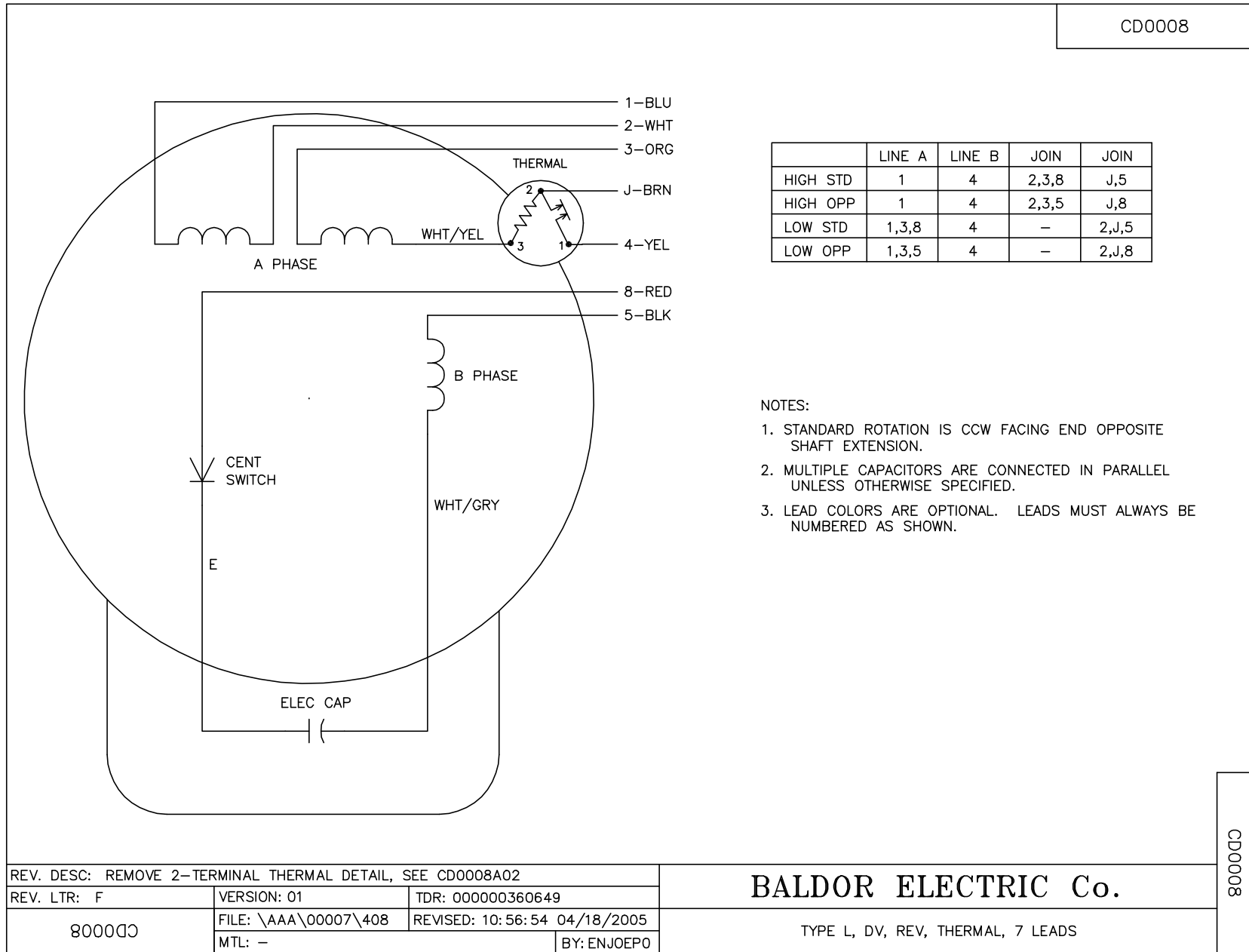

	LINE A	LINE B	JOIN	JOIN
HIGH STD	1	4	2,3,8	J,5
HIGH OPP	1	4	2,3,5	J,8
LOW STD	1,3,8	4	-	2,J,5
LOW OPP	1,3,5	4	-	2,J,8

NOTES:

1. STANDARD ROTATION IS CCW FACING END OPPOSITE SHAFT EXTENSION.
2. MULTIPLE CAPACITORS ARE CONNECTED IN PARALLEL UNLESS OTHERWISE SPECIFIED.
3. LEAD COLORS ARE OPTIONAL. LEADS MUST ALWAYS BE NUMBERED AS SHOWN.

REV. DESC: REMOVE 2--TERMINAL THERMAL DETAIL, SEE CD0008A02		
REV. LTR: F	VERSION: 01	TDR: 000000360649
800000	FILE: \AAA\00007\408	REVISED: 10:56:54 04/18/2005
	MTL: -	BY: ENJOEPO

BALDOR ELECTRIC Co.

TYPE L, DV, REV, THERMAL, 7 LEADS

CD0008