

ABB BALDOR RELIANCE III

Customer information packet

VHECP4109T

40HP, 3540RPM, 3PH, 60HZ, 324HP, 1240M, TEFC, F

Class - None

Division - Not Applicable

Specifications

Enclosure	TEFC
Frame	324HP
Frame Material	Iron
Frequency	60.00 Hz
Haz Area Class and Group	None
Haz Area Division	Not Applicable
Motor Letter Type	Three Phase
Output @ Frequency	40.000 HP @ 60 HZ
Phase	3
Synchronous Speed @ Frequency	3600 RPM @ 60 HZ
Voltage @ Frequency	230.0 V @ 60 HZ 460.0 V @ 60 HZ
Agency Approvals	UR CSA CSA EEV
Ambient Temperature	40 °C
Auxiliary Box	NO AUXILLARY BOX
Auxiliary Box Lead Termination	None
Base Indicator	No Mounting
Bearing Grease Type	Polyrex EM (-20F +300F)
Blower	None
Current @ Voltage	90.000 A @ 230.0 V 45.000 A @ 460.0 V
Design Code	A
Drip Cover	Drip Cover
Duty Rating	CONT
Efficiency @ 100% Load	93.0 %
Electrically Isolated Bearing	Not Electrically Isolated
Feedback Device	NO FEEDBACK
Front Face Code	Standard
Front Shaft Indicator	None
Heater Indicator	No Heater

Part Detail

Revision	AB
Type	AC
Mech. spec.	12S033
Base	
Status	PRD/A
Elec. spec.	12WGX906
Layout	12LYS033
Eff. date	12-09-2025
CD Diagram	CD0180
Poles	02
Leads	9#8
Proprietary	False
Created date	10-03-2008

High Voltage Full Load Amps	45.0 a
Insulation Class	F
Inverter Code	Inverter Ready
KVA Code	H
Lifting Lugs	Vertical Lifting Lugs
Locked Bearing Indicator	Locked Bearing
Motor Lead Exit	Ko Box
Motor Lead Quantity/Wire Size	9 @ 8 AWG
Motor Lead Termination	Flying Leads
Motor Standards	NEMA
Motor Type	1240M
Mounting Arrangement	F1
Number of Poles	2
Overall Length	34.72 IN
Power Factor	90
Product Family	Super-E Chemical Processing
Pulley End Bearing Type	Ball
Pulley Face Code	P-Base
Pulley Shaft Indicator	P-Base Groove & Key
Rodent Screen	None
Service Factor	1.15
Shaft Diameter	1.625 IN
Shaft Extension Location	Pulley End
Shaft Ground Indicator	No Shaft Grounding
Shaft Rotation	Reversible
Shaft Slinger Indicator	No Slinger
Speed	3540 rpm
Speed Code	Single Speed
Starting Method	Direct on line
Thermal Device - Bearing	None
Thermal Device - Winding	None
Vibration Sensor Indicator	No Vibration Sensor
Winding Thermal 1	None
Winding Thermal 2	None

Nameplate

NP1260									
CAT.NO.	VHECP4109T								
SPEC.	12S033X906G1								
HP	40								
VOLTS	230/460								
AMP	90/45								
RPM	3540								
FRAME	324HP	HZ	60	PH	3				
SER.F.	1.15	CODE	H	DES	A	CL	F		
NEMA-NOM-EFF	93	PF	90						
RATING	40C AMB-CONT								
CC	010A								
DE	6312	ODE	6311						
ENCL	TEFC	SN							

ABB Motors and Mechanical Inc.

WINDING # 12WGX906

Typical performance - not guaranteed values.

40 HP 3 PH 60 HZ 3540 RPM 460 V 1240M

TORQUES (LB-FT): PO=236 PU=62.9 LR=80.2 LRA=326

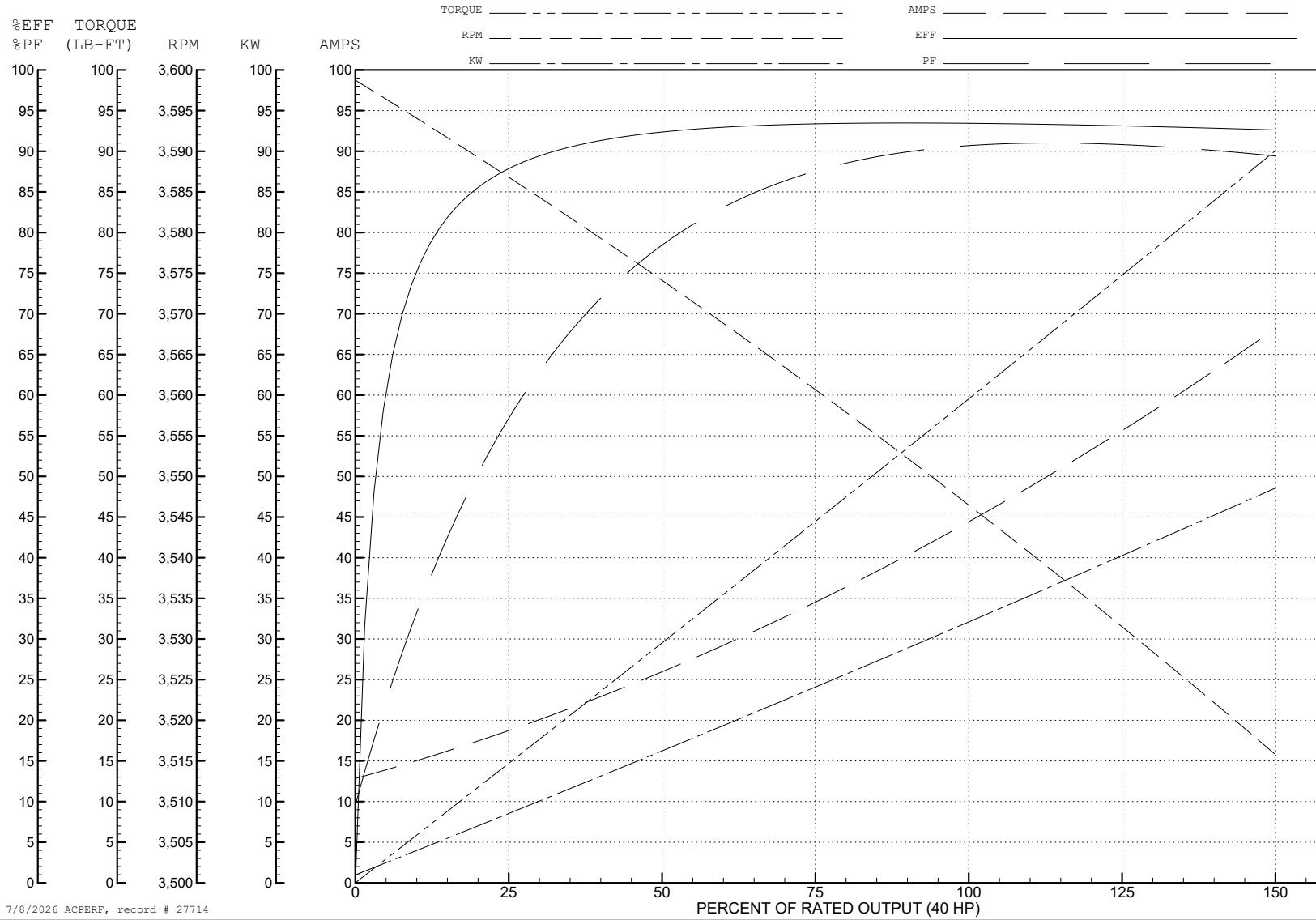

7/8/2026 ACPERF, record # 27714

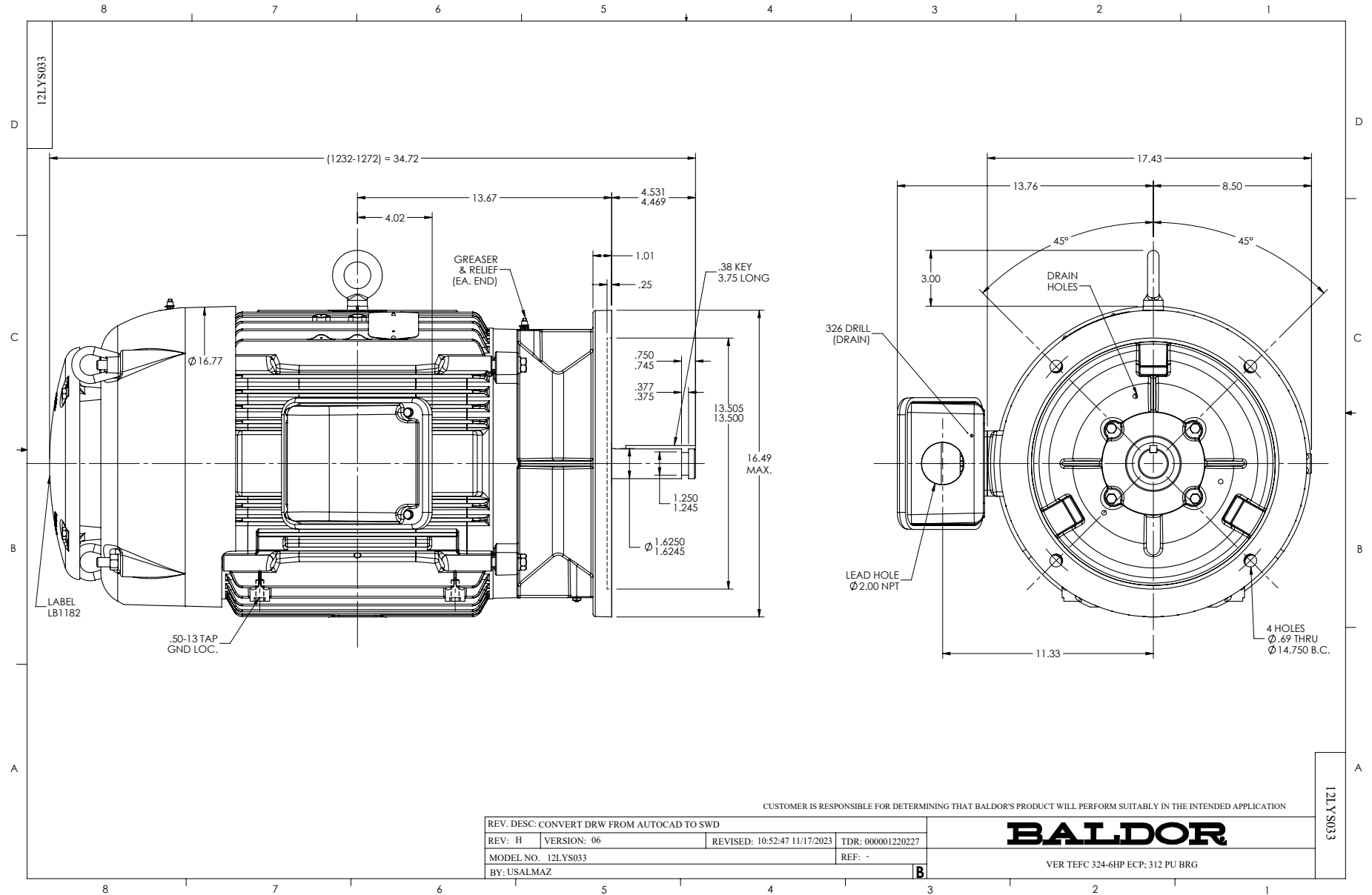

CD0180

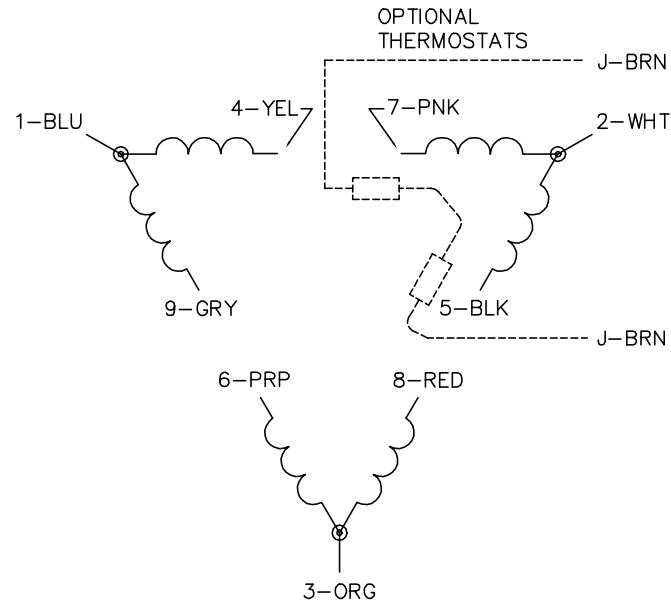

LOW VOLTAGE
(2D)

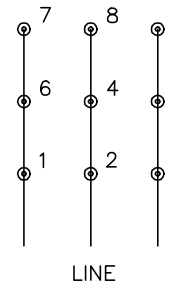

HIGH VOLTAGE
(1D)

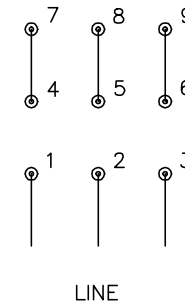

NOTES:

1. INTERCHANGE ANY TWO LINE LEADS TO REVERSE ROTATION.
2. OPTIONAL THERMOSTATS ARE PROVIDED WHEN SPECIFIED.
3. ACTUAL NUMBER OF INTERNAL PARALLEL CIRCUITS MAY BE A MULTIPLE OF THOSE SHOWN ABOVE.
4. LEAD COLORS ARE OPTIONAL. LEADS MUST ALWAYS BE NUMBERED AS SHOWN.

CD0180

REV. DESC: ADD CLASS CONN00000007		
REV. LTR: D	VERSION: 01	TDR: 000001099922
FILE: \AAA\00005\148	REVISED: 10: 25: 29 02/19/2019	BY: ENBRIRO
MTL: -	© □	

BALDOR - RELIANCE®

3PH, DV, 9 LEADS, DELTA CONNECTION

SH 1 of 1