



---

# Customer information packet

## VFSWDNM3558-E

2HP, 1760RPM, 3PH, 60HZ, 56C, 3546M, TENV, F1, N

Class - None

Division - Not Applicable

## Specifications

Enclosure	TENV
Frame	56C
Frame Material	Stainless Steel
Frequency	60.00 Hz
Haz Area Class and Group	None
Haz Area Division	Not Applicable
Motor Letter Type	Three Phase
Output @ Frequency	2.000 HP @ 60 HZ
Phase	3
Synchronous Speed @ Frequency	1800 RPM @ 60 HZ
Voltage @ Frequency	460.0 V @ 60 HZ 230.0 V @ 60 HZ
Agency Approvals	CSA EEV CURUSEEV NEMA PREMIUM NEMA_PREMIUM WEEE
Ambient Temperature	40 °C
Auxillary Box	No Auxillary Box
Auxillary Box Lead Termination	None
Base Indicator	No Mounting
Bearing Grease Type	Polyrex EM (-20F +300F)
Blower	None
Current @ Voltage	5.600 A @ 208.0 V 5.300 A @ 230.0 V 2.650 A @ 460.0 V
Design Code	B
Drip Cover	No Drip Cover
Duty Rating	CONT
Efficiency @ 100% Load	86.5 %
Electrically Isolated Bearing	Not Electrically Isolated
Feedback Device	NO FEEDBACK

## Part detail

Revision	D
Type	AC
Mech. spec.	35E4656
Base	
Status	PRD/A
Elec. spec.	35WGZ811
Layout	35LYE4656
Eff. date	08-14-2023
CD Diagram	CD0005
Poles	04
Leads	9#18
Proprietary	False
Created date	03-11-2022

Front Shaft Indicator	None
Heater Indicator	No Heater
High Voltage Full Load Amps	2.7 a
Insulation Class	H
Inverter Code	Inverter Duty
KVA Code	L
Lifting Lugs	No Lifting Lugs
Locked Bearing Indicator	Locked Bearing
Max Speed	2700 rpm
Motor Finish	UNPAINTED
Motor Lead Quantity/Wire Size	9 @ 18 AWG
Motor Lead Termination	Flying Leads
Motor Standards	NEMA
Motor Type	3546M
Mounting Arrangement	F1
Number of Poles	4
Overall Length	15.04 IN
Power Factor	80
Product Family	WD All SS Encapsulated
Pulley End Bearing Type	Sealed Bearing
Pulley Face Code	C-Face
Pulley Shaft Indicator	Standard
Rodent Screen	None
Service Factor	1.15
Shaft Diameter	0.625 IN
Shaft Ground Indicator	No Shaft Grounding
Shaft Rotation	Reversible
Shaft Slinger Indicator	No Slinger
Speed	1760 rpm
Speed Code	Single Speed
Starting Method	Direct on line
Thermal Device - Bearing	None
Thermal Device - Winding	None
Vibration Sensor Indicator	No Vibration Sensor

Winding Thermal 1

None

---

Winding Thermal 2

None

---



**AC Induction Motor Performance Data**

Record # 87105

Preliminary Data Sheet

<b>Winding:</b> 35WGZ811-R001		<b>Type:</b> 3546M		<b>Enclosure:</b> TENV	
<b>Nameplate Data</b>			<b>460 V, 60 Hz: High Voltage Connection</b>		
<b>Rated Output (HP)</b>	2	<b>Full Load Torque</b>	6 LB-FT		
<b>Volts</b>	230/460	<b>Start Configuration</b>	direct on line		
<b>Full Load Amps</b>	5.3/2.65	<b>Breakdown Torque</b>	27.78 LB-FT		
<b>R.P.M.</b>	1760	<b>Pull-up Torque</b>	16.81 LB-FT		
<b>Hz</b>	60 <b>Phase</b>	3	<b>Locked-rotor Torque</b>	21.79 LB-FT	
<b>NEMA Design Code</b>	<b>B KVA Code</b>	L	<b>Starting Current</b>	25.07 A	
<b>Service Factor (S.F.)</b>	1.15	<b>No-load Current</b>	1.36 A		
<b>NEMA Nom. Eff.</b>	86.5 <b>Power Factor</b>	80	<b>Line-line Res. @ 25°C</b>	7.86 Ω	
<b>Rating - Duty</b>	40C AMB-CONT	<b>Temp. Rise @ Rated Load</b>	100°C		
<b>S.F. Amps</b>	6/3	<b>Temp. Rise @ S.F. Load</b>	122°C		
		<b>Locked-rotor Power Factor</b>	51.7		
		<b>Rotor inertia</b>	0.332 lb-ft <sup>2</sup>		

**Load Characteristics 460 V, 60 Hz, 2 HP**

<b>% of Rated Load</b>	<b>25</b>	<b>50</b>	<b>75</b>	<b>100</b>	<b>125</b>	<b>150</b>	<b>S.F.</b>
<b>Power Factor</b>	39	61	73	80	85	87	83
<b>Efficiency</b>	83.3	88.6	89.2	88.7	87.5	86	88
<b>Speed</b>	1790	1781	1771	1760	1748	1735	1753
<b>Line amperes</b>	1.5	1.78	2.17	2.65	3.18	3.77	2.97

ABB Motors and Mechanical Inc.

WINDING # 35WGZ811

Typical performance - not guaranteed values.

2 HP 3 PH 60 HZ 1760 RPM 460 V 3546M

TORQUES (LB-FT): PO=27.78 PU=16.81 LR=21.79 LRA=25.07

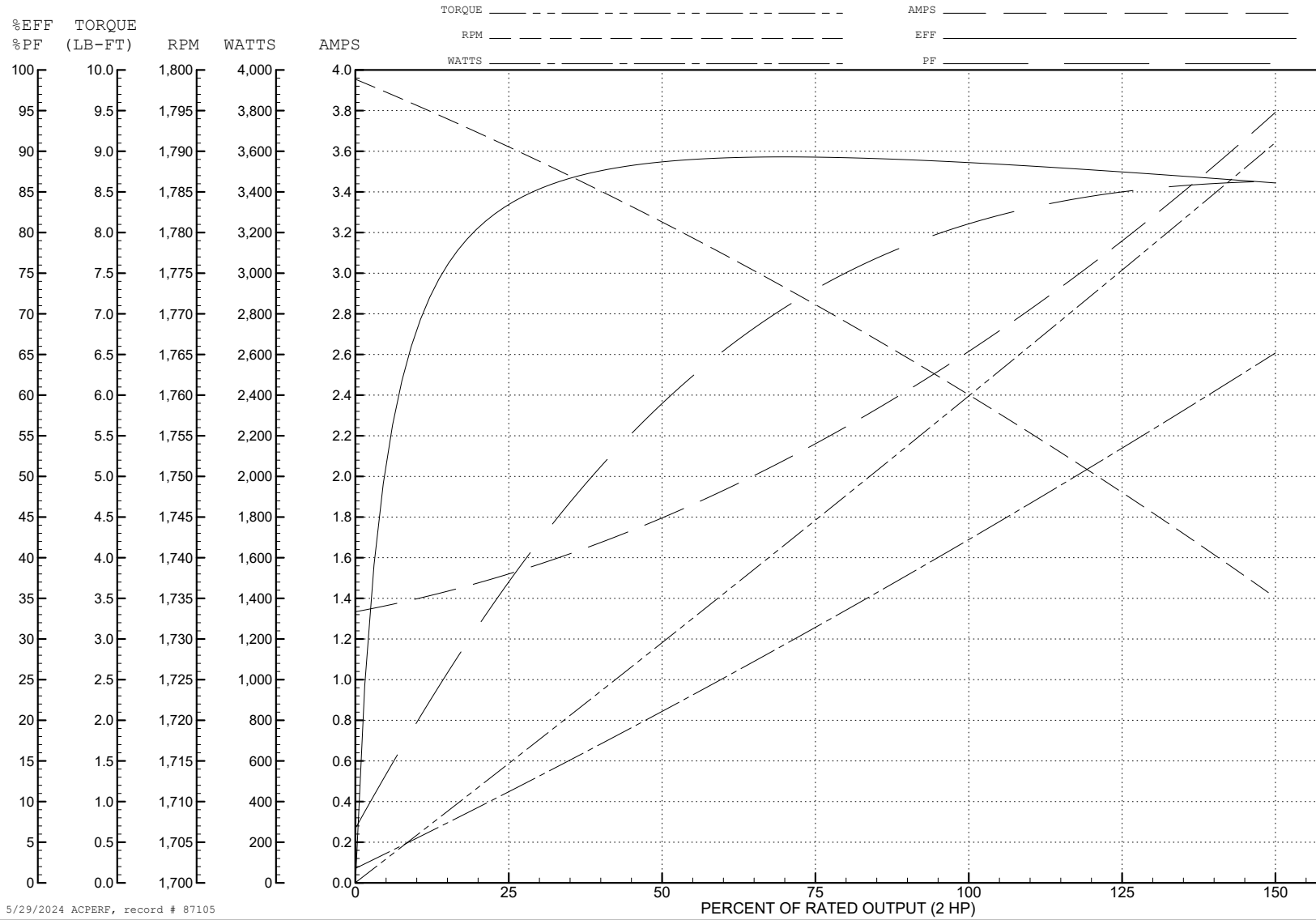

5/29/2024 ACPERF, record # 87105

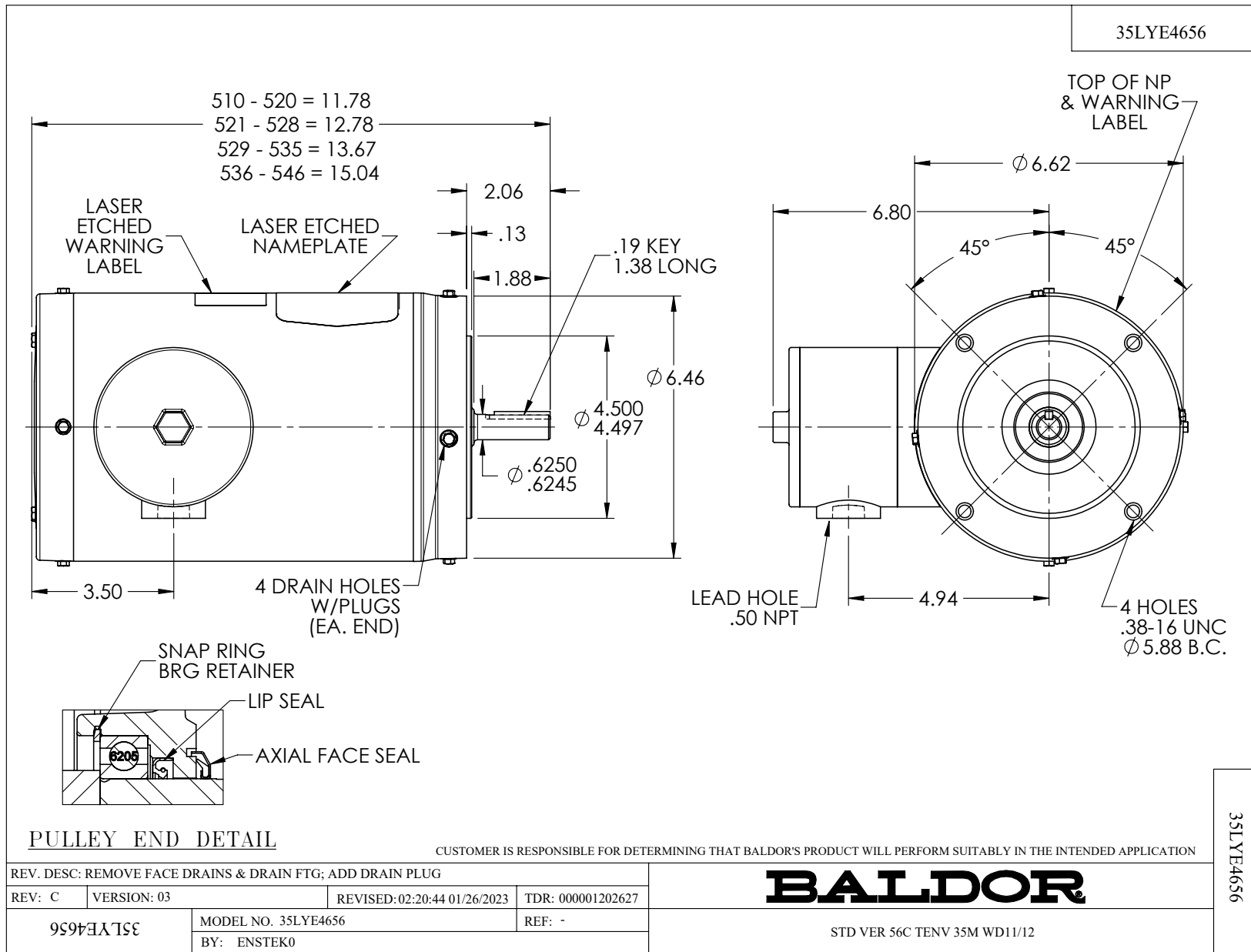



CD0005

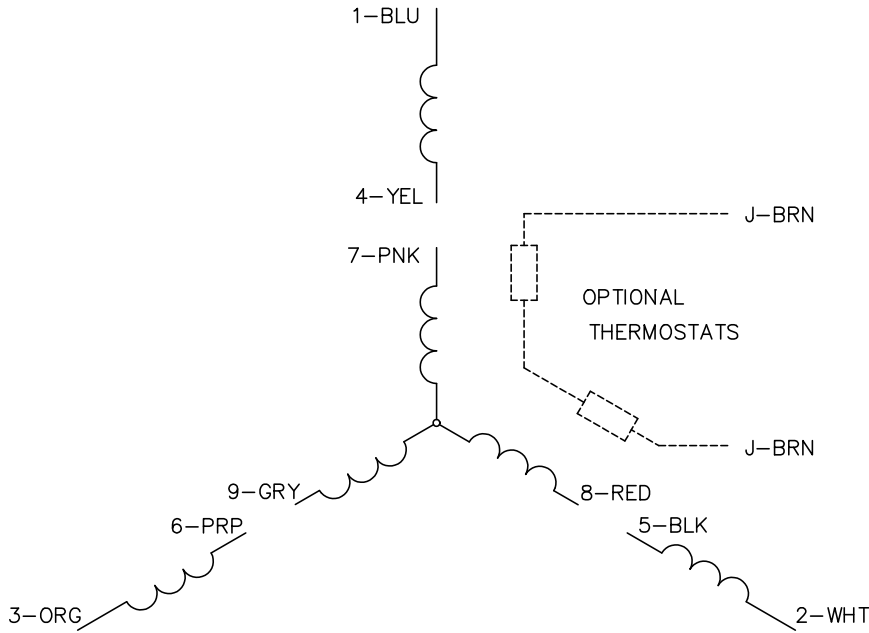

LOW VOLTAGE  
(2Y)

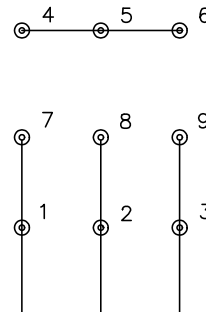

LINE

HIGH VOLTAGE  
(1Y)

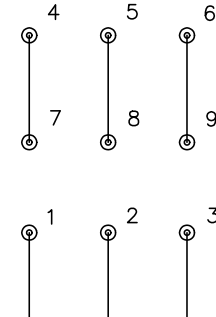

LINE

NOTES:

1. INTERCHANGE ANY TWO LINE LEADS TO REVERSE ROTATION.
2. OPTIONAL THERMOSTATS ARE PROVIDED WHEN SPECIFIED.
3. ACTUAL NUMBER OF INTERNAL PARALLEL CIRCUITS MAY BE A MULTIPLE OF THOSE SHOWN ABOVE.
4. LEAD COLORS ARE OPTIONAL. LEADS MUST ALWAYS BE NUMBERED AS SHOWN.

CD0005

REV. DESC: REVISE TO SHOW OPTIONAL COLORS

REV. LTR: E BY: JLP REVISED: 01/19/99 10:15 TDR: 0171435

500000

FILE: AAA00005140

MDL: -

MTL: -

**BALDOR ELECTRIC Co.**

3PH, DV, 9 LEADS