



Customer information packet

VFSWDL3507

.75HP, 1745RPM, 1PH, 60HZ, 56C, 3530L, TEFC, F1

Class - None

Division - Not Applicable

Specifications

Enclosure	TEFC
Frame	56C
Frame Material	Stainless Steel
Frequency	60.00 Hz
Motor Letter Type	Cap Start, Induction Run
Output @ Frequency	.750 HP @ 60 HZ
Phase	1
Synchronous Speed @ Frequency	1800 RPM @ 60 HZ
Voltage @ Frequency	115.0 V @ 60 HZ 230.0 V @ 60 HZ
XP Class and Group	None
XP Division	Not Applicable
Agency Approvals	WEEE C UR US
Ambient Temperature	40 °C
Auxillary Box	No Auxillary Box
Auxillary Box Lead Termination	None
Base Indicator	No Mounting
Bearing Grease Type	Polyrex EM (-20F +300F)
Blower	None
Current @ Voltage	4.100 A @ 230.0 V 8.200 A @ 115.0 V
Design Code	N
Drip Cover	No Drip Cover
Duty Rating	CONT
Efficiency @ 100% Load	74.0 %
Electrically Isolated Bearing	Not Electrically Isolated
Feedback Device	NO FEEDBACK
Front Shaft Indicator	None
Heater Indicator	No Heater
High Voltage Full Load Amps	4.1 a
Insulation Class	F

Part detail

Revision	A
Type	AC
Mech. spec.	35E4628
Base	
Status	PRD/A
Elec. spec.	35WGG409
Layout	35LYE4628
Eff. date	11-08-2023
CD Diagram	CD0648
Poles	04
Leads	7#18
Proprietary	False
Created date	02-23-2023

Inverter Code	Not Inverter
KVA Code	K
Lifting Lugs	No Lifting Lugs
Locked Bearing Indicator	Locked Bearing
Motor Finish	UNPAINTED
Motor Lead Quantity/Wire Size	7 @ 18 AWG
Motor Lead Termination	Flying Leads
Motor Standards	NEMA
Motor Type	3530L
Mounting Arrangement	F1
Number of Poles	4
Overall Length	14.83 IN
Power Factor	78
Product Family	WD All SD Non-Encapsulated
Pulley End Bearing Type	Sealed Bearing
Pulley Face Code	C-Face
Pulley Shaft Indicator	Standard
Rodent Screen	None
RoHS Status	ROHS COMPLIANT
Service Factor	1.15
Shaft Diameter	0.625 IN
Shaft Ground Indicator	No Shaft Grounding
Shaft Rotation	Reversible
Shaft Slinger Indicator	No Slinger
Speed	1745 rpm
Speed Code	Single Speed
Starting Method	Direct on line
Thermal Device - Bearing	None
Thermal Device - Winding	None
Vibration Sensor Indicator	No Vibration Sensor
Winding Thermal 1	None
Winding Thermal 2	None

AC Induction Motor Performance Data

Record # 89159

Typical performance - not guaranteed values

Winding: 35WGG409-R001		Type: 3530L	Enclosure: TEFC	
Nameplate Data			115 V, 60 Hz: Low Voltage Connection	
Rated Output (HP)	.75	Full Load Torque	2.23 LB-FT	
Volts	115/230	Start Configuration	direct on line	
Full Load Amps	8.2/4.1	Breakdown Torque	5.29 LB-FT	
R.P.M.	1745	Pull-up Torque	3.99 LB-FT	
Hz	60 Phase	1	Locked-rotor Torque	8.9 LB-FT
NEMA Design Code	N KVA Code	K	Starting Current	51.11 A
Service Factor (S.F.)	1.25	No-load Current	4.46 A	
NEMA Nom. Eff.	74 Power Factor	78	Line-line Res. @ 25°C	0.917 Ω A Ph 1.84 Ω B Ph
Rating - Duty	40C AMB-CONT	Temp. Rise @ Rated Load		
S.F. Amps	9.9/4.95	Temp. Rise @ S.F. Load		
		Locked-rotor Power Factor	95.6	
		Rotor inertia	0.217 lb-ft ²	

Load Characteristics 115 V, 60 Hz, 0.75 HP

% of Rated Load	25	50	75	100	125	150	S.F.
Power Factor	41	59	71	77	82	85	82
Efficiency	61.6	73	75.5	75.4	73.4	70.2	73.4
Speed	1786	1773	1759	1744	1726	1702	1726
Line amperes	4.81	5.65	6.82	8.22	9.88	11.8	9.88

ABB Motors and Mechanical Inc.

WINDING # 35WGG409

Typical performance - not guaranteed values.

0.75 HP 1 PH 60 HZ 1745 RPM 115 V 3530L

TORQUES (LB-FT): PO=5.29 PU=3.99 LR=8.9 LRA=51.11

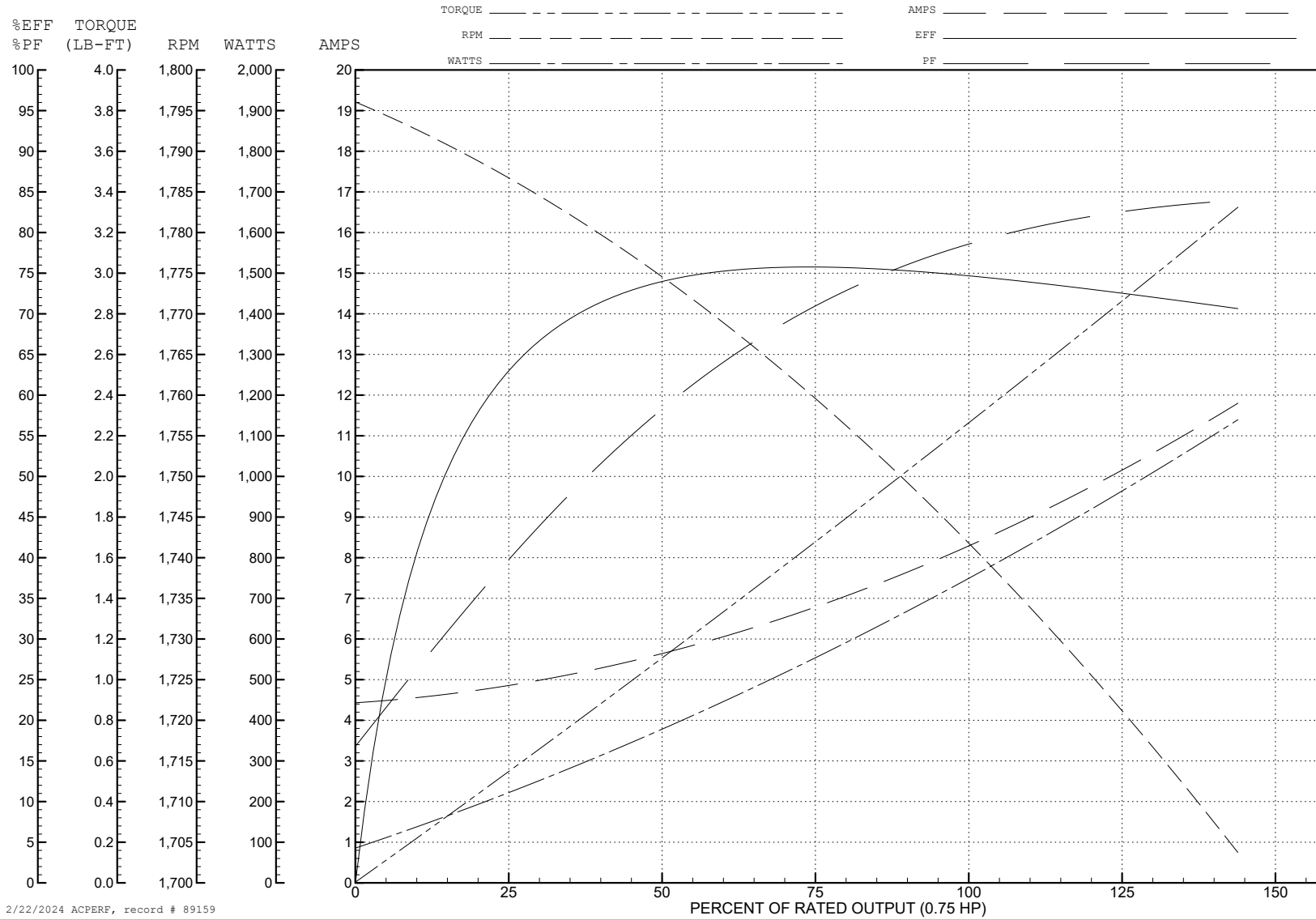

2/22/2024 ACPERF, record # 89159

35LYE4628

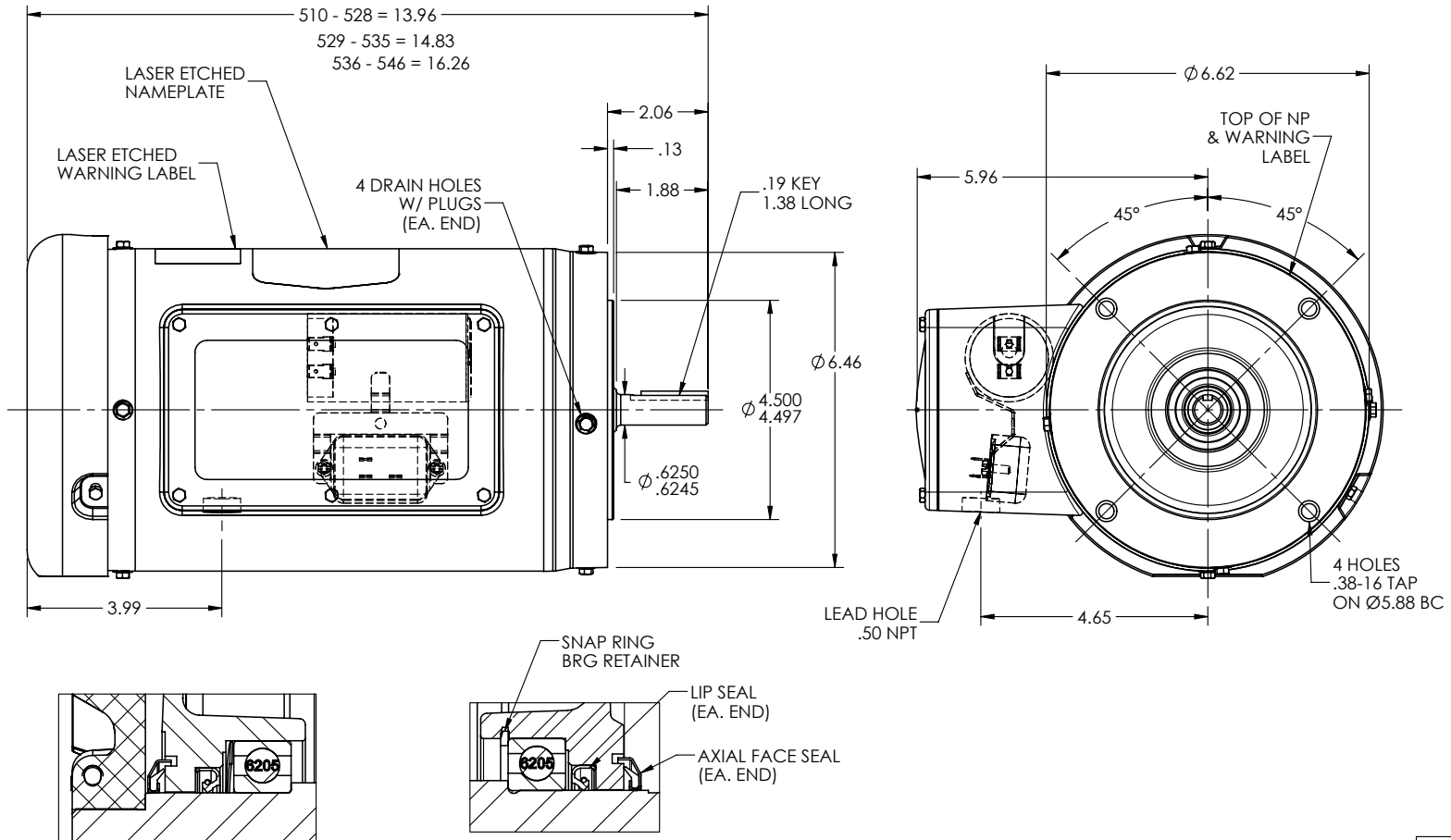

FRONT END DETAIL

PULLEY END DETAIL

CUSTOMER IS RESPONSIBLE FOR DETERMINING THAT BALDOR'S PRODUCT WILL PERFORM SUITABLY IN THE INTENDED APPLICATION

REV. DESC: REMOVE FACE DRAINS & DRAIN FTG; ADD DRAIN PLUG

REV: A	VERSION: 01	REVISED: 09:14:42 01/26/2023	TDR: 000001202627
--------	-------------	------------------------------	-------------------

35LYE4628

MODEL NO. 35LYE4628

BY: ENSTEK0

REF: -

BALDOR

STD VER 56C TEFC 35L WD11/12

35LYE4628

CD0648

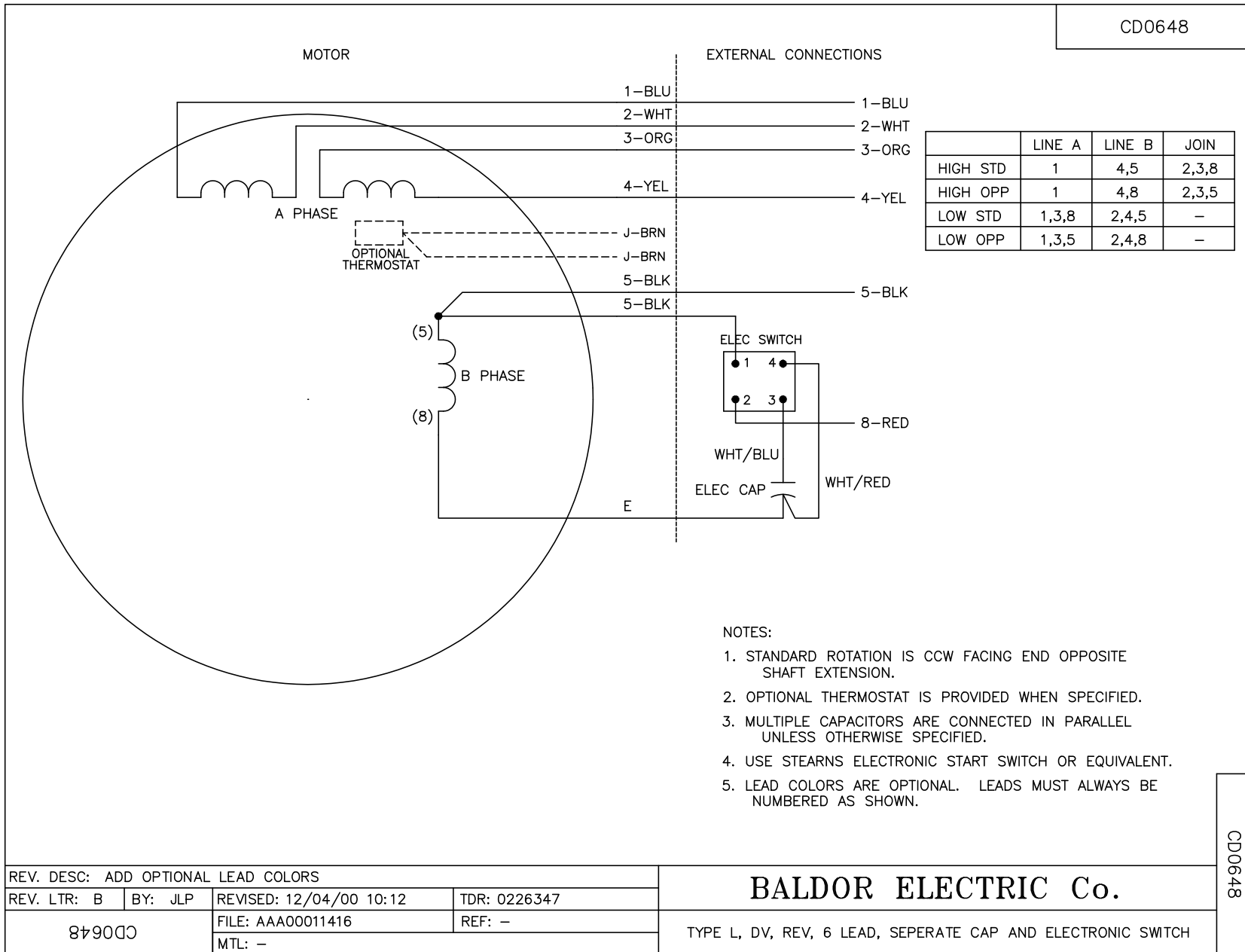

CD0648

REV. DESC: ADD OPTIONAL LEAD COLORS			
REV. LTR: B	BY: JLP	REVISED: 12/04/00 10:12	TDR: 0226347
879000		FILE: AAA00011416	REF: -
		MTL: -	

BALDOR ELECTRIC Co.

TYPE L, DV, REV, 6 LEAD, SEPERATE CAP AND ELECTRONIC SWITCH