

8 7 6 5 4 3 2 1

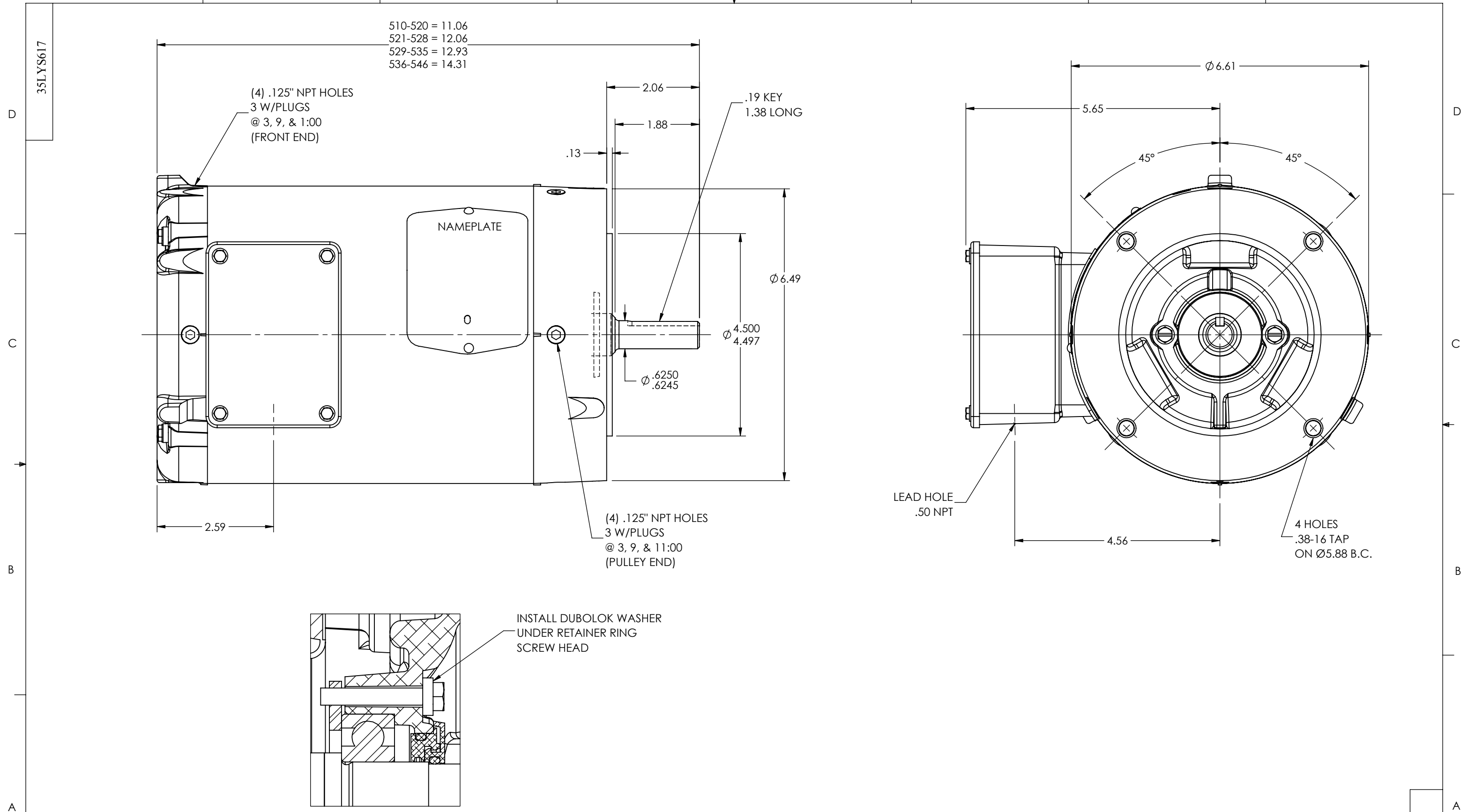

CUSTOMER IS RESPONSIBLE FOR DETERMINING THAT THE PRODUCT WILL PERFORM SUITABLY IN THE INTENDED APPLICATION

REV. DESC: LOADING OF SWD DWG FOR 2D TO 3D CONVERSION - PKG12			
REV: D	VERSION: 04	REVISED: 07:53:24 12/12/2018	TDR: 000001093440
MODEL NO. 35LYS617			REF: -
BY: ENALEM0			B

BALDOR - RELIANCE®

VERT 56C TENV 35M WD2 (PAINT FREE)
 SH 1 of 1

A 35LYS617

8 7 6 5 4 3 2 1