

8 7 6 5 4 3 2 1

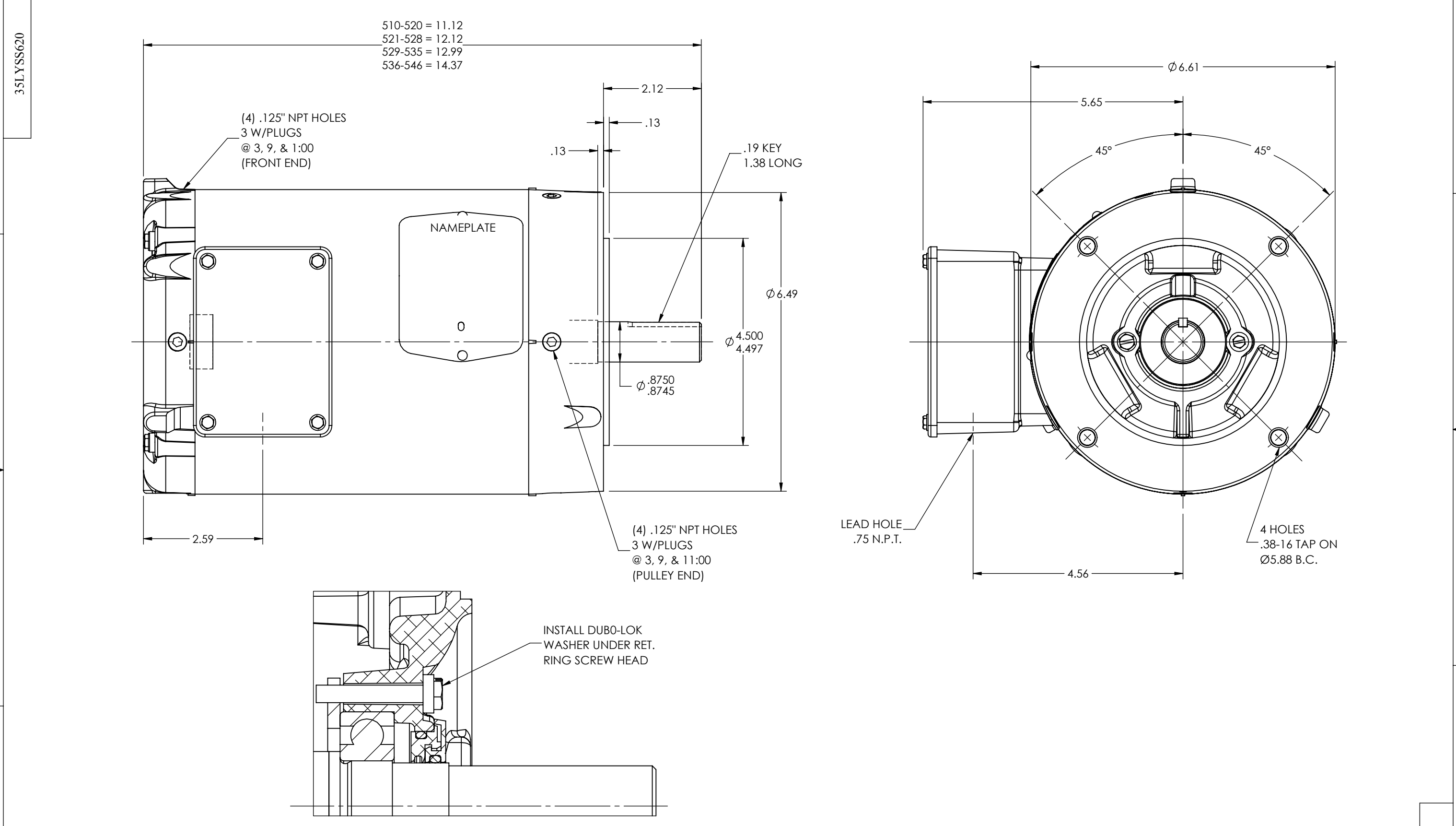

CUSTOMER IS RESPONSIBLE FOR DETERMINING THAT THE PRODUCT WILL PERFORM SUITABLY IN THE INTENDED APPLICATION

REV. DESC: LOADING OF SWD DWG FOR 2D TO 3D CONVERSION PKG 15			
REV: C	VERSION: 03	REVISED: 01:27:24 01/21/2019	TDR: 000001096905
MODEL NO. 35LYSS620		REF: -	
BY: ENALEM0		B	

BALDOR - RELIANCE®

VERT 143-5TC TENV 35M WD2 (PAINT FREE) W/.75 NOT LEAD HOLE
SH 1 of 1

8 7 6 5 4 3 2 1

35LYSS620