

ABB BALDOR RELIANCE III

Customer information packet

VEJMM3710T-5

7.5HP, 1770RPM, 3PH, 60HZ, 213JM, 3738M, TEFC

Class - None

Division - Not Applicable

Specifications

Enclosure	TEFC
Frame	213JM
Frame Material	Steel
Frequency	60.00 Hz
Haz Area Class and Group	None
Haz Area Division	Not Applicable
Motor Letter Type	Three Phase
Output @ Frequency	7.500 HP @ 60 HZ
Phase	3
Synchronous Speed @ Frequency	1800 RPM @ 60 HZ
Voltage @ Frequency	575.0 V @ 60 HZ
Agency Approvals	CSA EEV CSA UR
Ambient Temperature	40 °C
Auxiliary Box	NO AUXILLARY BOX
Auxiliary Box Lead Termination	None
Base Indicator	No Mounting
Bearing Grease Type	Polyrex EM (-20F +300F)
Blower	None
Current @ Voltage	7.600 A @ 575.0 V
Design Code	A
Drip Cover	No Drip Cover
Duty Rating	CONT
Efficiency @ 100% Load	91.7 %
Electrically Isolated Bearing	Not Electrically Isolated
Feedback Device	NO FEEDBACK
Front Face Code	Standard
Front Shaft Indicator	None
Heater Indicator	No Heater
High Voltage Full Load Amps	7.6 a
Insulation Class	F

Part Detail

Revision	G
Type	AC
Mech. spec.	37J787
Base	
Status	PRD/A
Elec. spec.	37WGR907
Layout	37LYJ787
Eff. date	05-02-2024
CD Diagram	CD0006
Poles	04
Leads	3#14
Proprietary	False
Created date	12-07-2015

Inverter Code	Inverter Ready
KVA Code	J
Lifting Lugs	Standard Lifting Lugs
Locked Bearing Indicator	Locked Bearing
Motor Lead Exit	Ko Box
Motor Lead Quantity/Wire Size	3 @ 14 AWG
Motor Lead Termination	Flying Leads
Motor Standards	NEMA
Motor Type	3738M
Mounting Arrangement	F1
Number of Poles	4
Overall Length	20.89 IN
Power Factor	82
Product Family	General Purpose
Pulley End Bearing Type	Ball
Pulley Face Code	C-Face
Pulley Shaft Indicator	Tapped & Key
Rodent Screen	None
RoHS Status	ROHS COMPLIANT
Service Factor	1.15
Shaft Diameter	0.875 IN
Shaft Extension Location	Pulley End
Shaft Ground Indicator	No Shaft Grounding
Shaft Rotation	Reversible
Shaft Slinger Indicator	Shaft Slinger
Speed	1770 rpm
Speed Code	Single Speed
Starting Method	Direct on line
Thermal Device - Bearing	None
Thermal Device - Winding	None
Vibration Sensor Indicator	No Vibration Sensor
Winding Thermal 1	None
Winding Thermal 2	None

Nameplate

NP3441L									
CAT.NO.	VEJMM3710T-5								
SPEC.	37J787R907G1								
HP	7.5								
VOLTS	575								
AMP	7.6								
RPM	1770								
FRAME	213JM		HZ	60			PH	3	
SER.F.	1.15	CODE	J	DES	A	CL	F		
NEMA-NOM-EFF	91.7	PF	82						
RATING	40C AMB-CONT								
CC	010A								
DE	6309	ODE	6206						
ENCL	TEFC	SN							
VPWM INVERTER READY									
CT6-60H(10:1)VT3-60H(20:1)									

ABB Motors and Mechanical Inc.

WINDING # 37WGR907

Typical performance - not guaranteed values.

7.5 HP 3 PH 60 HZ 1770 RPM 575 V 3738M

TORQUES (LB-FT): PO=71 PU=32.6 LR=43 LRA=56.9

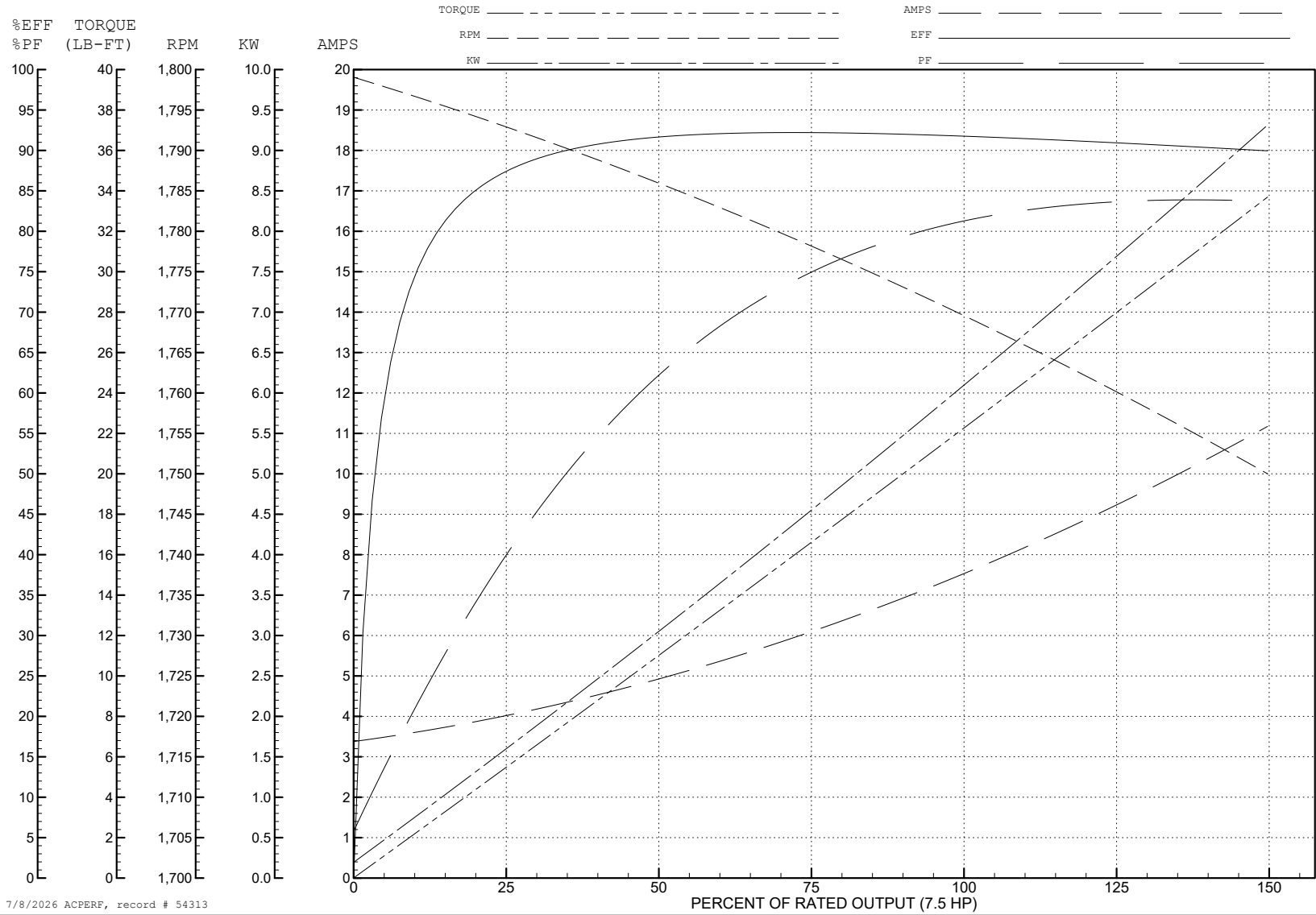

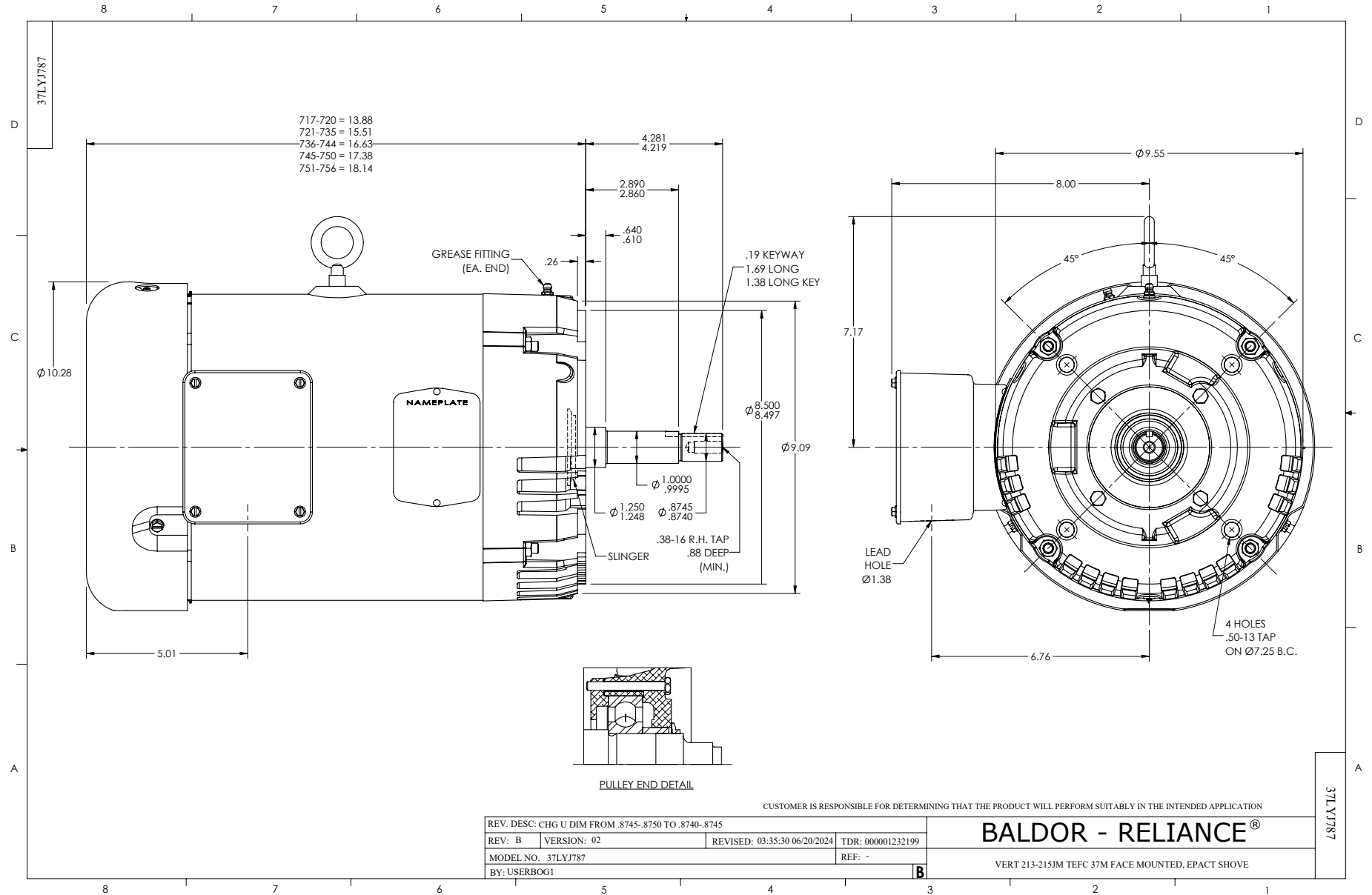

CD0006



NOTES:

1. THREE LEAD MOTOR MAY BE EITHER WYE CONNECTED OR DELTA CONNECTED.
2. INTERCHANGE ANY TWO LINE LEADS TO REVERSE ROTATION.
3. OPTIONAL THERMOSTATS ARE PROVIDED WHEN SPECIFIED.
4. ACTUAL NUMBER OF INTERNAL PARALLEL CIRCUITS MAY VARY.
5. LEAD COLORS ARE OPTIONAL. LEADS MUST BE NUMBERED AS SHOWN.

CD0006

REV. DESC: ADD CLASS CONN00000007		
REV. LTR: E	VERSION: 01	TDR: 000001099922
FILE: \AAA\00005\141	REVISED: 10:24:49 02/19/2019	BY: ENBRIRO
MTL: -	© □	

BALDOR - RELIANCE®

3PH, SV, 3 LEADS, WYE OR DELTA CONNECTED

SH 1 of 1