

BALDOR® • RELIANCE®

Customer information packet

SSBSM80C-175CA

8 LB. IN. , SS BSM SERVO MOTOR

Specifications

Enclosure	TENV
Nameplate Speed	4000
Agency Approvals	C UR US CE
Base Indicator	Bracket Mounted
Dimensional Drawing Numbers	S2LYP263
Frame	D100D
Frame Material	Exposed Laminations
Motor Lead Quantity/Wire Size	3 @ 18 AWG
Motor Standards	IEC
Mounting Arrangement	F1
Nameplate Output	0.26KW
Shaft Rotation	Reversible

Part detail

Revision	AA
Type	AC
Mech. spec.	S2P263
Base	
Status	PRD/A
Elec. spec.	S2WGW050
Layout	S2LYP263
Eff. date	05-21-2022
CD Diagram	CD0006A02
Poles	04
Leads	3#18
Proprietary	False
Created date	01-01-0001

Nameplate

NP4320			
CAT.NO.	SSBSM80C-175CA		
BLANK	IP67 IC410 7KG		
SPEC.	S2P263W050		
MFG.NO.			
TORQ CONT STALL	0.96 NM		
CUR CONT STALL/A RMS	1.54		
POWER	0.26KW		
RATED SPEED/RPM	4000		
RATED BUS VOLTS	300		
PEAK CUR/A RMS	3.93		
MAX SPEED/RPM	7000		
CLASS	F	AMB.	25
APRV-CE			

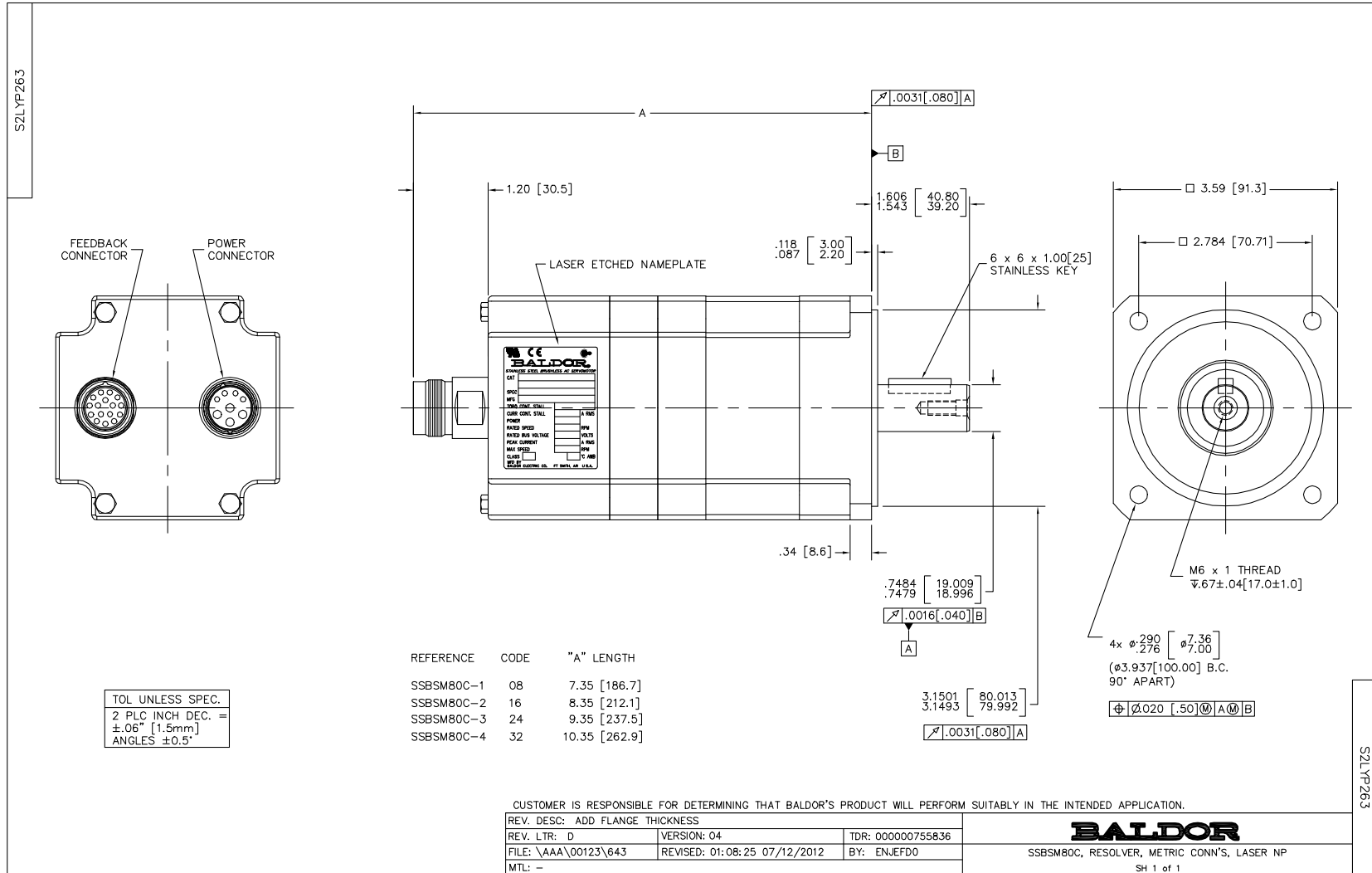

CD0006A02

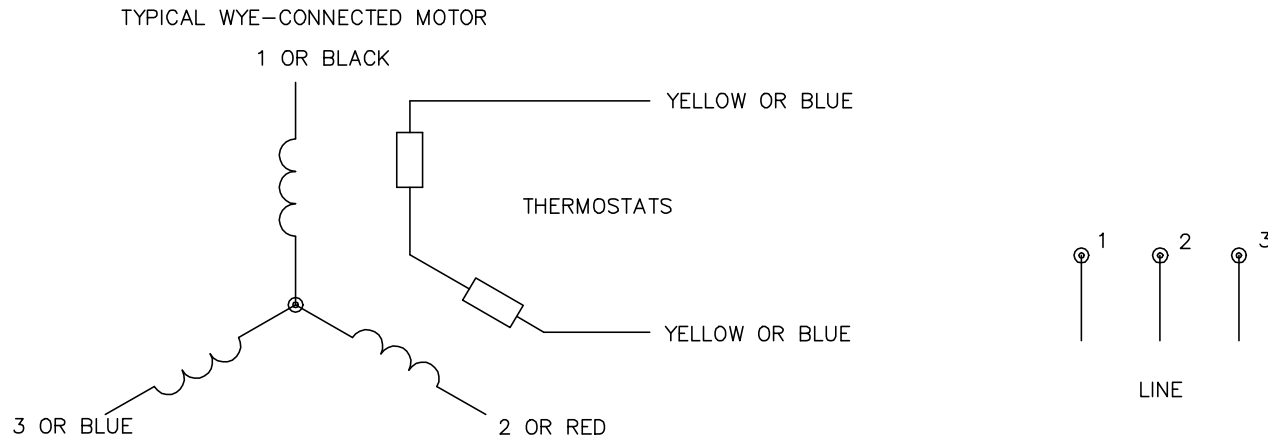

NOTES:

1. INTERCHANGE ANY TWO LINE LEADS TO REVERSE ROTATION.
2. ACTUAL NUMBER OF INTERNAL PARALLEL CIRCUITS MAY VARY.

REV. DESC: REMOVED "OPTIONAL" FROM PRINT, SERVO REQ'S T'STATS		
REV. LTR: D	VERSION: 03	TDR: 000000414937
CD0006A02	FILE: \AAA\00068\606	REVISED: 10:02:28 11/21/2006
	MTL: -	BY: ENJEFO

BALDOR ELECTRIC Co.

3PH, SV, 3 LEADS, WYE CONNECTED

CD0006A02

CD1808

8 PIN THREADED CONNECTOR
(CRIMP STYLE)
(INSERTION SIDE)

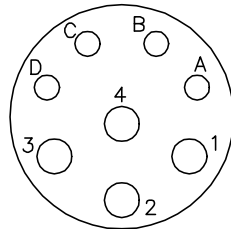

MOTOR CONNECTIONS

PIN	FUNCTION	INTERNAL WIRE COLOR
A	THERMAL SWITCH *	YELLOW
B	THERMAL SWITCH *	YELLOW
C	BRAKE *	BLACK (* RED)
D	BRAKE *	BLACK
1	U	BLACK OR T1
2	GROUND	GREEN OR **GREEN/YELLOW
3	W	BLUE OR T3
4	V	RED OR T2

* WHEN REQUIRED

**CE MOTORS REQUIRE GREEN/YELLOW GROUND

12 PIN THREADED CONNECTOR
(CRIMP STYLE)
(INSERTION SIDE)

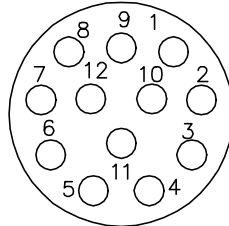

RESOLVER CONNECTIONS

PIN	FUNCTION	INTERNAL WIRE COLOR
1	REF HI R1	RED/WHITE
2	REF LO R2	YELLOW/WHITE
3	COS+ S1	RED
4	COS- S3	BLACK
5	SINE+ S2	BLUE
6	SINE- S4	YELLOW
7	-	-
8	-	-
9	-	-
10	-	-
11	-	-
12	-	-

CD1808

REV. DESC: ADD CE NOTE AND GREEN/YELLOW GROUND

REV. LTR: B

VERSION: 02

TDR: 000001192301

FILE: \AAA\00117\633

REVISED: 02:38:03 06/13/2022

BY: ENDAND0

MTL: -



BALDOR - RELIANCE®

SSBSM - WIRING DIAG, POWER & RESOLVER, 8 & 12 PIN CONN'S

SH 1 of 1