

# ABB BALDOR RELIANCE III

---

## Customer information packet L3352

.13HP, 3450RPM, 1PH, 60HZ, 42, 3310L, TEFC, F1

**Specifications**

<b>Enclosure</b>	TEFC
<b>Frame</b>	42
<b>Frame Material</b>	Steel
<b>Frequency</b>	60.00 Hz
<b>Motor Letter Type</b>	Cap Start, Induction Run
<b>Output @ Frequency</b>	.130 HP @ 60 HZ
<b>Phase</b>	1
<b>Synchronous Speed @ Frequency</b>	3600 RPM @ 60 HZ
<b>Voltage @ Frequency</b>	230.0 V @ 60 HZ 115.0 V @ 60 HZ
<b>Agency Approvals</b>	C UR US CURUS
<b>Ambient Temperature</b>	40 °C
<b>Auxiliary Box</b>	NO AUXILLARY BOX
<b>Auxiliary Box Lead Termination</b>	None
<b>Base Indicator</b>	Rigid
<b>Bearing Grease Type</b>	Polyrex EM (-20F +300F)
<b>Blower</b>	None
<b>Current @ Voltage</b>	1.250 A @ 230.0 V 1.600 A @ 208.0 V 2.500 A @ 115.0 V
<b>Design Code</b>	-
<b>Drip Cover</b>	No Drip Cover
<b>Duty Rating</b>	CONT
<b>Efficiency @ 100% Load</b>	45.0 %
<b>Electrically Isolated Bearing</b>	Not Electrically Isolated
<b>Feedback Device</b>	NO FEEDBACK
<b>Feedback Signal</b>	NONE
<b>Front Face Code</b>	Standard
<b>Front Shaft Indicator</b>	None
<b>Heater Indicator</b>	No Heater
<b>High Voltage Full Load Amps</b>	1.3 a

**Part Detail**

<b>Revision</b>	AS
<b>Type</b>	AC
<b>Mech. spec.</b>	33-850
<b>Base</b>	
<b>Status</b>	PRD/A
<b>Elec. spec.</b>	33WG0931
<b>Layout</b>	33LY0850
<b>Eff. date</b>	10-24-2024
<b>CD Diagram</b>	CD0001A10
<b>Poles</b>	02
<b>Leads</b>	6#18
<b>Proprietary</b>	False
<b>Created date</b>	06-25-2007

<b>Insulation Class</b>	B
<b>Inverter Code</b>	Not Inverter
<b>KVA Code</b>	M
<b>Lifting Lugs</b>	No Lifting Lugs
<b>Locked Bearing Indicator</b>	No Locked Bearing
<b>Motor Lead Exit</b>	Ko Box
<b>Motor Lead Quantity/Wire Size</b>	6 @ 18 AWG
<b>Motor Lead Termination</b>	Flying Leads
<b>Motor Standards</b>	NEMA
<b>Motor Type</b>	3310L
<b>Mounting Arrangement</b>	F1
<b>Number of Poles</b>	2
<b>Overall Length</b>	9.56 IN
<b>Power Factor</b>	62
<b>Product Family</b>	General Purpose
<b>Pulley End Bearing Type</b>	Ball
<b>Pulley Face Code</b>	Standard
<b>Pulley Shaft Indicator</b>	Standard
<b>Rodent Screen</b>	None
<b>RoHS Status</b>	ROHS COMPLIANT
<b>Service Factor</b>	1.40
<b>Shaft Diameter</b>	0.375 IN
<b>Shaft Extension Location</b>	Pulley End
<b>Shaft Ground Indicator</b>	No Shaft Grounding
<b>Shaft Rotation</b>	Reversible
<b>Shaft Slinger Indicator</b>	No Slinger
<b>Speed</b>	3450 rpm
<b>Speed Code</b>	Single Speed
<b>Starting Method</b>	Direct on line
<b>Thermal Device - Bearing</b>	None
<b>Thermal Device - Winding</b>	None
<b>Vibration Sensor Indicator</b>	No Vibration Sensor
<b>Winding Thermal 1</b>	None
<b>Winding Thermal 2</b>	None

**Nameplate**

<b>NP1256L</b>									
<b>CAT.NO.</b>	L3352								
<b>SPEC.</b>	33-850-931								
<b>HP</b>	.13								
<b>VOLTS</b>	115/230								
<b>AMP</b>	2.5/1.25								
<b>RPM</b>	3450								
<b>FRAME</b>	42		<b>HZ</b>	60		<b>PH</b>	1		
<b>SER.F.</b>	1.40	<b>CODE</b>	M	<b>DES</b>	-	<b>CLASS</b>	B		
<b>NEMA-NOM-EFF</b>	45	<b>PF</b>	62						
<b>RATING</b>	40C AMB-CONT								
<b>CC</b>									
<b>DE</b>	6203		<b>ODE</b>	6203					
<b>ENCL</b>	TEFC	<b>SN</b>							
	SFA 3/1.5								

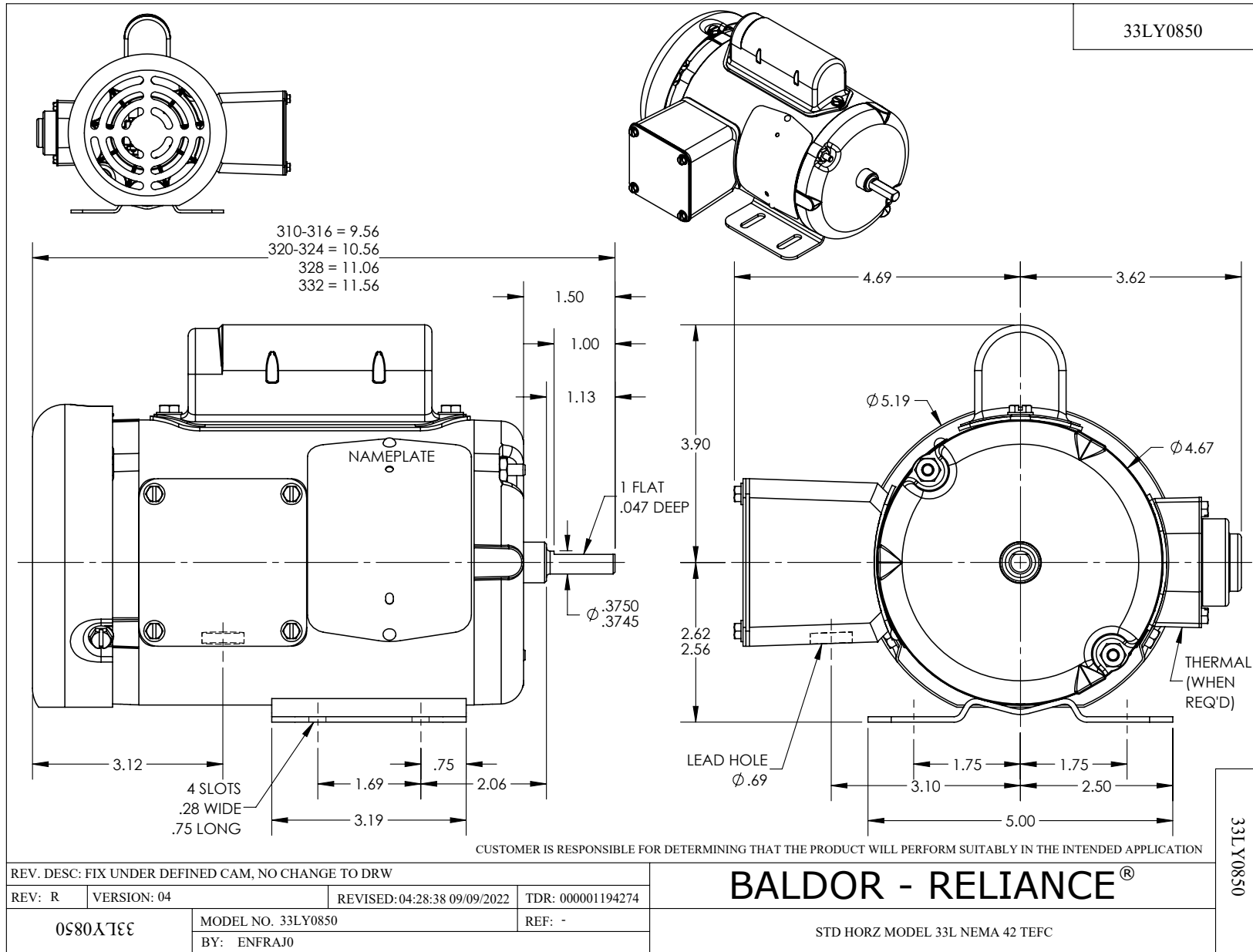

CD0001A10

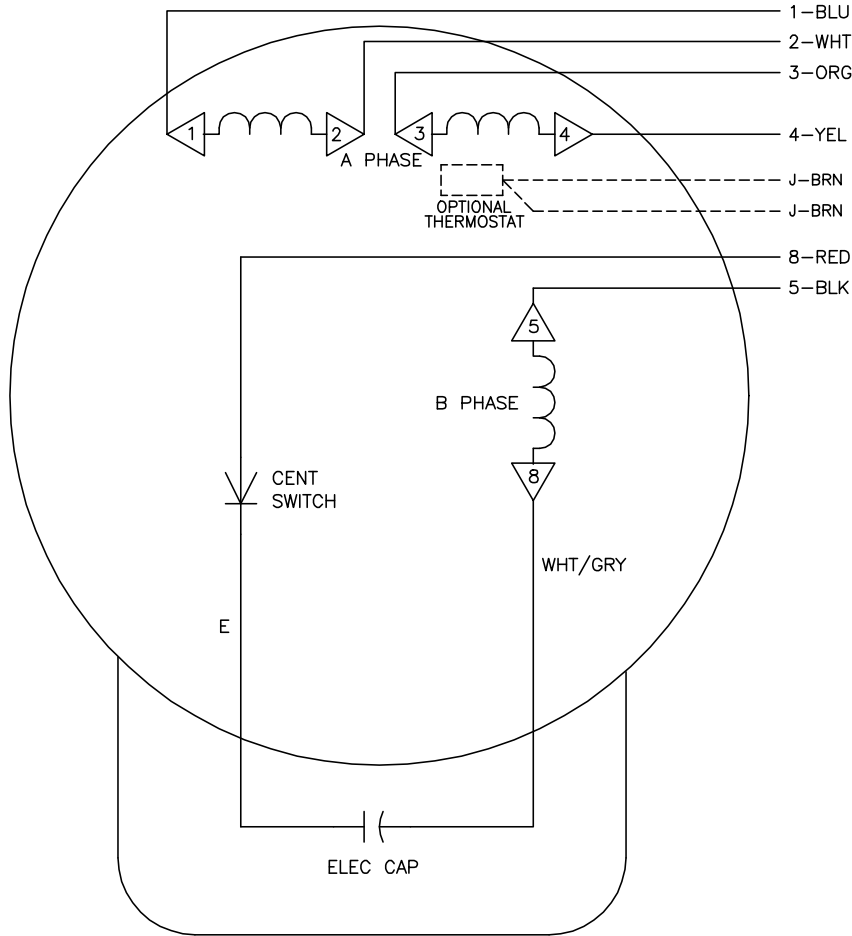

	LINE A	LINE B	JOIN
HIGH STD	1	4,5	2,3,8
HIGH OPP	1	4,8	2,3,5
LOW STD	1,3,8	2,4,5	-
LOW OPP	1,3,5	2,4,8	-

**NOTES:**

1. STANDARD ROTATION IS CCW FACING LEAD END
2. OPTIONAL THERMOSTAT IS PROVIDED WHEN SPECIFIED.
3. MULTIPLE CAPACITORS ARE CONNECTED IN PARALLEL UNLESS OTHERWISE SPECIFIED.
4. LEAD COLORS ARE OPTIONAL. LEADS MUST ALWAYS BE NUMBERED AS SHOWN.
5. = MAGNET WIRE COIL END WITH I.D. NUMBER

REV. DESC: NEW		
REV. LTR: -	VERSION: 00	TDR: 000000435106
01A10000	FILE: \CKA\00032\277	REVISED: 10:15:16 06/19/2007
	MTL: -	BY: CKNTATLO

**Baldor • Dodge • Reliance**

TYPE L, DV, REV, 6 LD, CK

CD0001A10