



---

# Customer information packet

## JMFSWDM3711T-E

10HP, 3500RPM, 3PH, 60HZ, 215JM, 3744M, TEFC, F

Class - None

Division - Not Applicable

## Specifications

Enclosure	TEFC
Frame	215JM
Frame Material	Stainless Steel
Frequency	60.00 Hz
Haz Area Class and Group	None
Haz Area Division	Not Applicable
Motor Letter Type	Three Phase
Output @ Frequency	10.000 HP @ 60 HZ
Phase	3
Synchronous Speed @ Frequency	3600 RPM @ 60 HZ
Voltage @ Frequency	230.0 V @ 60 HZ 460.0 V @ 60 HZ
Agency Approvals	CSA CSA EEV NEMA PREMIUM UR
Ambient Temperature	40 °C
Auxillary Box	No Auxillary Box
Auxillary Box Lead Termination	None
Base Indicator	Rigid
Bearing Grease Type	Polyrex EM (-20F +300F)
Blower	None
Current @ Voltage	23.000 A @ 208.0 V 21.200 A @ 230.0 V 10.600 A @ 460.0 V
Design Code	A
Drip Cover	No Drip Cover
Duty Rating	CONT
Efficiency @ 100% Load	91.7 %
Electrically Isolated Bearing	Not Electrically Isolated
Feedback Device	NO FEEDBACK
Front Face Code	Standard

## Part detail

Revision	R
Type	AC
Mech. spec.	37Q257
Base	
Status	PRD/A
Elec. spec.	37WGS137
Layout	37LYQ257
Eff. date	06-24-2024
CD Diagram	CD0005
Poles	02
Leads	9#14
Proprietary	False
Created date	10-13-2017

Front Shaft Indicator	None
Heater Indicator	No Heater
High Voltage Full Load Amps	10.6 a
Insulation Class	H
Inverter Code	Inverter Ready
KVA Code	L
Lifting Lugs	Standard Lifting Lugs
Locked Bearing Indicator	Locked Bearing
Motor Lead Exit	Ko Box
Motor Lead Quantity/Wire Size	9 @ 14 AWG
Motor Lead Termination	Flying Leads
Motor Standards	NEMA
Motor Type	3744M
Mounting Arrangement	F1
Number of Poles	2
Overall Length	21.81 IN
Power Factor	94
Product Family	WD All SS Encapsulated
Pulley End Bearing Type	Sealed Bearing
Pulley Face Code	C-Face
Pulley Shaft Indicator	Tapped & Key
Rodent Screen	None
RoHS Status	ROHS COMPLIANT
Service Factor	1.15
Shaft Diameter	0.875 IN
Shaft Extension Location	Pulley End
Shaft Ground Indicator	No Shaft Grounding
Shaft Rotation	Reversible
Shaft Slinger Indicator	No Slinger
Speed	3500 rpm
Speed Code	Single Speed
Starting Method	Direct on line
Thermal Device - Bearing	None
Thermal Device - Winding	None

**Vibration Sensor Indicator****No Vibration Sensor****Winding Thermal 1****None****Winding Thermal 2****None**

---

**Nameplate**

<b>NP4427AAA01</b>											
<b>CAT #</b>	JMFSWDM3711T-E				<b>WT</b>	189	<b>LBS</b>				
<b>SPEC</b>	37Q257S137G1				<b>ENCL</b>	TEFC					
<b>SER #</b>					<b>CC</b>	010A	<b>IP</b>	69			
<b>HP</b>	10		<b>MAG CUR</b>	7/3.5							
<b>VOLTS</b>	230/460				<b>NEMA NOM. EFF</b>	91.7					
<b>AMPS</b>	21.2/10.6				<b>PF</b>	94					
<b>RATING</b>	40C AMB-CONT										
<b>RPM</b>	3500				<b>MAX RPM</b>	5400					
<b>FRAME</b>	215JM	<b>HZ</b>	60	<b>CODE</b>	L	<b>CLASS</b>	H				
<b>SER.F.</b>	1.15	<b>SF AMP</b>				<b>PH</b>	3	<b>DES</b>	A		
<b>DE</b>	6309		<b>ODE</b>	6307							
<b>LUBRICATION</b>	POLYREX EM										
<b>ID LOGO</b>	<b>INVERTER TYPE</b>	<b>VPWM</b>		<b>CHP</b>	60	<b>TO</b>	90	1.5:1			
<b>ID LOGO</b>	<b>WK2</b>	0.4	<b>CT</b>	15	<b>TO</b>	60	4:1				
<b>ID LOGO</b>	<b>SL HZ</b>	1.7	<b>VT</b>	6	<b>TO</b>	60	10:1				
					<b>QR</b>						
<b>YR</b>											

**AC Induction Motor Performance Data**

Record # 57389

Typical performance - not guaranteed values

Winding: 37WGS137-R011		Type: 3744M	Enclosure: TEFC
<b>Nameplate Data</b>		<b>460 V, 60 Hz: High Voltage Connection</b>	
Rated Output (HP)	10	Full Load Torque	15 LB-FT
Volts	230/460	Start Configuration	direct on line
Full Load Amps	21.2/10.6	Breakdown Torque	89.4 LB-FT
R.P.M.	3500	Pull-up Torque	39 LB-FT
Hz	60 Phase	Locked-rotor Torque	46.5 LB-FT
NEMA Design Code	A KVA Code	Starting Current	124 A
Service Factor (S.F.)	1.15	No-load Current	4.28 A
NEMA Nom. Eff.	91.7 Power Factor	Line-line Res. @ 25°C	0.659 Ω
Rating - Duty	40C AMB-CONT	Temp. Rise @ Rated Load	67°C
S.F. Amps		Temp. Rise @ S.F. Load	82°C
		Locked-rotor Power Factor	31.5
		Rotor inertia	0.402 LB-FT <sup>2</sup>

**Load Characteristics 460 V, 60 Hz, 10 HP**

% of Rated Load	25	50	75	100	125	150	S.F.
Power Factor	56	77	86	91	91	92	91
Efficiency	81.8	88.7	90.2	91	90.1	89.7	90.5
Speed	3579	3557	3535	3510	3486	3459	3496
Line amperes	4.99	6.82	8.93	11.3	14.2	17	13

ABB Motors and Mechanical Inc.

WINDING # 37WGS137

Typical performance - not guaranteed values.

10 HP 3 PH 60 HZ 3500 RPM 460 V 3744M

TORQUES (LB-FT): PO=89.4 PU=39 LR=46.5 LRA=124

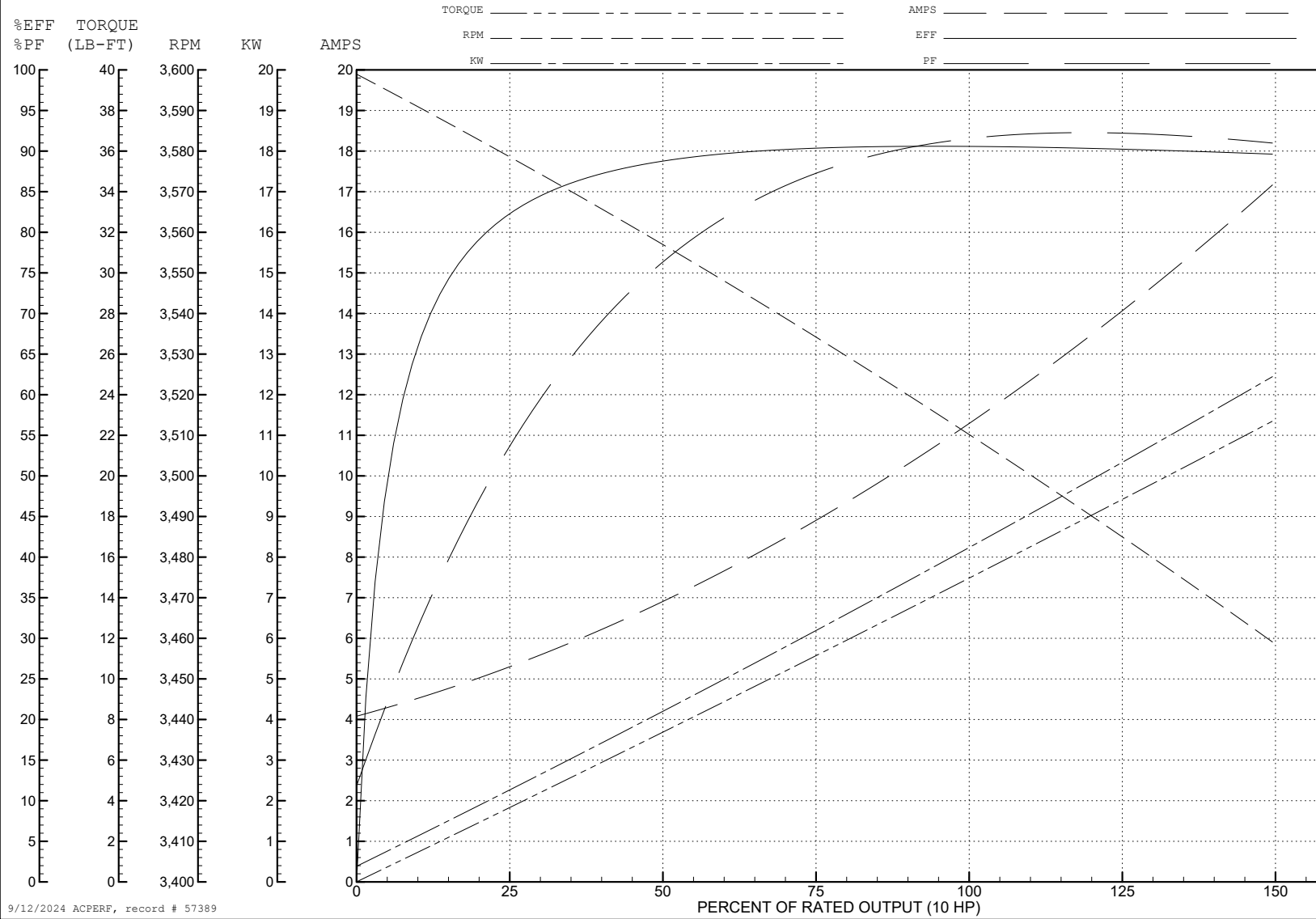

9/12/2024 ACPERF, record # 57389

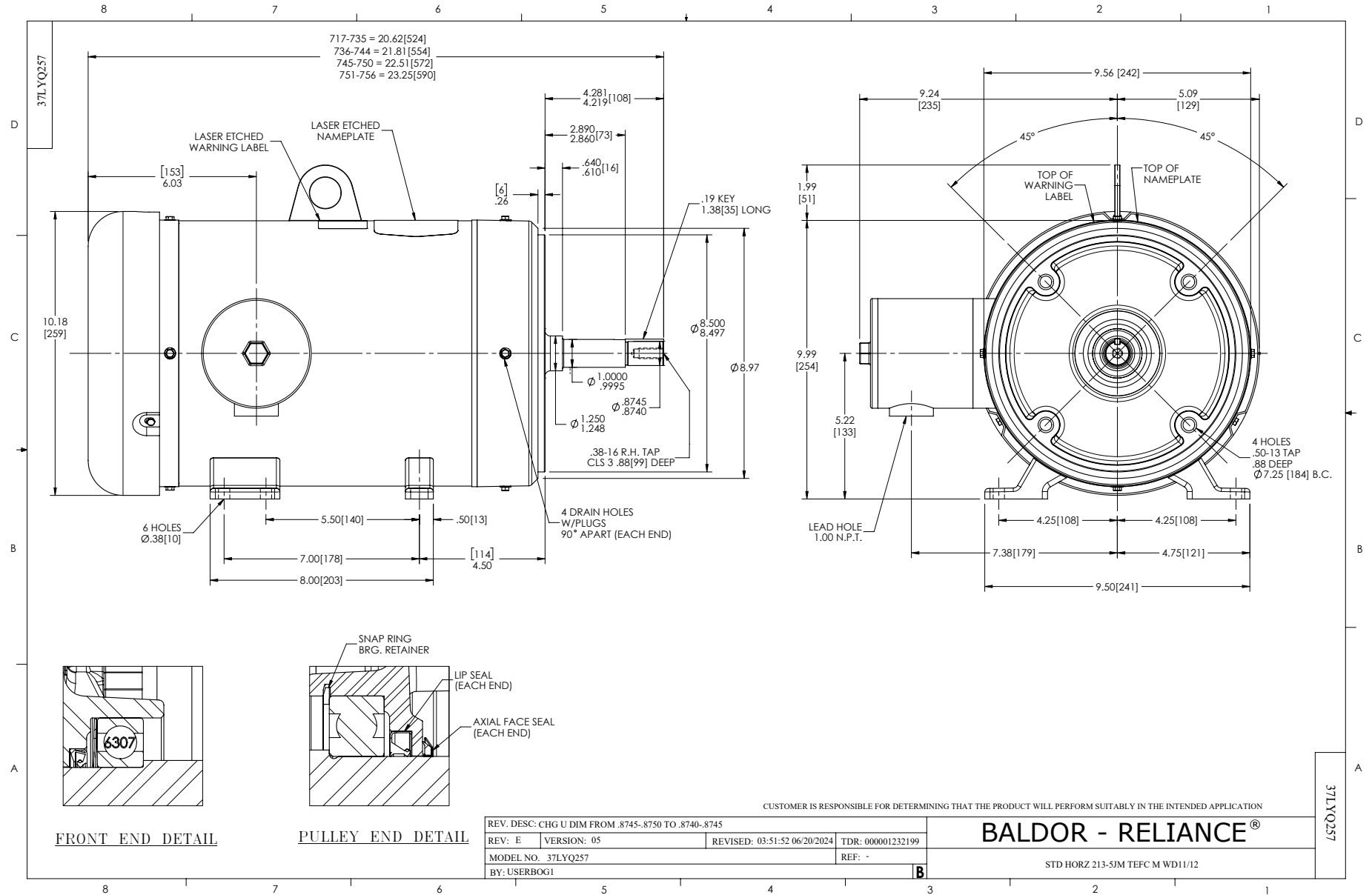



CD0005



LOW VOLTAGE  
(2Y)



LINE

HIGH VOLTAGE  
(1Y)



LINE

NOTES:

1. INTERCHANGE ANY TWO LINE LEADS TO REVERSE ROTATION.
2. OPTIONAL THERMOSTATS ARE PROVIDED WHEN SPECIFIED.
3. ACTUAL NUMBER OF INTERNAL PARALLEL CIRCUITS MAY BE A MULTIPLE OF THOSE SHOWN ABOVE.
4. LEAD COLORS ARE OPTIONAL. LEADS MUST ALWAYS BE NUMBERED AS SHOWN.

CD0005

REV. DESC: REVISE TO SHOW OPTIONAL COLORS			
REV. LTR: E	BY: JLP	REVISED: 01/19/99 10:15	TDR: 0171435
S00000		FILE: AAA00005140	MDL: -
		MTL: -	

**BALDOR ELECTRIC Co.**

3PH, DV, 9 LEADS