

BALDOR • RELIANCE

Customer information packet

JMFSWDM3709T-E

7.5HP, 3500RPM, 3PH, 60HZ, 213JM, 3734M, TEFC

Class - None

Division - Not Applicable

Specifications

Enclosure	TEFC
Frame	213JM
Frame Material	Stainless Steel
Frequency	60.00 Hz
Haz Area Class and Group	None
Haz Area Division	Not Applicable
Motor Letter Type	Three Phase
Output @ Frequency	7.500 HP @ 60 HZ
Phase	3
Synchronous Speed @ Frequency	3600 RPM @ 60 HZ
Voltage @ Frequency	230.0 V @ 60 HZ 460.0 V @ 60 HZ
Agency Approvals	CSA CSA EEV NEMA PREMIUM UR
Ambient Temperature	40 °C
Auxillary Box	No Auxillary Box
Auxillary Box Lead Termination	None
Base Indicator	Rigid
Bearing Grease Type	Polyrex EM (-20F +300F)
Blower	None
Current @ Voltage	8.300 A @ 460.0 V 19.900 A @ 208.0 V 16.800 A @ 230.0 V
Design Code	A
Drip Cover	No Drip Cover
Duty Rating	CONT
Efficiency @ 100% Load	91.0 %
Electrically Isolated Bearing	Not Electrically Isolated
Feedback Device	NO FEEDBACK
Front Face Code	Standard

Part detail

Revision	N
Type	AC
Mech. spec.	37Q257
Base	
Status	PRD/A
Elec. spec.	37WGS136
Layout	37LYQ257
Eff. date	09-22-2023
CD Diagram	CD0005
Poles	02
Leads	9#14
Proprietary	False
Created date	10-13-2017

Front Shaft Indicator	None
Heater Indicator	No Heater
High Voltage Full Load Amps	8.3 a
Insulation Class	H
Inverter Code	Inverter Ready
KVA Code	K
Lifting Lugs	Standard Lifting Lugs
Locked Bearing Indicator	Locked Bearing
Motor Lead Exit	Ko Box
Motor Lead Quantity/Wire Size	9 @ 14 AWG
Motor Lead Termination	Flying Leads
Motor Standards	NEMA
Motor Type	3734M
Mounting Arrangement	F1
Number of Poles	2
Overall Length	20.62 IN
Power Factor	93
Product Family	WD All SS Encapsulated
Pulley End Bearing Type	Sealed Bearing
Pulley Face Code	C-Face
Pulley Shaft Indicator	Tapped & Key
Rodent Screen	None
RoHS Status	ROHS COMPLIANT
Service Factor	1.15
Shaft Diameter	0.875 IN
Shaft Extension Location	Pulley End
Shaft Ground Indicator	No Shaft Grounding
Shaft Rotation	Reversible
Shaft Slinger Indicator	No Slinger
Speed	3500 rpm
Speed Code	Single Speed
Starting Method	Direct on line
Thermal Device - Bearing	None
Thermal Device - Winding	None

Vibration Sensor Indicator	No Vibration Sensor
Winding Thermal 1	None
Winding Thermal 2	None

Nameplate

NP4427AAA01										
CAT #	JMFSWDM3709T-E			WT	131	LBS				
SPEC	37Q257S136G1			ENCL	TEFC					
SER #				CC	010A	IP	69			
HP	7.5	MAG CUR	6.4/3.2							
VOLTS	230/460			NEMA NOM. EFF	91					
AMPS	16.8/8.3			PF	93					
RATING	40C AMB-CONT									
RPM	3500			MAX RPM	5400					
FRAME	213JM	HZ	60	CODE	K	CLASS	H			
SER.F.	1.15	SF AMP			PH	3	DES	A		
DE	6309	ODE	6307							
LUBRICATION	POLYREX EM									
ID LOGO	INVERTER TYPE	VPWM	CHP	60	TO	90	1.5:1			
ID LOGO	WK2	0.311	CT	15	TO	60	4:1			
ID LOGO	SL HZ	1.7	VT	6	TO	60	10:1			
				QR						
YR										

AC Induction Motor Performance Data

Record # 57387

Typical performance - not guaranteed values

Winding: 37WGS136-R005		Type: 3734M		Enclosure: TEFC	
Nameplate Data			460 V, 60 Hz: High Voltage Connection		
Rated Output (HP)	7.5	Full Load Torque	11.5 LB-FT		
Volts	230/460	Start Configuration	direct on line		
Full Load Amps	16.8/8.3	Breakdown Torque	66.3 LB-FT		
R.P.M.	3500	Pull-up Torque	25.8 LB-FT		
Hz	60	Phase	3	Locked-rotor Torque	36.7 LB-FT
NEMA Design Code	A	KVA Code	K	Starting Current	86.2 A
Service Factor (S.F.)	1.15	No-load Current	3.25 A		
NEMA Nom. Eff.	91	Power Factor	93	Line-line Res. @ 25°C	0.913 Ω
Rating - Duty	40C AMB-CONT		Temp. Rise @ Rated Load	47°C	
S.F. Amps			Temp. Rise @ S.F. Load	56°C	
			Locked-rotor Power Factor	32.4	
			Rotor inertia	0.311 LB-FT ²	

Load Characteristics 460 V, 60 Hz, 7.5 HP

% of Rated Load	25	50	75	100	125	150	S.F.
Power Factor	62	85	89	94	95	100	95
Efficiency	84.7	90.9	92.1	92	91.4	90.7	91.6
Speed	3584	3564	3541	3520	3498	3481	3508
Line amperes	3.54	4.72	6.63	8.32	10.3	11.8	9.5

ABB Motors and Mechanical Inc.

WINDING # 37WGS136

Typical performance - not guaranteed values.

7.5 HP 3 PH 60 HZ 3500 RPM 460 V 3734M

TORQUES (LB-FT): PO=66.3 PU=25.8 LR=36.7 LRA=86.2

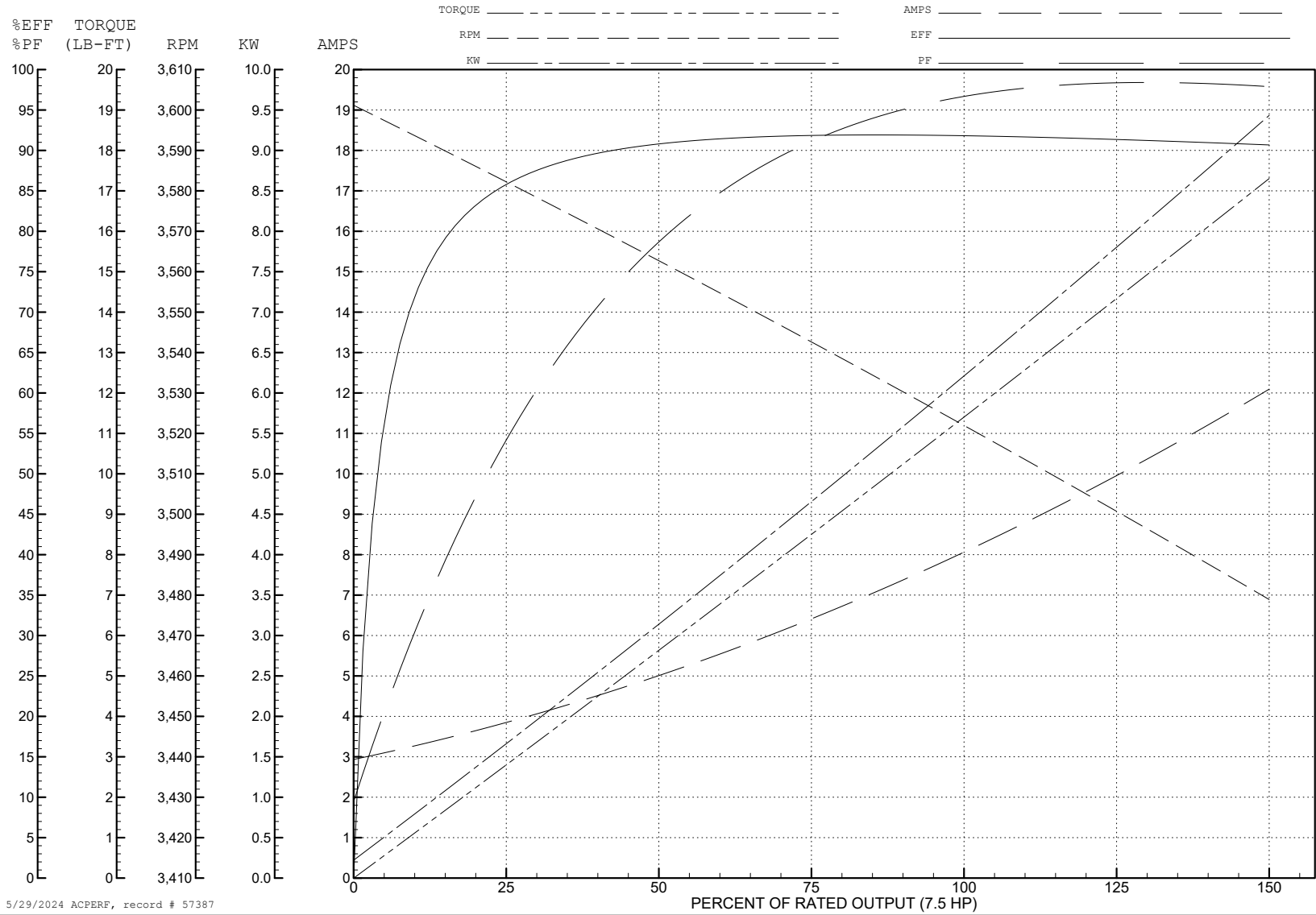

5/29/2024 ACPERF, record # 57387

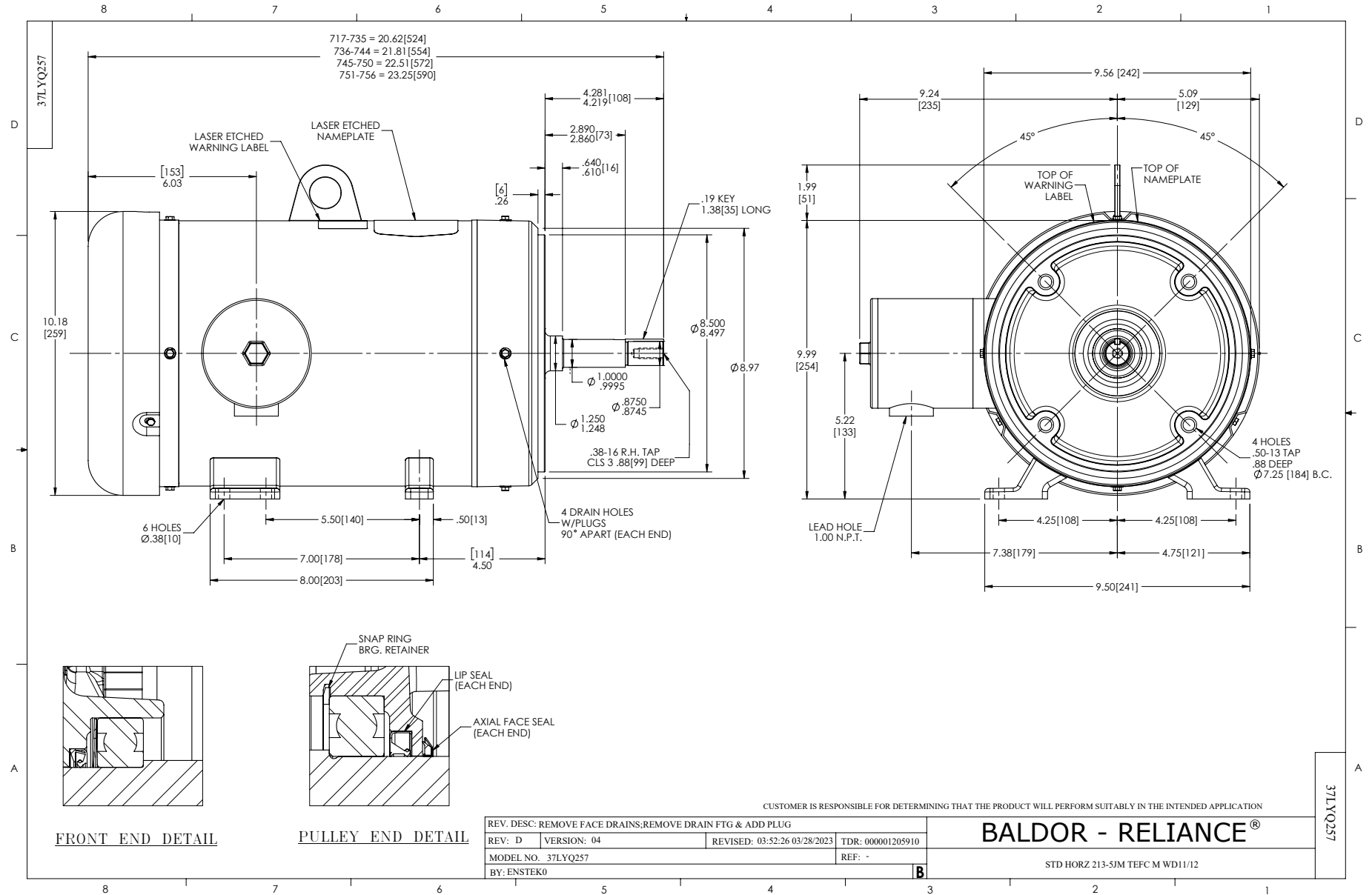

CD0005



LOW VOLTAGE
(2Y)



LINE

HIGH VOLTAGE
(1Y)



LINE

NOTES:

1. INTERCHANGE ANY TWO LINE LEADS TO REVERSE ROTATION.
2. OPTIONAL THERMOSTATS ARE PROVIDED WHEN SPECIFIED.
3. ACTUAL NUMBER OF INTERNAL PARALLEL CIRCUITS MAY BE A MULTIPLE OF THOSE SHOWN ABOVE.
4. LEAD COLORS ARE OPTIONAL. LEADS MUST ALWAYS BE NUMBERED AS SHOWN.

CD0005

REV. DESC: REVISE TO SHOW OPTIONAL COLORS			
REV. LTR: E	BY: JLP	REVISED: 01/19/99 10:15	TDR: 0171435
S00000		FILE: AAA00005140	MDL: -
		MTL: -	

BALDOR ELECTRIC Co.

3PH, DV, 9 LEADS