

# ABB BALDOR RELIANCE III

---

## Customer information packet

JM3461

.5HP, 1720RPM, 3PH, 60HZ, 56J, 3416M, TEFC, F1

Class - None

Division - Not Applicable

**Specifications**

<b>Enclosure</b>	TEFC
<b>Frame</b>	56J
<b>Frame Material</b>	Steel
<b>Frequency</b>	60.00 Hz
<b>Haz Area Class and Group</b>	None
<b>Haz Area Division</b>	Not Applicable
<b>Motor Letter Type</b>	Three Phase
<b>Output @ Frequency</b>	.500 HP @ 60 HZ
<b>Phase</b>	3
<b>Synchronous Speed @ Frequency</b>	1800 RPM @ 60 HZ
<b>Voltage @ Frequency</b>	230.0 V @ 60 HZ 460.0 V @ 60 HZ
<b>Agency Approvals</b>	CSA UR
<b>Ambient Temperature</b>	40 °C
<b>Auxiliary Box</b>	NO AUXILLARY BOX
<b>Auxiliary Box Lead Termination</b>	None
<b>Base Indicator</b>	No Mounting
<b>Bearing Grease Type</b>	Polyrex EM (-20F +300F)
<b>Blower</b>	None
<b>Current @ Voltage</b>	.800 A @ 460.0 V 1.600 A @ 230.0 V 1.700 A @ 208.0 V
<b>Design Code</b>	B
<b>Drip Cover</b>	No Drip Cover
<b>Duty Rating</b>	CONT
<b>Efficiency @ 100% Load</b>	75.5 %
<b>Electrically Isolated Bearing</b>	Not Electrically Isolated
<b>Feedback Device</b>	NO FEEDBACK
<b>Front Shaft Indicator</b>	None
<b>Heater Indicator</b>	No Heater
<b>High Voltage Full Load Amps</b>	0.8 a

**Part Detail**

<b>Revision</b>	B
<b>Type</b>	AC
<b>Mech. spec.</b>	34K036
<b>Base</b>	
<b>Status</b>	PRD/A
<b>Elec. spec.</b>	34WGR706
<b>Layout</b>	34LYK036
<b>Eff. date</b>	10-28-2024
<b>CD Diagram</b>	CD0005
<b>Poles</b>	04
<b>Leads</b>	9#18 Y
<b>Proprietary</b>	False
<b>Created date</b>	01-29-2021

<b>Insulation Class</b>	B
<b>Inverter Code</b>	Not Inverter
<b>KVA Code</b>	J
<b>Lifting Lugs</b>	No Lifting Lugs
<b>Locked Bearing Indicator</b>	Locked Bearing
<b>Motor Lead Quantity/Wire Size</b>	9 @ 18 AWG
<b>Motor Lead Termination</b>	Flying Leads
<b>Motor Standards</b>	NEMA
<b>Motor Type</b>	3416M
<b>Mounting Arrangement</b>	F1
<b>Number of Poles</b>	4
<b>Overall Length</b>	11.84 IN
<b>Power Factor</b>	75
<b>Product Family</b>	General Purpose
<b>Pulley End Bearing Type</b>	Ball
<b>Pulley Face Code</b>	C-Face
<b>Pulley Shaft Indicator</b>	Ext Thread
<b>Rodent Screen</b>	None
<b>Service Factor</b>	1.25
<b>Shaft Diameter</b>	0.625 IN
<b>Shaft Ground Indicator</b>	No Shaft Grounding
<b>Shaft Rotation</b>	Reversible
<b>Shaft Slinger Indicator</b>	No Slinger
<b>Speed</b>	1720 rpm
<b>Speed Code</b>	Single Speed
<b>Starting Method</b>	Direct on line
<b>Thermal Device - Bearing</b>	None
<b>Thermal Device - Winding</b>	None
<b>Vibration Sensor Indicator</b>	No Vibration Sensor
<b>Winding Thermal 1</b>	None
<b>Winding Thermal 2</b>	None

**Nameplate**

<b>NP1256L</b>									
<b>CAT.NO.</b>	JM3461								
<b>SPEC.</b>	34K036R706								
<b>HP</b>	.5								
<b>VOLTS</b>	230/460								
<b>AMP</b>	1.6/.8								
<b>RPM</b>	1720								
<b>FRAME</b>	56J		<b>HZ</b>	60			<b>PH</b>	3	
<b>SER.F.</b>	1.25	<b>CODE</b>	J	<b>DES</b>	B	<b>CLASS</b>		B	
<b>NEMA-NOM-EFF</b>	75.5	<b>PF</b>	75						
<b>RATING</b>	40C AMB-CONT								
<b>CC</b>									
<b>DE</b>	6203		<b>ODE</b>	6203					
<b>ENCL</b>	TEFC	<b>SN</b>							
	SFA 1.9/0.95								

**Accessories**

<b>Part number</b>	<b>Description</b>	<b>Multiplier</b>
34-171	C FACE KIT	A8

ABB Motors and Mechanical Inc.

WINDING # 34WGR706

0.5 HP 3 PH 60 HZ 1720 RPM 460 V 3416M

Typical performance - not guaranteed values.

TORQUES (LB-FT): PO=5.15 PU=2.87 LR=3.94 LRA=5

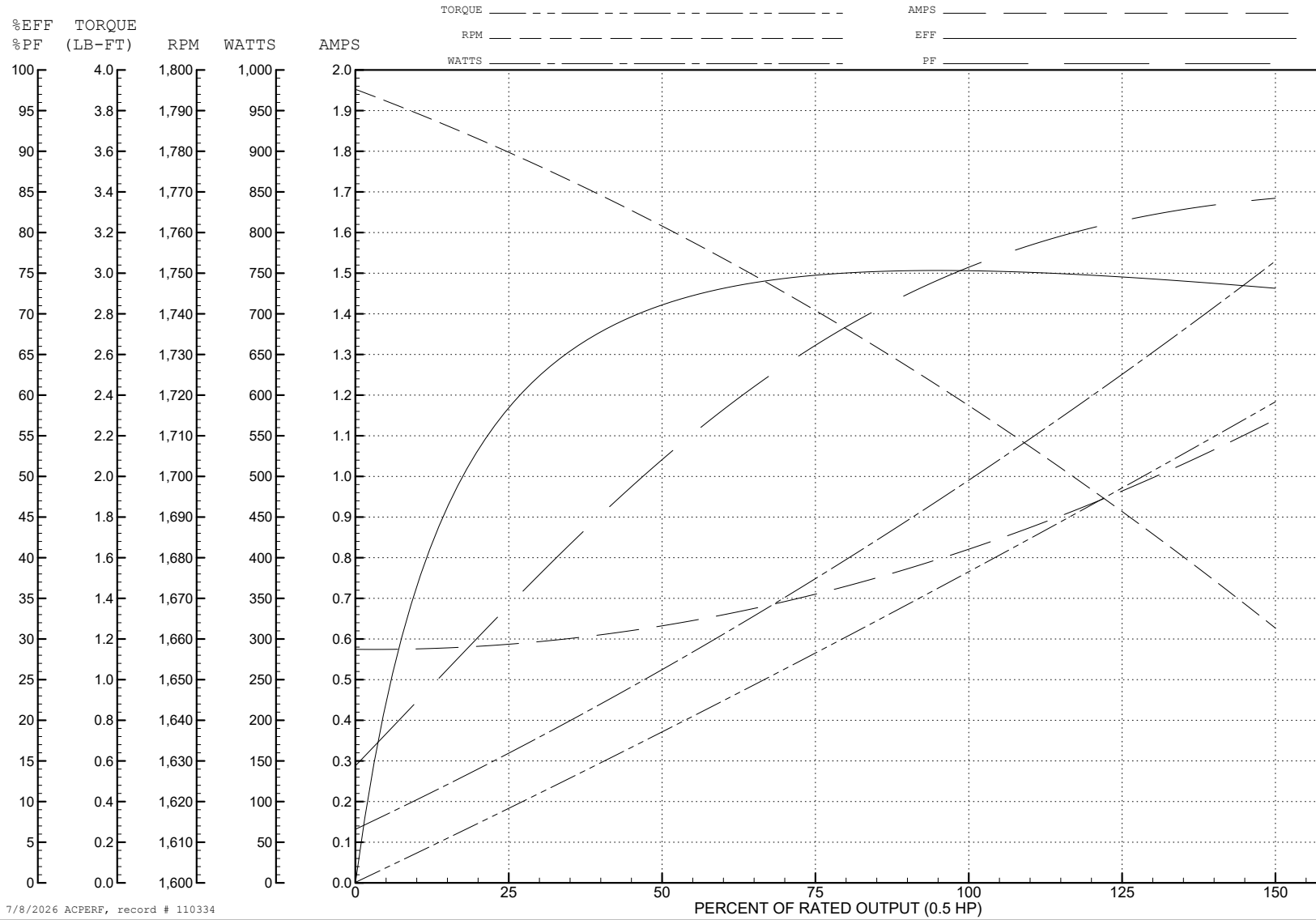

7/8/2026 ACPERF, record # 110334

34LYK036

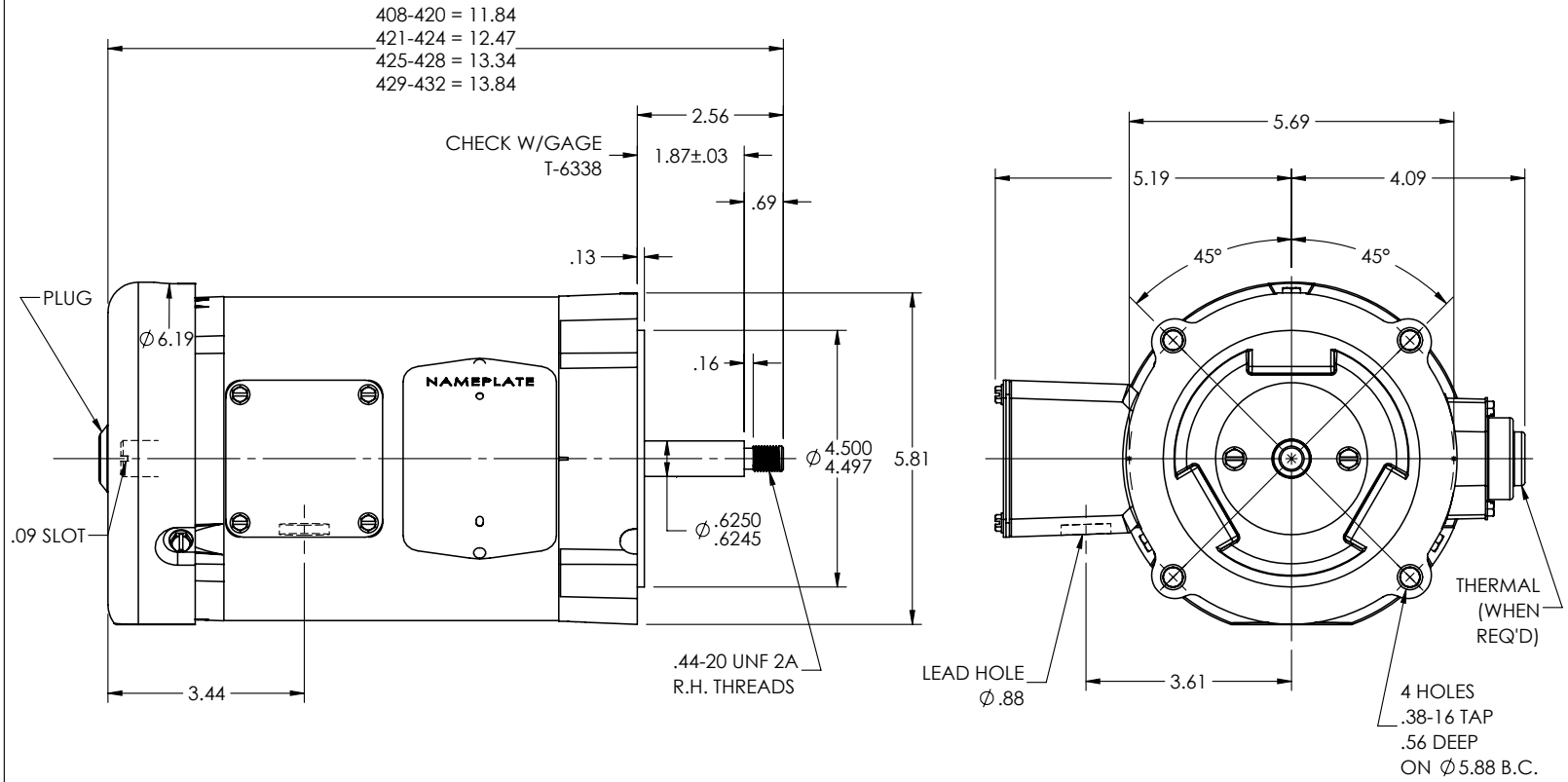

CUSTOMER IS RESPONSIBLE FOR DETERMINING THAT THE PRODUCT WILL PERFORM SUITABLY IN THE INTENDED APPLICATION

REV. DESC: LOAD TO SOLIDWORKS - REV G

REV: H    VERSION: 03    REVISED: 04:25:22 12/19/2022    TDR: 000001201165

34LYK036

MODEL NO. 34LYK036  
BY: ENFRAJ0

REF: -

**BALDOR - RELIANCE®**

STD VERT MODEL 34M NEMA 56J TEFC

34LYK036

CD0005



LOW VOLTAGE  
(2Y)



LINE

HIGH VOLTAGE  
(1Y)

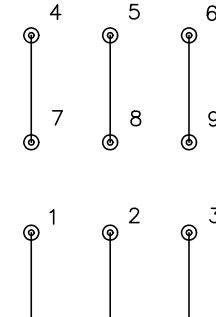

LINE

**NOTES:**

1. INTERCHANGE ANY TWO LINE LEADS TO REVERSE ROTATION.
2. OPTIONAL THERMOSTATS ARE PROVIDED WHEN SPECIFIED.
3. ACTUAL NUMBER OF INTERNAL PARALLEL CIRCUITS MAY BE A MULTIPLE OF THOSE SHOWN ABOVE.
4. LEAD COLORS ARE OPTIONAL. LEADS MUST ALWAYS BE NUMBERED AS SHOWN.

CD0005

REV. DESC: REVISE TO SHOW OPTIONAL COLORS

REV. LTR: E BY: JLP REVISED: 01/19/99 10:15 TDR: 0171435

500000

FILE: AAA00005140

MDL: -

MTL: -

**BALDOR ELECTRIC Co.**

3PH, DV, 9 LEADS