

RPM-AC FINNED FRAME VARIABLE SPEED ALTERNATING CURRENT MOTOR FL3614Z

ENCLOSURE: TOTALLY ENCLOSED

COOLING: BLOWER COOLED

MOUNTING: FOOT

ACCESSORIES: PROVISIONS FOR TACHOMETER MOUNTING ONLY WHEN SPECIFIED

DRIVE METHOD: COUPLED OR BELTED

619682-001

D

C

B

A

D

C

B

A

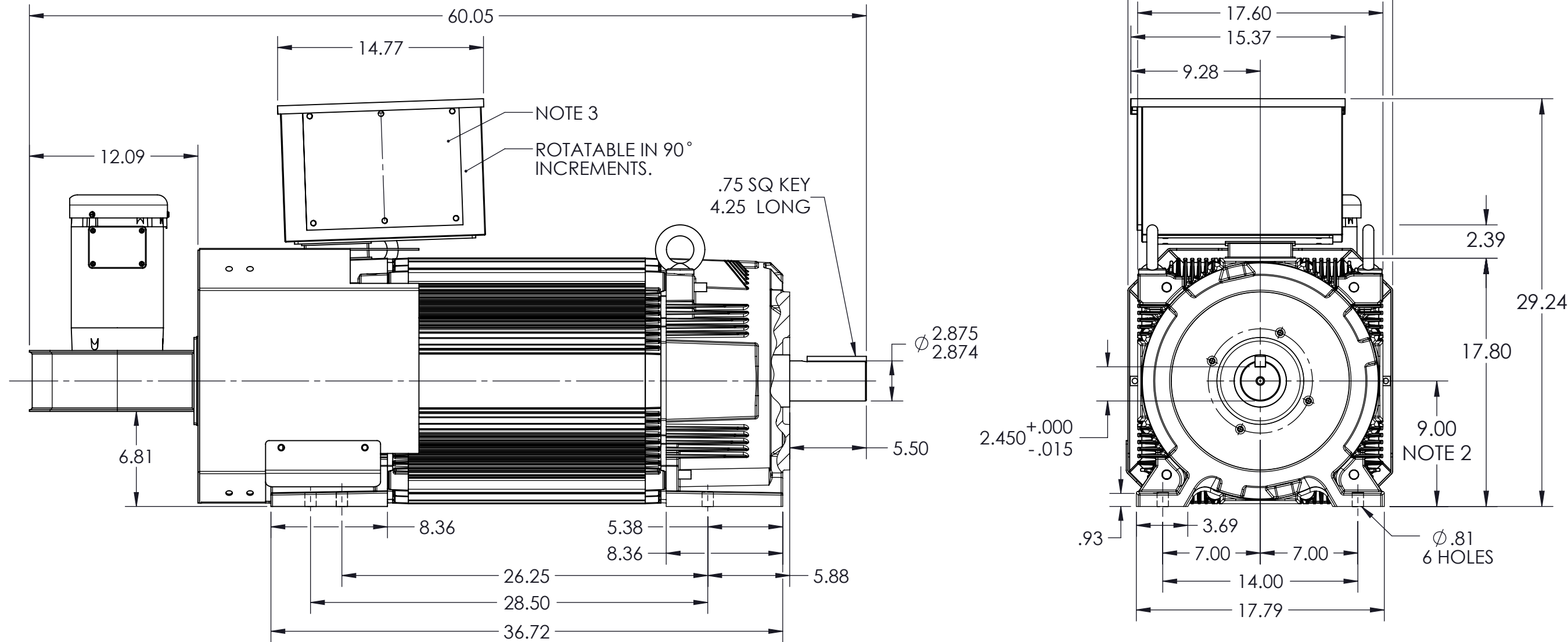

- NOTES:
1. O.D.E. C-FACE & TACHOMETER MOUNTING. 1/2-13 TAP, 1.00 DEEP, ON A ϕ 7.25 B.C. FACE RUNOUT AND ECCENTRICITY 0.004 MAX. T.I.R.
 2. SHAFT HEIGHT WILL NOT BE EXCEEDED. SHIMS UP TO 0.06 INCHES IN THICKNESS ARE USUALLY REQUIRED FOR COUPLED OR GEARED MACHINES.
 3. REMOVABLE COVER PLATE FOR CUSTOMER DRILLING.

- TERMINAL BOX MAY BE LOCATED F1, F2, OR F3 IF SPECIFIED.
- REFER TO 616779-55 FOR SPECIFIED TACHOMETER DIMENSIONS.

DIMENSIONS ARE IN INCHES

MOTOR WEIGHT: 2130 LBS. (MAY VARY 15% FOR NON-STANDARD RATINGS AND / OR ACCESSORIES.)

CUSTOMER IS RESPONSIBLE FOR DETERMINING THAT BALDOR'S PRODUCT WILL PERFORM SUITABLY IN THE INTENDED APPLICATION

REV. DESC: REMOVED 1/4" FROM SHAFT EXT "V" DIM			
REV: B	VERSION: 02	REVISED: 01:41:03 12/17/2014	TDR: 00000884351
MODEL NO. 619682-001		REF:	
BY: MGH TLC		B	

BALDOR

DIM SHEET, FL3614Z, FOOTED, RPM-AC, TEBC

619682-001