

ABB BALDOR RELIANCE III

Customer information packet IDBRPM25604

60HP, 1750, 460V, FL2578, TEBC, F3

Specifications

Enclosure	TEBC
Frame	FL2578Z
Frame Material	Exposed Laminations
Frequency	60.00 Hz
Output @ Frequency	60.000 HP @ 60 HZ
Phase	3
Synchronous Speed @ Frequency	1800 RPM @ 60 HZ
Voltage @ Frequency	460.0 V @ 60 HZ
Agency Approvals	CCSA US
Auxiliary Box	NO AUXILLARY BOX
Base Indicator	Rigid
Bearing Grease Type	Polyrex EM (-20F +300F)
Current @ Voltage	75.000 A @ 460.0 V
Duty Rating	CONT
Feedback Device	NO FEEDBACK
Frame Prefix	FL
Heater Indicator	No Heater
High Voltage Full Load Amps	75.0 a
Insulation Class	H
IP Rating	NONE
Motor Standards	NEMA
Mounting Arrangement	F3
Overall Length	33.85 IN
Product Family	General Industrial
Pulley End Bearing Type	Ball
Pulley Face Code	Standard
Service Factor	1.00
Shaft Diameter	2.124 IN
Shaft Ground Indicator	Shaft Grounding
Shaft Rotation	Reversible
Speed	1775 rpm
Starting Method	Full Voltage

Part Detail

Revision	A
Type	AC
Mech. spec.	
Base	
Status	PRD/A
Elec. spec.	L3381A
Layout	617577-053
Eff. date	01-21-2022
CD Diagram	422927-001
Poles	04
Leads	
Proprietary	False
Created date	10-20-2021

Thermal Device - Bearing

None

Thermal Device - Winding

Normally Closed Thermostat

Nameplate

000613006MY

	DUTY	HP	RPM	AMPS	VOLTS	HZ	
	CONT	60	1775	75	460	60	
	CONT	60	3540	71	460	120	
CAT.NO.	IDBRPM25604		SPEC. NO.	F25-A000-0401			
SER.NO		FR	FL2578Z	INSUL	H		
PH.	3	MAX SAFE SPEED	5000	AMB.	40	MIN. AMB.	-25
DESIGN NO.	L3381A	TYPE		ENCL.	TEAO-BC		
S.F.	1.00		D.E. BRG.	65BC03JPP30A			
ENCL MOD		O.D.E. BRG.	50BC03JPP30A				
	IP44						

REL S.O.	-	VOLTS	460	ENCLOSURE	TEBC	WYE CONN EQ CKT OHMS PER PHASE			
FRAME	FL2578	AMPS	75	MAX SAFE RPM	5000	(AT BASE RATING, 25 °C)			
HP	60	DUTY	CONT	IM (AMPS)	35	R1	.0612	X1	.309
BASE SPEED	1775	S.F.	1.0	P.F. @NL/FL	.048/.819	R2	.0409	X2	.427
PHASE/HERTZ	3/60	AMB °C/INSUL	40/H	WK ² (Lb-Ft ²)	4.2			XM	7.77

RATED FULL LOAD DATA

	RPM	HP	TORQUE LB-FT	FUND VOLTS	FREQ-HZ	AMPS
BASE SPEED	1774	60.0	178	460	60	75.0
MAX SPEED	3542	60.0	89	460	120	71.2
MIN SPEED	0	0	178	13.4	.865	75.0

LOAD PERFORMANCE AT BASE SPEED

	RPM	HP	TORQUE LB-FT	FUND VOLTS	FREQ-HZ	AMPS
NO LOAD	1800	0	0	460	60	34.3
1/4	1794	15.0	44	460	60	38.9
1/2	1788	30.0	88	460	60	48.1
3/4	1781	45.0	133	460	60	60.6
FULL LOAD	1774	60.0	178	460	60	75.0
O/L	1742	118	355	460	60	142

REMARKS: TYPICAL DATA
CORRELATED DATA



DR. BY B. GRANT
 CK. BY B. GRANT
 APP. BY T. CUFR
 DATE 8-11-06

**A-C MOTOR
PERFORMANCE DATA** L3381A
 ISSUE DATE 8-11-06

REL S.O.	-	VOLTS	460	ENCLOSURE	TEBC	WYE CONN EQ CKT OHMS PER PHASE	
FRAME	FL2578	AMPS	75	MAX SAFE RPM	5000	(AT BASE RATING, 25 °C)	
HP	60	DUTY	CONT	IM (AMPS)	35	R1	.0612 X1 .309
BASE SPEED	1775	S.F.	1.0	P.F. @NL/FL	.048/.819	R2	.0409 X2 .427
PHASE/HERTZ	3/60	AMB °C/INSUL	40/H	WK ² (Lb-Ft ²)	4.2		XM 7.77

CORRELATED DATA
VARIABLE SPEED AC MOTOR CURVES

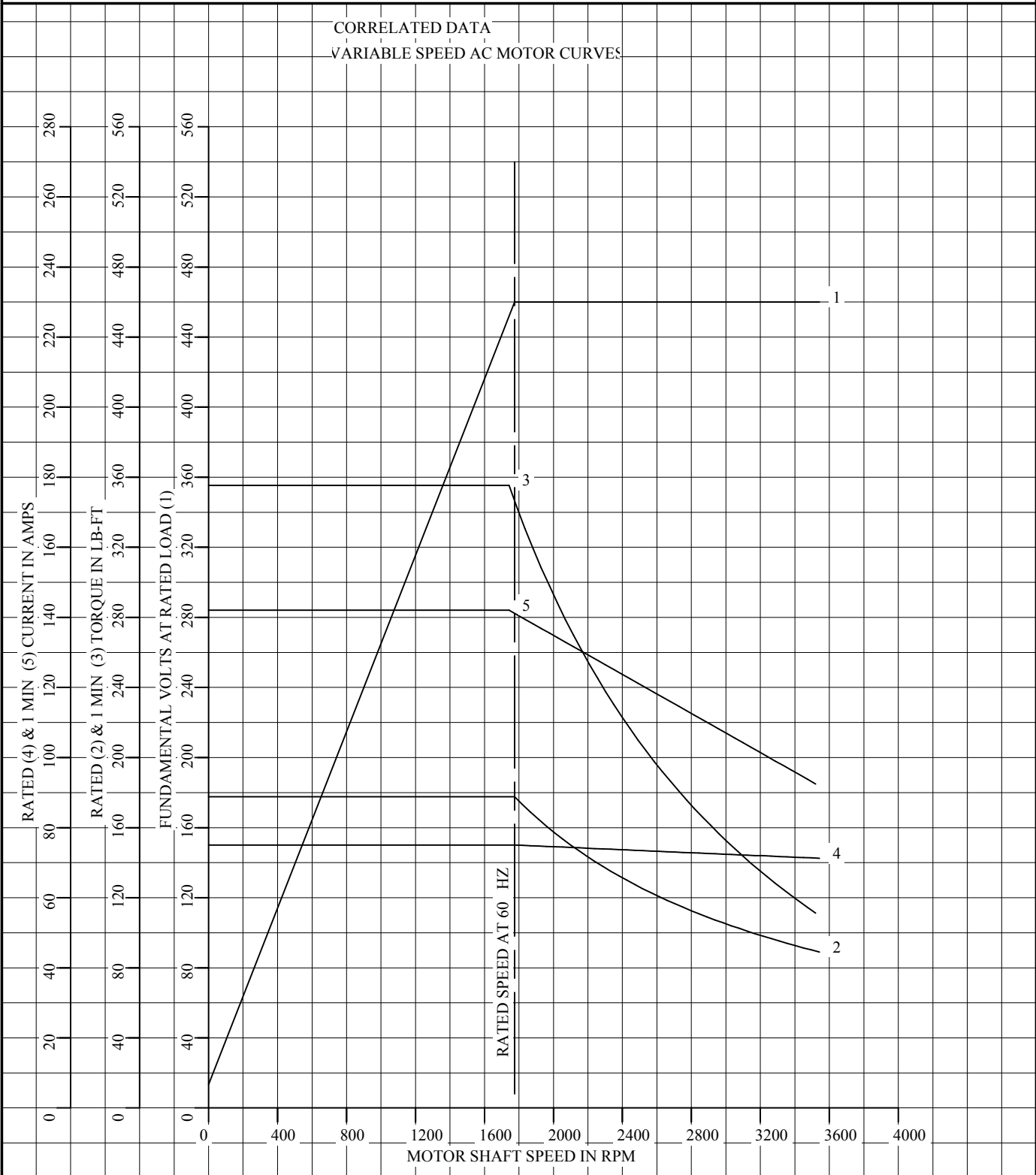

REMARKS: TYPICAL DATA
DATA VALID FOR NAMEPLATE SPEED RANGE ONLY



DR. BY B. GRANT
CK. BY B. GRANT
APP. BY T. CUFR
DATE 8-11-06

**A-C MOTOR
PERFORMANCE
CURVES**

L3381A
SH 1 OF 2
ISSUE DATE 8-11-06 Page 6 of 10

REL S.O.	-	VOLTS	460	ENCLOSURE	TEBC	WYE CONN EQ CKT OHMS PER PHASE	
FRAME	FL2578	AMPS	75	MAX SAFE RPM	5000	(AT BASE RATING, 25 °C)	
HP	60	DUTY	CONT	IM (AMPS)	35	R1	.0612 X1 .309
BASE SPEED	1775	S.F.	1.0	P.F. @NL/FL	.048/.819	R2	.0409 X2 .427
PHASE/HERTZ	3/60	AMB °C/INSUL	40/H	WK ² (Lb-Ft ²)	4.2		XM 7.77

CORRELATED DATA
LOAD PERFORMANCE (CONSTANT V/HZ RANGE)

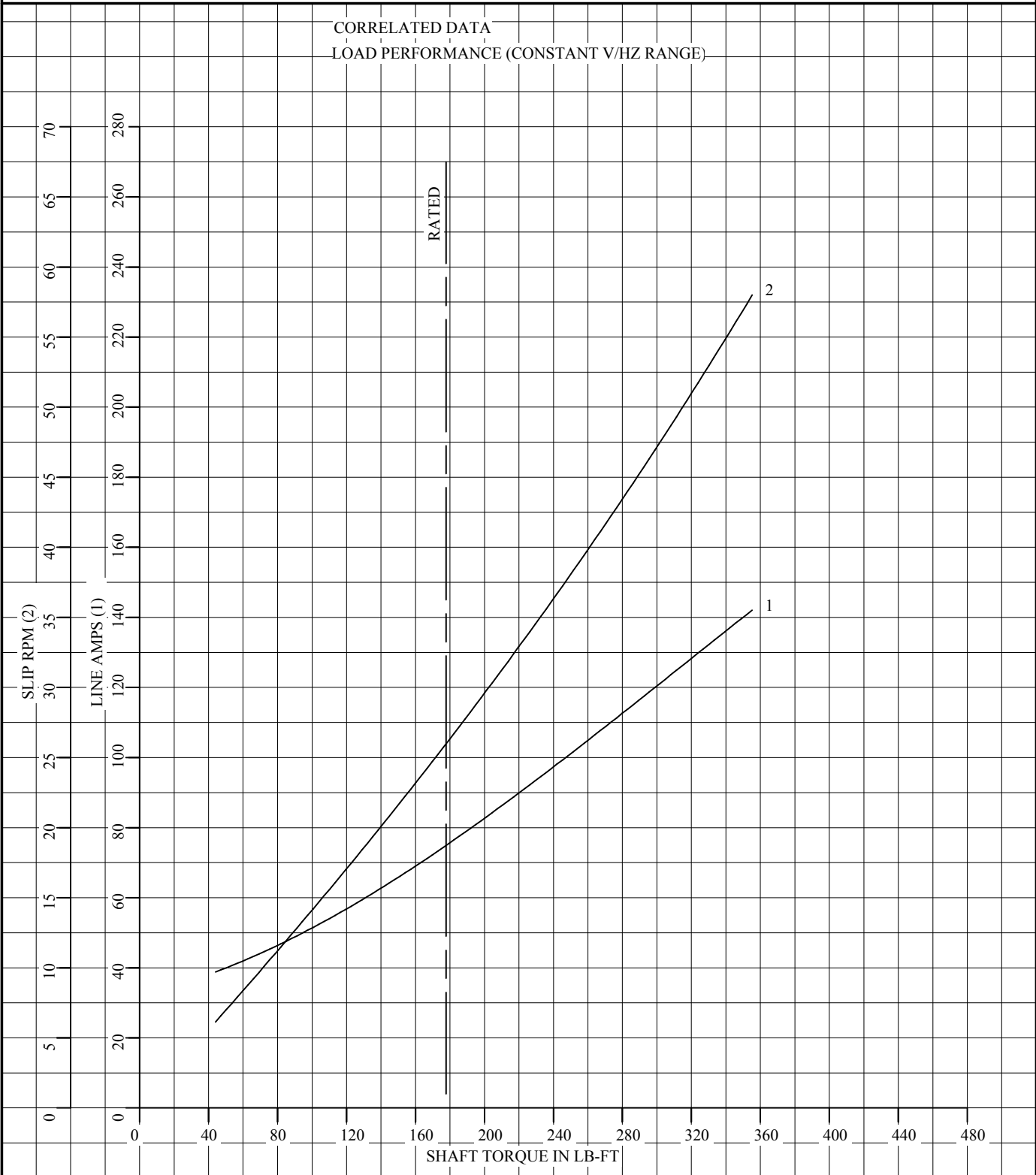

REMARKS: TYPICAL DATA
DATA VALID FOR NAMEPLATE SPEED RANGE ONLY



DR. BY B. GRANT
CK. BY B. GRANT
APP. BY T. CUFR
DATE 8-11-06

**A-C MOTOR
PERFORMANCE
CURVES**

L3381A
SH 2 OF 2
ISSUE DATE 8-11-06 Page 7 of 10

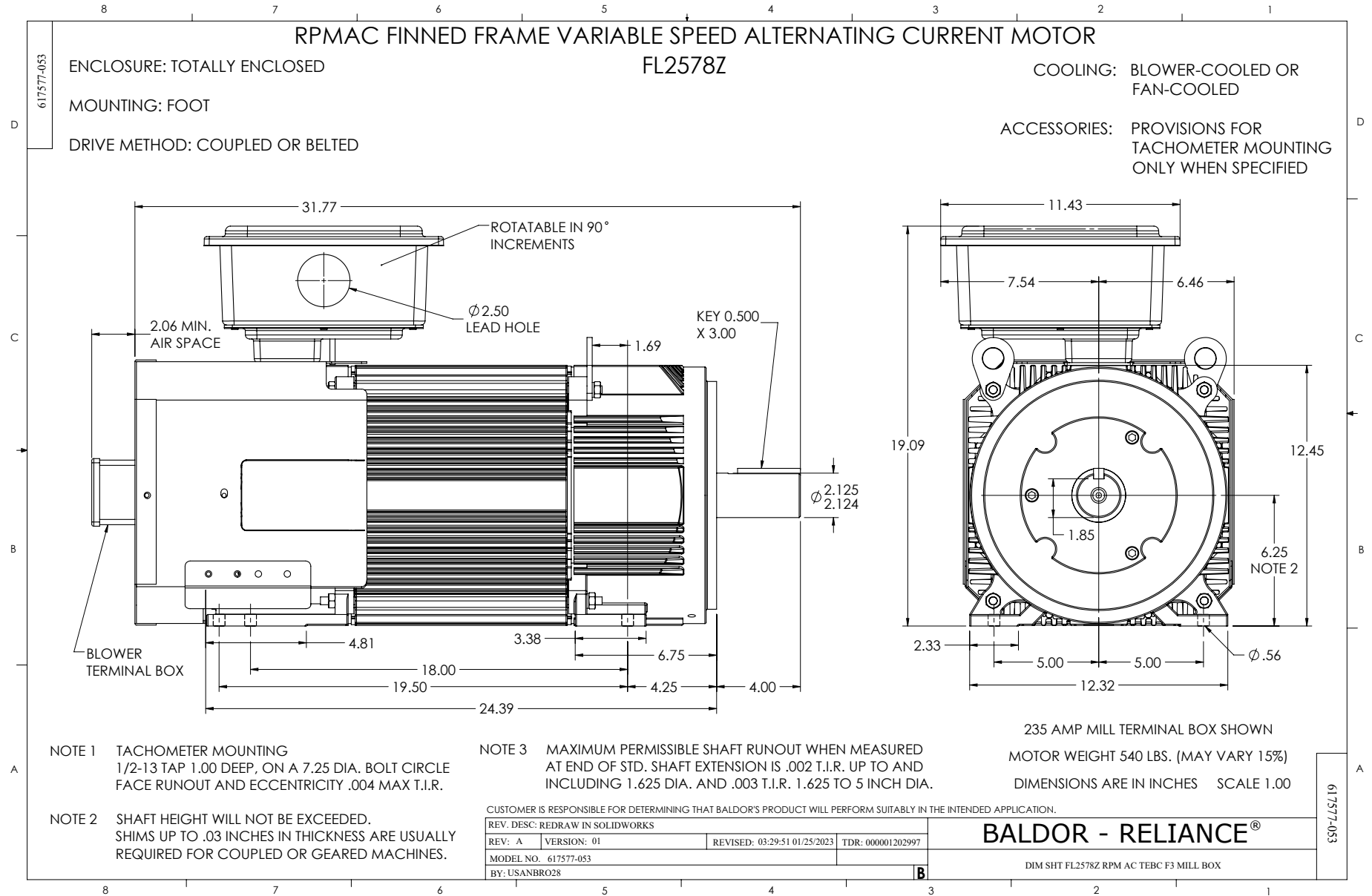

INDUSTRIAL ALTERNATING CURRENT MOTORS
RPM AC

STEEL, CAST IRON, MILL AND TERMINAL BOARD CONDUIT BOX DIMENSIONS
NEMA FRAMES RL210 thru RL280 and IEC FRAMES RDL132 thru RDL180
NEMA FRAMES FL180 thru FL280 and IEC FRAMES FDL112 thru FDL180

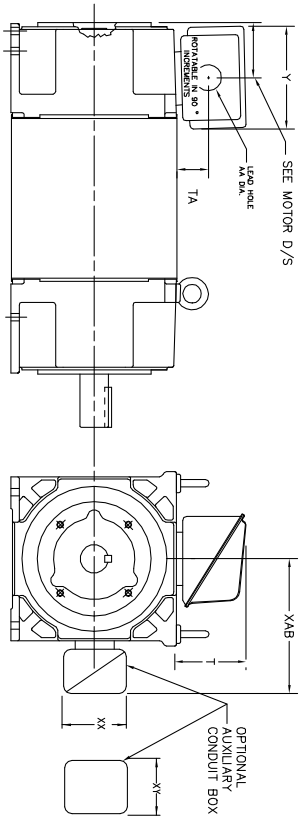

FRAME	TYPE	TERMINAL STRIP	AMPS	C/BOX	Y	TA	T	AA
FL180	STEEL	N	40	706320003A	5.00	1.62	3.00	1.12
FL180	STEEL	N	75	706320003A	6.12	2.38	4.38	1.75/2.00
FL180	STEEL	N	208	706320007A	6.82	2.00	7.00	2.50/2.00
FL180	CAST IRON	Y/N	40	706320004A	5.75	2.38	4.38	1.50/1.75
FL180 & FDL11	MILL	Y	100	706310028A	7.75	2.30	4.40	PC29/PG16
FL210 & RL210	STEEL	N	61	0754520009	6.34	2.00	4.12	1.75
FL210 & RL210	STEEL	N	121	075452001A	7.69	2.38	5.25	1.94
FL210 & RL210	STEEL	N	336	706320016A	9.00	4.12	8.42	4.89
FL210 & RL210	CAST IRON	N	110	075460052B	7.25	2.50	5.25	1.5 TAP
FL210 & RL210	MILL	Y	100	706310229A	7.75	2.30	4.40	PC29/PG16
FL210 & RL210	MILL	Y	160	706310056A	9.00	3.06	5.40	PC36/PG16
FL210 & RL210	MILL	Y/N	235	706310058B	11.42	4.00	6.72	2.50
FL250 & RL250	STEEL	N	61	0754520009	6.34	2.00	4.12	1.75
FL250 & RL250	STEEL	N	121	075452001A	7.69	2.38	5.25	1.94
FL250 & RL250	STEEL	N	336	706320016A	9.00	4.12	8.42	4.89
FL250 & RL250	CAST IRON	N	110	075460052B	7.25	2.50	5.25	1.5 TAP
FL250 & RL250	CAST IRON	N	210	706320013A	10.50	4.88	9.00	4.0 TAP
FL250 & RL250	MILL	Y	100	706310229A	7.75	2.30	4.40	PC29/PG16
FL250 & RL250	MILL	Y	160	706310056A	9.00	3.06	5.40	PC36/PG16
FL250 & RL250	MILL	Y/N	235	706310058B	11.42	4.00	6.72	2.50
FL250 & RL250	MILL	Y	400	706310063B	14.39	7.43	12.15	BLANK
FL280 & RL280	STEEL	N	160	706310058B	9.00	3.06	5.40	PC36/PG16
FL280 & RL280	STEEL	N	309	706320018	9.00	4.12	8.42	4.89
FL280 & RL280	STEEL	N	500	702565001C	14.62	7.56	12.70	5.00
FL280 & RL280	CAST IRON	N	140	706320012B	9.25	4.81	8.56	3.0 TAP
FL280 & RL280	CAST IRON	N	210	706320013A	10.50	4.88	9.00	4.0 TAP
FL280 & RL280	CAST IRON	N	510	706320014D	15.00	7.56	12.81	5.0 TAP
FL280 & RL280	MILL	Y	100	706310056A	7.75	2.30	4.40	PC29/PG16
FL280 & RL280	MILL	Y	160	706310058B	9.00	3.06	5.40	PC36/PG16
FL280 & RL280	MILL	Y/N	235	706310057A	11.42	4.00	6.72	2.50
FL280 & RL280	MILL	Y	400	706310063B	14.39	7.43	12.15	BLANK

FRAME SIZE	XAB	XX	XY	PART NUMBER	FRAME SIZE	XAB	XX	XY	PART NUMBER
FL107/FL160/FL210/FL182	7.38	4.25	4.25	602007-26-A	FL107/FL160/FL210/FL182	10.88	8.00	8.00	706310-3-B
FL250/FL180/FL280/FL180	8.44	4.25	4.25	602007-26-A	FL250/FL180/FL280/FL180	11.88	8.00	8.00	706310-3-B
FL280/FL180/FL280/FL180	9.12	4.25	4.25	602007-26-A	FL280/FL180/FL280/FL180	12.62	8.00	8.00	706310-3-B

(1) 1/4" PIPE TAP.
(2) 1/2" PIPE TAP.
(3) CUSTOMER TO PROVIDE W/LE TYP CONDUIT.
(4) 2" DIA. SA OR 1" DIA. DN W/2"

TERMINAL BOX CAN BE ROTATED FOR LEAD INLET AT TOP, SIDES OR BOTTOM.
TERMINAL BOX LOCATED ON OPPOSITE SIDE WHEN F-2, V-1, V-4, V-5, V-7.
DR C-1 MOUNTING IS SPECIFIED. BOX LOCATED ON TOP WHEN SPECIFIED.

050-677919

CUSTOMER IS RESPONSIBLE FOR DETERMINING THAT BALDOR'S PRODUCT WILL PERFORM SUITABLY IN THE INTENDED APPLICATION.

REV. DESC: ADD 706310-637 & 639 BOX	VERSION: 06	TDR: 000001180260
REV. LTR: F	REVISED: 11: 08: 56 10/26/2021	BY: RCGRWM
FILE: \\RGG\00003\692		
MTL: -		

BALDOR - RELIANCE®
DIM SHT NEMA RL210-RL280 FL180-FL280 IEC RDL132-RDL180
SH 1 of 1

422927-001



NOTE:
DATA TO BE SIZED
SO THAT IT FITS INTO
MATERIAL DECAL
DIMENSIONS. MAKE
LETTERS & NUMBERS
AS LARGE AS POSSIBLE.

MATERIAL: CERAMATIC DGF-P4
PERMA GRIP ADHESIVE

ALL LETTERS, NUMBERS
AND LINES TO BE BLACK
ON WHITE BACKGROUND.

422927-001

REV. DESC: CHANGE BACKGROUND COLOR FROM GOLD TO WHITE		
REV. LTR: B	VERSION: 02	TDR: 00000788708
FILE: \RGG\00000\203	REVISED: 08:09:29 03/04/2013	
MTL: -	BY: RGGWT	

BALDOR

EXTERNAL CONNECTION LABEL

SH 1 of 1