

DUTY MASTER ALTERNATING CURRENT MOTORS

SQUIRREL-CAGE INDUCTION
CAST IRON CONSTRUCTION

FRAMES 444TS-445TS

COOLING: SELF-VENTILATED

ENCLOSURE: PROTECTED
MOUNTING: FOOT

617428-109

D

C

B

A

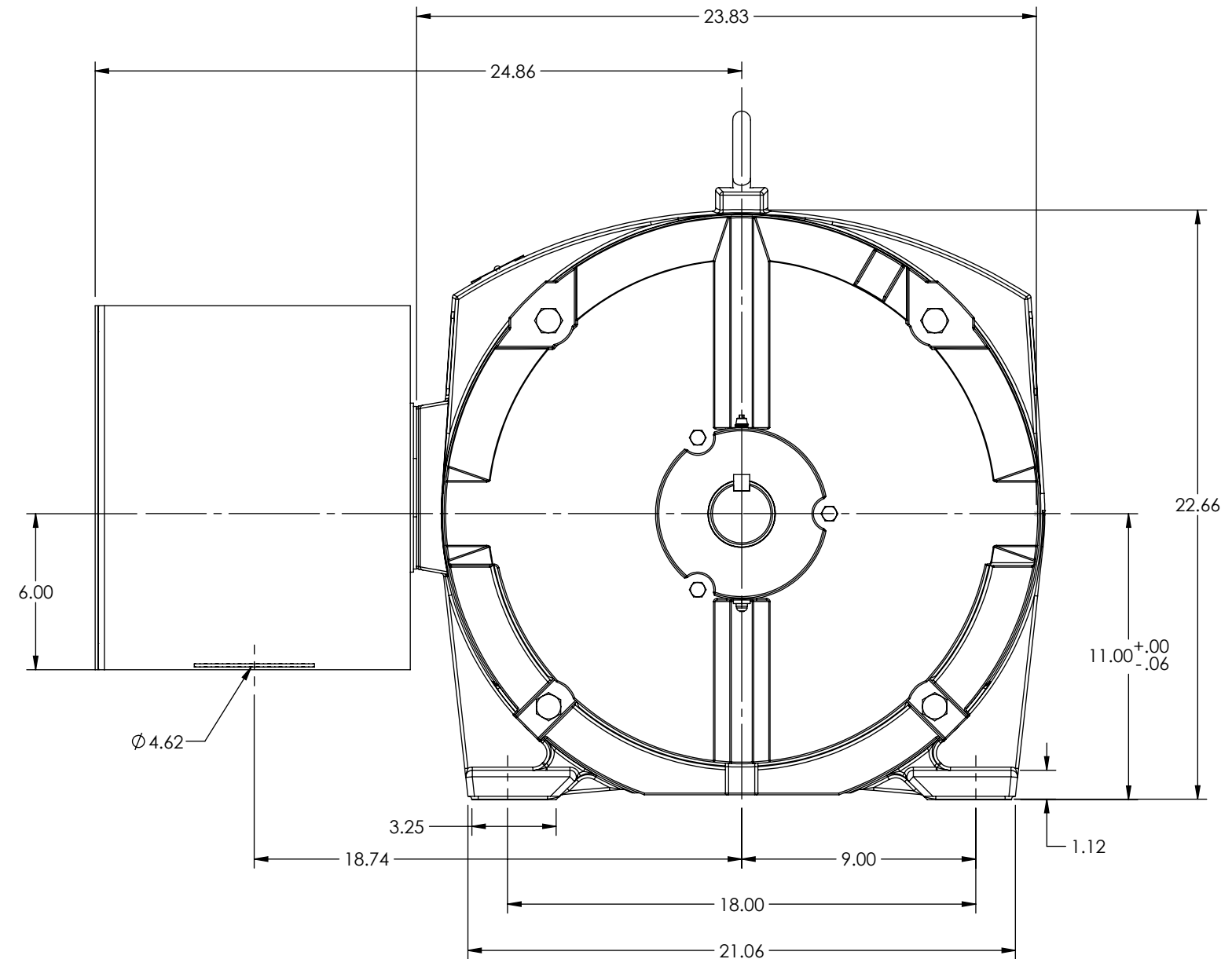
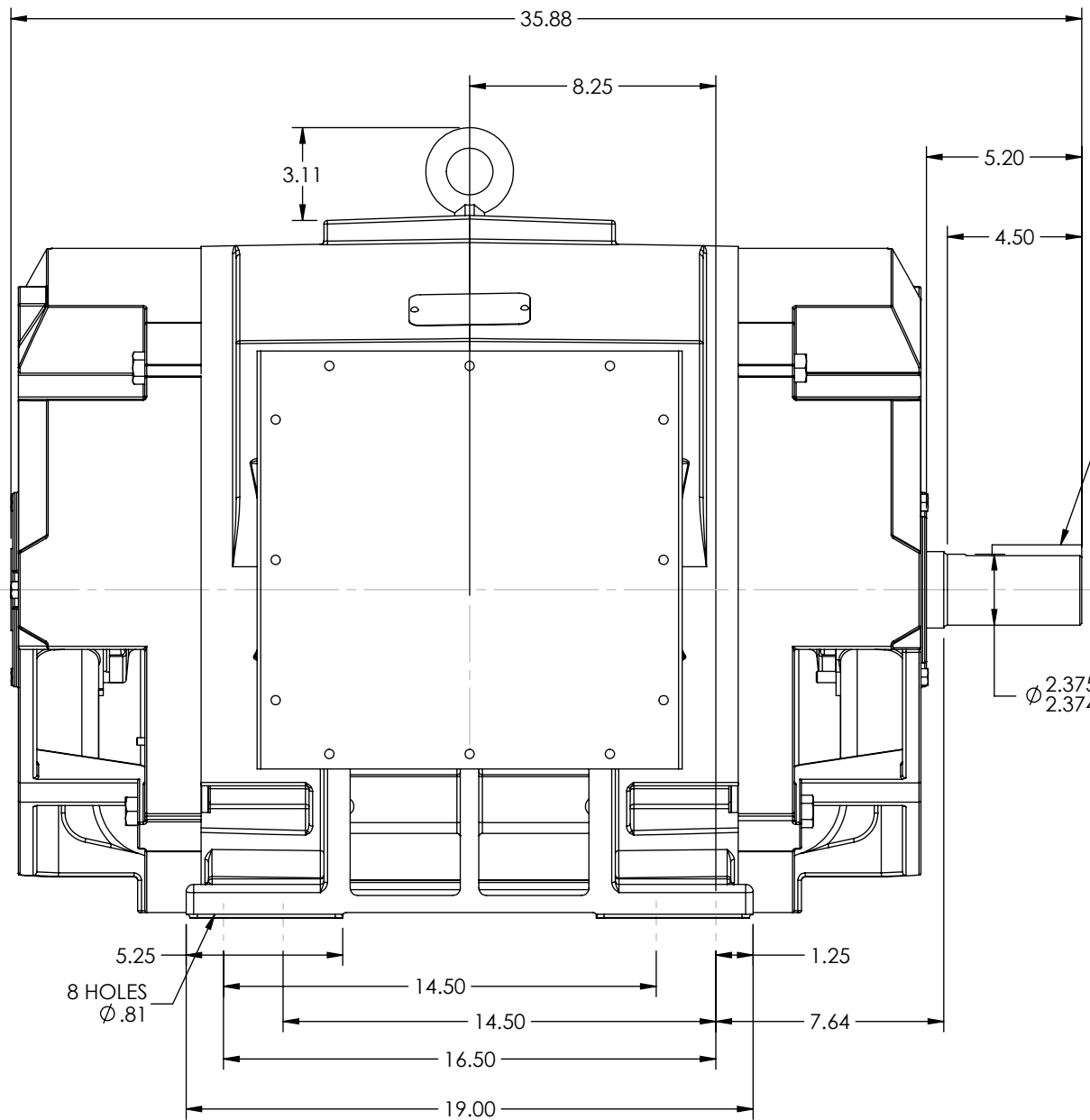

D

C

B

A

MAXIMUM PERMISSIBLE SHAFT RUNOUT WHEN MEASURED AT END OF STD. SHAFT EXTENSION IS .002 T.I.R. UP TO AND INCLUDING 1.625 DIA. AND .003 T.I.R. 1.625 DIA. TO 5 INCH DIA.

WEIGHT (LBS): 444TS = 1710
445TS = 1750

MOTOR WEIGHTS MAY VARY BY 15% DEPENDING UPON RATING.

CUSTOMER IS RESPONSIBLE FOR DETERMINING THAT BALDOR'S PRODUCT WILL PERFORM SUITABLY IN THE INTENDED APPLICATION

REV. DESC: NEW			
REV: -	VERSION: 00	REVISED: 11:15:08 09/01/2016	TDR: 000000992285
MODEL NO. 617428-109			REF:
BY: RAGBXN			B

BALDOR

DIM SHEET HOR 444-445TS PROT SV FT - 14X14X12 FAB STEEL CBOX

617428-109

8

7

6

5

4

3

2

1

8

7

6

5

4

3

2

1