

ABB BALDOR RELIANCE III

Customer information packet

ENCP83581T-4

1HP, 1775RPM, 3PH, 60HZ, 143T, 0524M, TENV, F1

Class - CLI GP A,B,C,D

Division - Division II

Specifications

Enclosure	TENV
Frame	143T
Frame Material	Iron
Frequency	60.00 Hz
Haz Area Class and Group	CLI GP A,B,C,D
Haz Area Division	Division II
Motor Letter Type	Three Phase
Output @ Frequency	1.000 HP @ 60 HZ
Phase	3
Synchronous Speed @ Frequency	1800 RPM @ 60 HZ
Voltage @ Frequency	460.0 V @ 60 HZ
Agency Approvals	CCSA US CSA EEV NEMA PREMIUM NEMA_PREMIUM UR
Ambient Temperature	40 °C
Auxiliary Box	NO AUXILLARY BOX
Auxiliary Box Lead Termination	None
Base Indicator	Rigid
Bearing Grease Type	Polyrex EM (-20F +300F)
Blower	None
Constant Torque Speed Range	1.2
Current @ Voltage	1.500 A @ 460.0 V
Design Code	B
Drip Cover	No Drip Cover
Duty Rating	CONT
Efficiency @ 100% Load	87.5 %
Electrically Isolated Bearing	Not Electrically Isolated
Feedback Device	NO FEEDBACK
Front Shaft Indicator	None
Haz Area Temp Code	T4

Part Detail

Revision	A
Type	AC
Mech. spec.	05E276
Base	
Status	PRD/A
Elec. spec.	05WGX611
Layout	05LYE276
Eff. date	02-20-2023
CD Diagram	CD0006
Poles	04
Leads	3#18
Proprietary	False
Created date	03-11-2022

Heater Indicator	No Heater
High Voltage Full Load Amps	1.5 a
Insulation Class	F
Inverter Code	Inverter Ready
KVA Code	N
Lifting Lugs	Standard Lifting Lugs
Locked Bearing Indicator	Locked Bearing
Max Speed	2700 rpm
Motor Lead Quantity/Wire Size	3 @ 18 AWG
Motor Lead Termination	Ring Terminals
Motor Standards	NEMA
Motor Type	0524M
Mounting Arrangement	F1
Number of Poles	4
Overall Length	11.37 IN
Power Factor	72
Product Family	Chem Process S/P 32-8 IEEE 841
Pulley End Bearing Type	Ball
Pulley Face Code	Standard
Pulley Shaft Indicator	Standard
Rodent Screen	None
Service Factor	1.15
Shaft Diameter	0.875 IN
Shaft Ground Indicator	No Shaft Grounding
Shaft Rotation	Reversible
Shaft Slinger Indicator	No Slinger
Speed	1775 rpm
Speed Code	Single Speed
Starting Method	Direct on line
Thermal Device - Bearing	None
Thermal Device - Winding	None
Vibration Sensor Indicator	No Vibration Sensor
Winding Thermal 1	None
Winding Thermal 2	None

Nameplate

NP4328									
CAT.NO.	ENCP83581T-4								
SPEC.	05E276X611G1								
HP	1 TE		IP	56					
VOLTS	460								
AMPS	1.5								
R.P.M.	1775								
FRAME	143T		HZ	60		PH	3		
SER.F.	1.15	CODE	N	DES.	B	CLASS	F		
RATING	40C AMB-CONT								
SN									
DE	6205	ODE	6203						
NEMA NOM. EFF.	87.5	P.F.	72						
GUAR. MIN. EFF.	85.5	CC	010A						
T. CODE	T4	TEMP=	135						

NP3186

SPEC.	05E276X611G1		
ABMA DE BRG	25BC02X30X		
ABMA ODE BRG	17BC02XP30X		
GREASE	POLYREX EM		
MOTOR WEIGHT	60	ROTOR BARS	27
		STATOR BARS	36
MAX. R.P.M.	2700	MAX. KVAR	0.4
	SFA 1.6		
INV.TYPE	PWM		
T=	135		
CHP	60	TO	90
CT	1.2	TO	60
VT	-0	TO	60
HTR-VOLTS		HTR-AMPS	
HTR-WATTS		MAX. SPACE HEATER TEMP.	

ABB Motors and Mechanical Inc.

WINDING # 05WGX611

Typical performance - not guaranteed values.

1 HP 3 PH 60 HZ 1775 RPM 460 V 0524M

TORQUES (LB-FT): PO=14.24 PU=8.16 LR=9.46 LRA=14.67

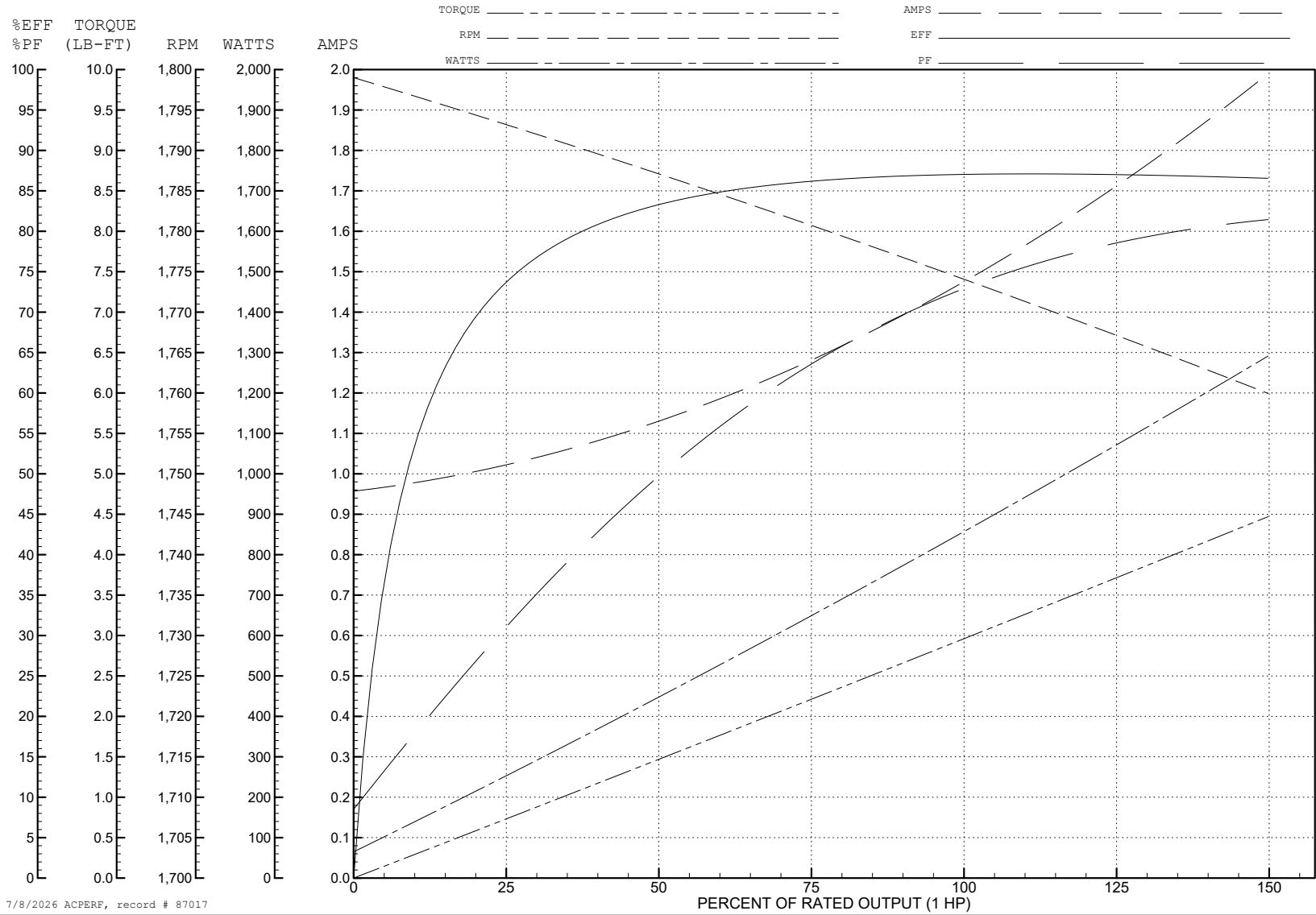

7/8/2026 ACPERF, record # 87017

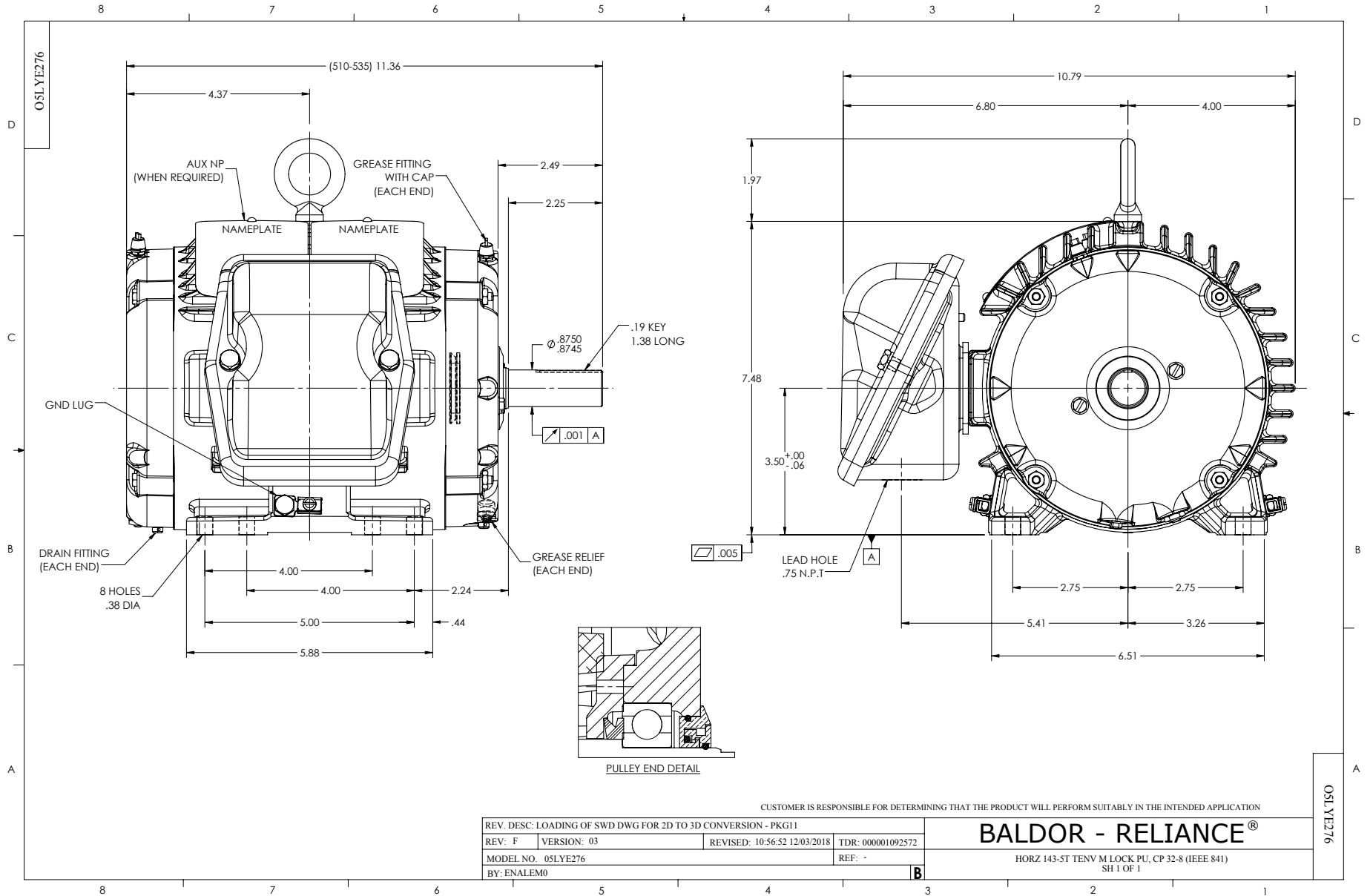

CD0006



NOTES:

1. THREE LEAD MOTOR MAY BE EITHER WYE CONNECTED OR DELTA CONNECTED.
2. INTERCHANGE ANY TWO LINE LEADS TO REVERSE ROTATION.
3. OPTIONAL THERMOSTATS ARE PROVIDED WHEN SPECIFIED.
4. ACTUAL NUMBER OF INTERNAL PARALLEL CIRCUITS MAY VARY.
5. LEAD COLORS ARE OPTIONAL. LEADS MUST BE NUMBERED AS SHOWN.

CD0006

REV. DESC: ADD CLASS CONN00000007		
REV. LTR: E	VERSION: 01	TDR: 000001099922
FILE: \AAA\00005\141	REVISED: 10:24:49 02/19/2019	BY: ENBRIRO
MTL: -		© □

BALDOR - RELIANCE®

3PH, SV, 3 LEADS, WYE OR DELTA CONNECTED

SH 1 of 1