

**BALDOR® • RELIANCE™**

---

# Customer information packet

## EM4410TR-4

125HP, 1785RPM, 3PH, 60HZ, 444T, A44076M, TEFC

Class - None

Division - Not Applicable

Copyright © All product information within this document is subject to ABB Motors and Mechanical Inc. copyright © protection, unless otherwise noted.

9/9/2024 7:00:46 AM

## Specifications

Enclosure	TEFC
Frame	444T
Frame Material	Iron
Frequency	60.00 Hz
Haz Area Class and Group	None
Haz Area Division	Not Applicable
Motor Letter Type	Three Phase
Output @ Frequency	125.000 HP @ 60 HZ
Phase	3
Synchronous Speed @ Frequency	1800 RPM @ 60 HZ
Voltage @ Frequency	460.0 V @ 60 HZ
Agency Approvals	CCSAUSEEV
Ambient Temperature	40 °C
Auxillary Box	No Auxillary Box
Base Indicator	Rigid
Bearing Grease Type	Mobil SHC 220 (Athens Only)
Current @ Voltage	144.000 A @ 460.0 V
Design Code	B
Drip Cover	No Drip Cover
Duty Rating	CONT
Efficiency @ 100% Load	95.4 %
Feedback Device	NO FEEDBACK
Heater Indicator	No Heater
High Voltage Full Load Amps	144.0 a
Insulation Class	F
Inverter Code	Inverter Ready
KVA Code	G
Lifting Lugs	Standard Lifting Lugs
Motor Lead Quantity/Wire Size	3 @ 1/0 AWG
Motor Standards	NEMA
Motor Type	A44076M
Mounting Arrangement	F1

## Part detail

Revision	Q
Type	AC
Mech. spec.	
Base	
Status	PRD/A
Elec. spec.	A44WG3870
Layout	617427-001
Eff. date	09-04-2024
CD Diagram	416820-036
Poles	04
Leads	3#1/0
Proprietary	False
Created date	02-19-2013

<b>Number of Poles</b>	4
<b>Overall Length</b>	44.75 IN
<b>Power Factor</b>	85
<b>Product Family</b>	Other
<b>Pulley End Bearing Type</b>	Roller
<b>Pulley Face Code</b>	Standard
<b>Service Factor</b>	1.15
<b>Shaft Diameter</b>	3.375 IN
<b>Shaft Ground Indicator</b>	No Shaft Grounding
<b>Shaft Rotation</b>	Reversible
<b>Shaft Slinger Indicator</b>	No Slinger
<b>Speed</b>	1785 rpm
<b>Speed Code</b>	Single Speed
<b>Starting Method</b>	Direct on line
<b>Thermal Device - Bearing</b>	None
<b>Thermal Device - Winding</b>	None

**Nameplate**

**NP2349L**

<b>SPEC NO.</b>	P44G4027	<b>CAT.NO.</b>	EM4410TR-4	<b>FRAME</b>	444T
<b>HP</b>	125	<b>VOLTS</b>	460	<b>PHASE</b>	3
<b>RPM</b>	1785	<b>AMPS</b>	144	<b>HZ</b>	60
<b>DRIVE END BEARING</b>	110RU02M30X	<b>DUTY</b>	CONT	<b>INSUL.CLASS</b>	F
<b>OPP D.E. BEARING</b>	90BC03J30X	<b>ENCL</b>	TEFC	<b>CODE</b>	G
<b>SER.NO.</b>		<b>POWER FACTOR</b>	85	<b>NEMA-NOM-EFFICIENCY</b>	95.4
				<b>MAX CORR KVAR</b>	27
				<b>GUARANTEED EFFICIENCY</b>	94.5
				<b>NEMA NOM/CSA QUOTED EFF</b>	
				<b>MOTOR WEIGHT</b>	

---

**NP2496L**

---

MOBIL SHC 220 GREASE

---









617427-001

# DUTY MASTER ALTERNATING CURRENT MOTORS

## SQUIRREL-CAGE INDUCTION

ENCLOSURE: TOTALLY ENCLOSED

FRAME G445T ABOVE NEMA RATINGS

COOLING: FAN COOLED

MOUNTING: FOOT

INCLUDES 444T FRAME MOUNTING HOLES

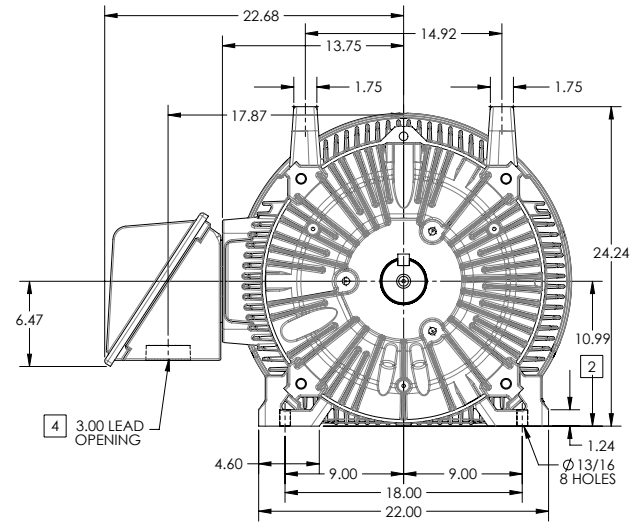
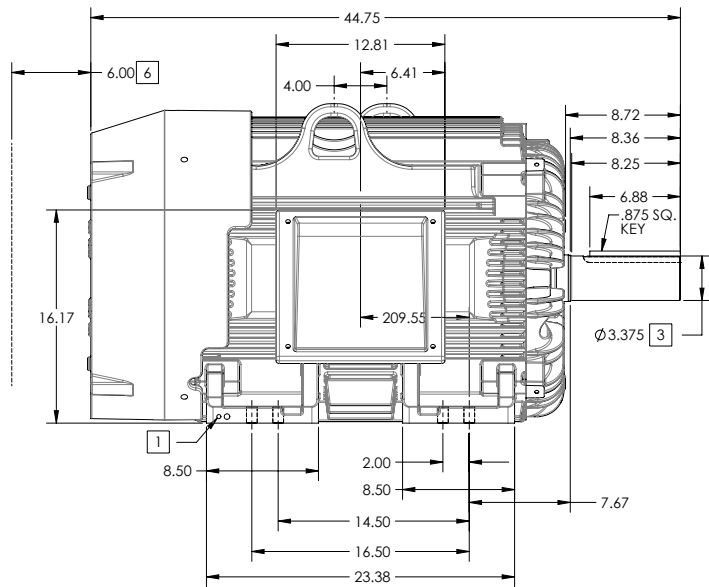

1. GROUND HOLES QTY 1 1/2-13 TAP; QTY 1 3/8-16 TAP
2. VARIES +.00,-.06
3. VARIES +.00,-.001
4. ON STANDARD MOTORS THIS IS CONDUIT SIZE. ON XT AND CORROSION PROOF MOTOR THIS IS PIPE TAP.
5. MOTOR WEIGHTS MAY VARY BY 15% DEPENDING ON RATING.
6. OBSTRUCTION MUST NOT ENCROACH ON AIR INLET

CONDUIT BOX LOCATED ON OPPOSITE SIDE WHEN F-2.  
IF MOUNTING CLEARANCE DETAILS ARE REQUIRED, CONSULT FACTORY.  
MAXIMUM PERMISSIBLE SHAFT RUNOUT WHEN MEASURED AT END OF STANDARD SHAFT EXTENSION IS .003" T.I.R. TO 5 INCH DIA.

**[5] WEIGHT (LBS): 2130**

DRIVE END AIR DEFLECTOR IS ONLY INCLUDED WHEN NECESSARY.

DIMENSIONS ARE IN INCHES; SEE SHEET 2 FOR DIMENSIONS IN MILLIMETERS

CUSTOMER IS RESPONSIBLE FOR DETERMINING THAT MOTOR PERFORMANCE IS SUITABLE IN THE APPLICATION.

SHEET NUMBER  
**1 OF 2**

100-272119

REV. DESC SHEET 2 NEEDS METRIC FOOT HOLE DIMENSION			
REV: E	VERSION: 05	REVISED: 09-22-56 06/12/2014	TDR: 00000857938
MODEL NO. 617427-001			REF:
BY: RAGRA	Material:		

**BALDOR**

G445T-444T STD - FOOTED - SIDE CENTER C/B

617427-001

# DUTY MASTER ALTERNATING CURRENT MOTORS

## SQUIRREL-CAGE INDUCTION

ENCLOSURE: TOTALLY ENCLOSED

FRAME G445T ABOVE NEMA RATINGS

COOLING: FAN COOLED

MOUNTING: FOOT

INCLUDES 444T FRAME MOUNTING HOLES

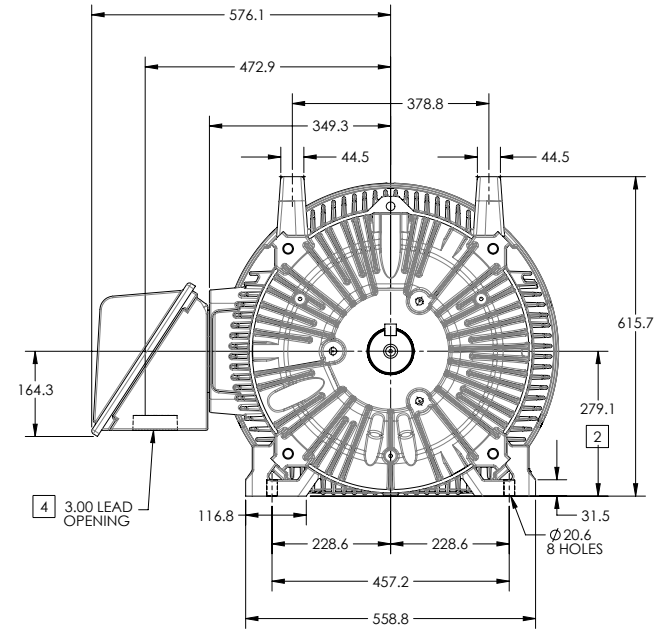
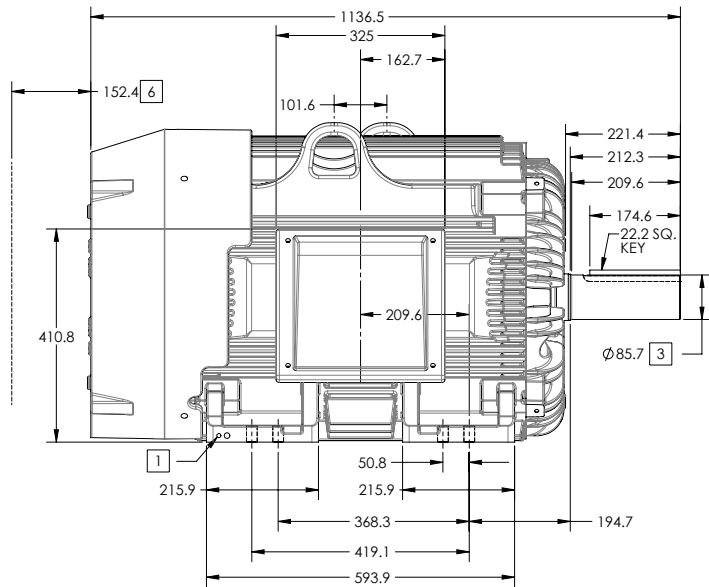

1. GROUND HOLES QTY 1 1/2-13 TAP; QTY 1 3/8-16 TAP
2. VARIES +0,-1.5
3. VARIES +00,-.03
4. ON STANDARD MOTORS THIS IS CONDUIT SIZE. ON XT AND CORROSION PROOF MOTOR THIS IS PIPE TAP.
5. MOTOR WEIGHTS MAY VARY BY 15% DEPENDING ON RATING.
6. OBSTRUCTION MUST NOT ENCROACH ON AIR INLET

**[5] WEIGHT (KGS): 970**

DRIVE END AIR DEFLECTOR IS ONLY INCLUDED WHEN NECESSARY.

DIMENSIONS ARE IN MILLIMETERS; SEE SHEET 1 FOR DIMENSIONS IN INCHES

CUSTOMER IS RESPONSIBLE FOR DETERMINING THAT MOTOR PERFORMANCE IS SUITABLE IN THE APPLICATION.

CONDUIT BOX LOCATED ON OPPOSITE SIDE WHEN F-2.  
IF MOUNTING CLEARANCE DETAILS ARE REQUIRED, CONSULT FACTORY.  
MAXIMUM PERMISSIBLE SHAFT RUNOUT WHEN MEASURED AT END OF STANDARD SHAFT EXTENSION IS .08 MM T.I.R. TO 127 MM DIA.

SHEET NUMBER  
**2 OF 2**

100-LCFL19

REV. DESC SHEET 2 NEEDS METRIC FOOT HOLE DIMENSION			
REV: E	VERSION: 05	REVISED: 09-22-56 06/12/2014	TDR: 00000857938
MODEL NO. 617427-001			REF:
BY: RAGRA	Material:		

**BALDOR**

G445T444T STD - FOOTED - SIDE CENTER C/B

416820-036

A-C MOTOR  
CONNECTION DIAGRAM  
STANDARD 3 LEAD CONNECTED



(N.P. 1575-BA)

416820-036

REV. DESC: LOADED TO BUS, C/R 335225		
REV. LTR: -	VERSION: 00	TDR: 000000538207
FILE: \MGA\00000\682	REVISED: 11:54:06 04/30/2010	
MTL: -	BY: RAGRA	

**BALDOR**

CONN DIAG - STANDARD 3 LEAD  
SH 1 of 1