



Customer information packet

EM4110T-G

40HP, 1775RPM, 3PH, 60HZ, 324T, 1254M, TEFC, F1

Class - None

Division - Not Applicable

Specifications

Enclosure	TEFC
Frame	324T
Frame Material	Iron
Frequency	60.00 Hz
Motor Letter Type	Three Phase
Output @ Frequency	40.000 HP @ 60 HZ
Phase	3
Synchronous Speed @ Frequency	1800 RPM @ 60 HZ
Voltage @ Frequency	460.0 V @ 60 HZ 230.0 V @ 60 HZ
XP Class and Group	None
XP Division	Not Applicable
Agency Approvals	CSA CSA EEV UR
Ambient Temperature	40 °C
Auxillary Box	No Auxillary Box
Auxillary Box Lead Termination	None
Base Indicator	Rigid
Bearing Grease Type	Polyrex EM (-20F +300F)
Blower	None
Current @ Voltage	48.000 A @ 460.0 V 96.000 A @ 230.0 V 102.000 A @ 208.0 V
Design Code	A
Drip Cover	No Drip Cover
Duty Rating	CONT
Efficiency @ 100% Load	94.1 %
Electrically Isolated Bearing	Not Electrically Isolated
Feedback Device	NO FEEDBACK
Front Face Code	Standard
Front Shaft Indicator	None

Part detail

Revision	T
Type	AC
Mech. spec.	12F882
Base	
Status	PRD/A
Elec. spec.	12WGY276
Layout	12LYF882
Eff. date	08-01-2023
CD Diagram	CD0180
Poles	04
Leads	9#8
Proprietary	False
Created date	06-06-2013

Heater Indicator	No Heater
High Voltage Full Load Amps	48.0 a
Insulation Class	H
Inverter Code	Inverter Ready
KVA Code	H
Lifting Lugs	Standard Lifting Lugs
Locked Bearing Indicator	Locked Bearing
Motor Lead Exit	Ko Box
Motor Lead Quantity/Wire Size	9 @ 8 AWG
Motor Lead Termination	Flying Leads
Motor Standards	NEMA
Motor Type	1254M
Mounting Arrangement	F1
Number of Poles	4
Overall Length	30.28 IN
Power Factor	82
Product Family	General Purpose
Pulley End Bearing Type	Ball
Pulley Face Code	Standard
Pulley Shaft Indicator	Standard
Rodent Screen	None
Service Factor	1.15
Shaft Diameter	2.125 IN
Shaft Extension Location	Pulley End
Shaft Ground Indicator	Shaft Grounding
Shaft Rotation	Reversible
Shaft Slinger Indicator	Shaft Slinger
Speed	1775 rpm
Speed Code	Single Speed
Starting Method	Direct on line
Thermal Device - Bearing	NONE (OLD)
Thermal Device - Winding	None
Vibration Sensor Indicator	No Vibration Sensor
Winding Thermal 1	None

Winding Thermal 2

None

Nameplate

NP3443LUA

CAT.NO.	EM4110T-G			CUST. P/N			ENCL	TEFC
SPEC.	12F882Y276G1	CC	010A	FRAME	324T		SER.NO.	
HP	40	CLASS	H	HZ	60			
R.P.M.	1775	PH.	3	DES.	A			
VOLTS	230/460	CODE	H	ODE BRG	6311	DE BRG	6312	
AMPS	96/48	USABLE AT 208V	N/A					
RATING	40C AMB-CONT	NEMA NOM. EFF.	94.1	GREASE	POLYREX EM			
P.F.	82	SER.F.	1.15	CT6-60H(10:1)VT3-60H(20:1)				
USABLE AT	50HZ 40HP 190/380V 114/57A			SF1.0				
VOLTS	AMPS	MAX. SPACE HEATER TEMP.						

AC Induction Motor Performance Data

Record # 48204

Typical performance - not guaranteed values

Winding: 12WGY276-R010		Type: 1254M		Enclosure: TEFC	
Nameplate Data			460 V, 60 Hz: High Voltage Connection		
Rated Output (HP)	40	Full Load Torque	118 LB-FT		
Volts	230/460	Start Configuration	direct on line		
Full Load Amps	96/48	Breakdown Torque	386 LB-FT		
R.P.M.	1775	Pull-up Torque	193 LB-FT		
Hz	60 Phase	3	Locked-rotor Torque	216 LB-FT	
NEMA Design Code	A KVA Code	H	Starting Current	338 A	
Service Factor (S.F.)	1.15		No-load Current	19.9 A	
NEMA Nom. Eff.	94.1	Power Factor	82	Line-line Res. @ 25°C	0.14898 Ω
Rating - Duty	40C AMB-CONT		Temp. Rise @ Rated Load	54°C	
S.F. Amps			Temp. Rise @ S.F. Load	64°C	
			Locked-rotor Power Factor	27	
			Rotor inertia	7.19 LB-FT ²	

Load Characteristics 460 V, 60 Hz, 40 HP

% of Rated Load	25	50	75	100	125	150	S.F.
Power Factor	47	69	78	83	85	85	84
Efficiency	90.1	93.5	94.2	94.2	93.8	93.1	94
Speed	1793.5	1788	1782.5	1776.6	1770.7	1764.1	1773
Line amperes	22.9	29.5	38.4	48.1	59.2	70.8	54.8

ABB Motors and Mechanical Inc.

WINDING # 12WGY276

Typical performance - not guaranteed values.

40 HP 3 PH 60 HZ 1775 RPM 460 V 1254M

TORQUES (LB-FT): PO=386 PU=193 LR=216 LRA=338

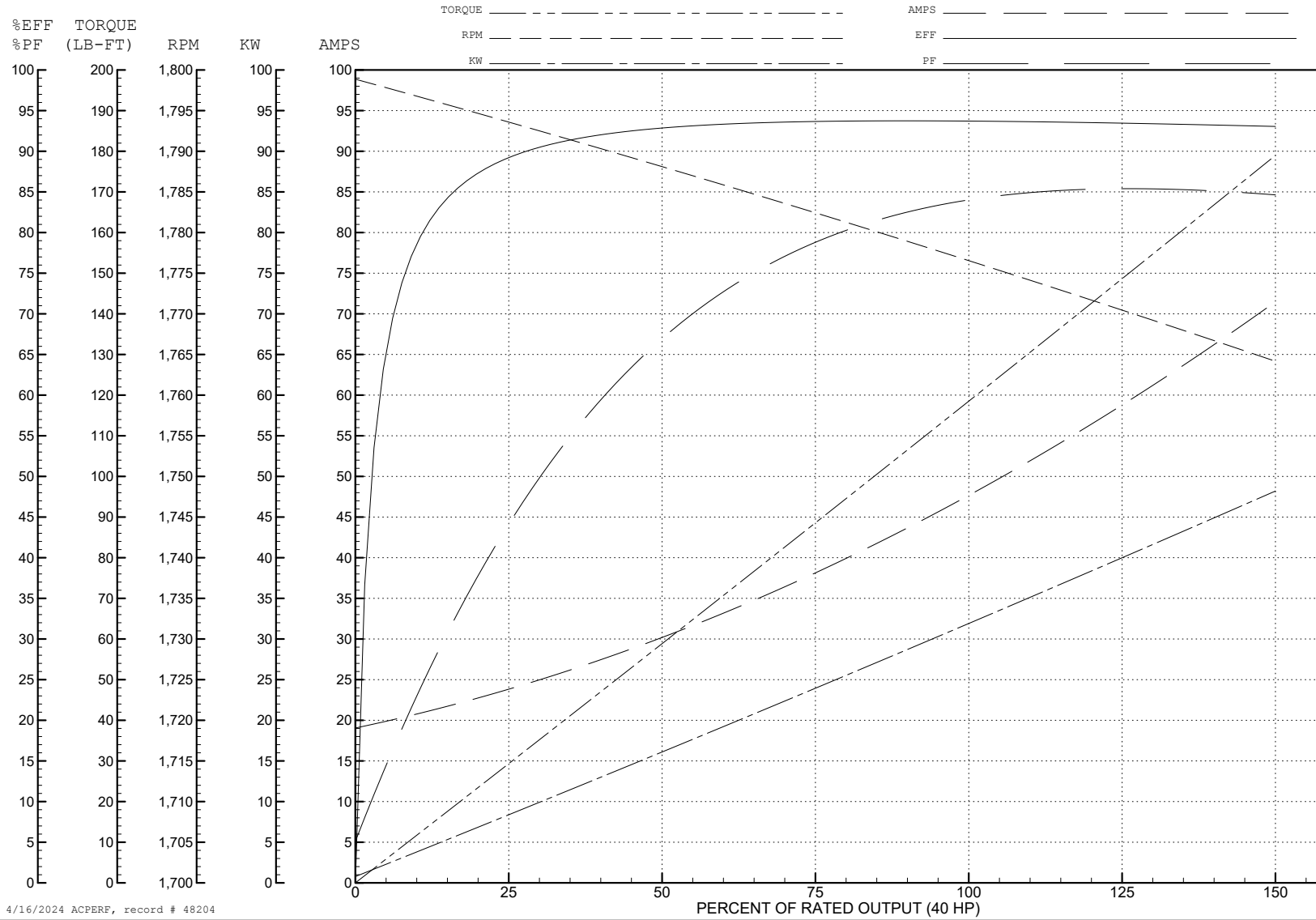

4/16/2024 ACPERF, record # 48204

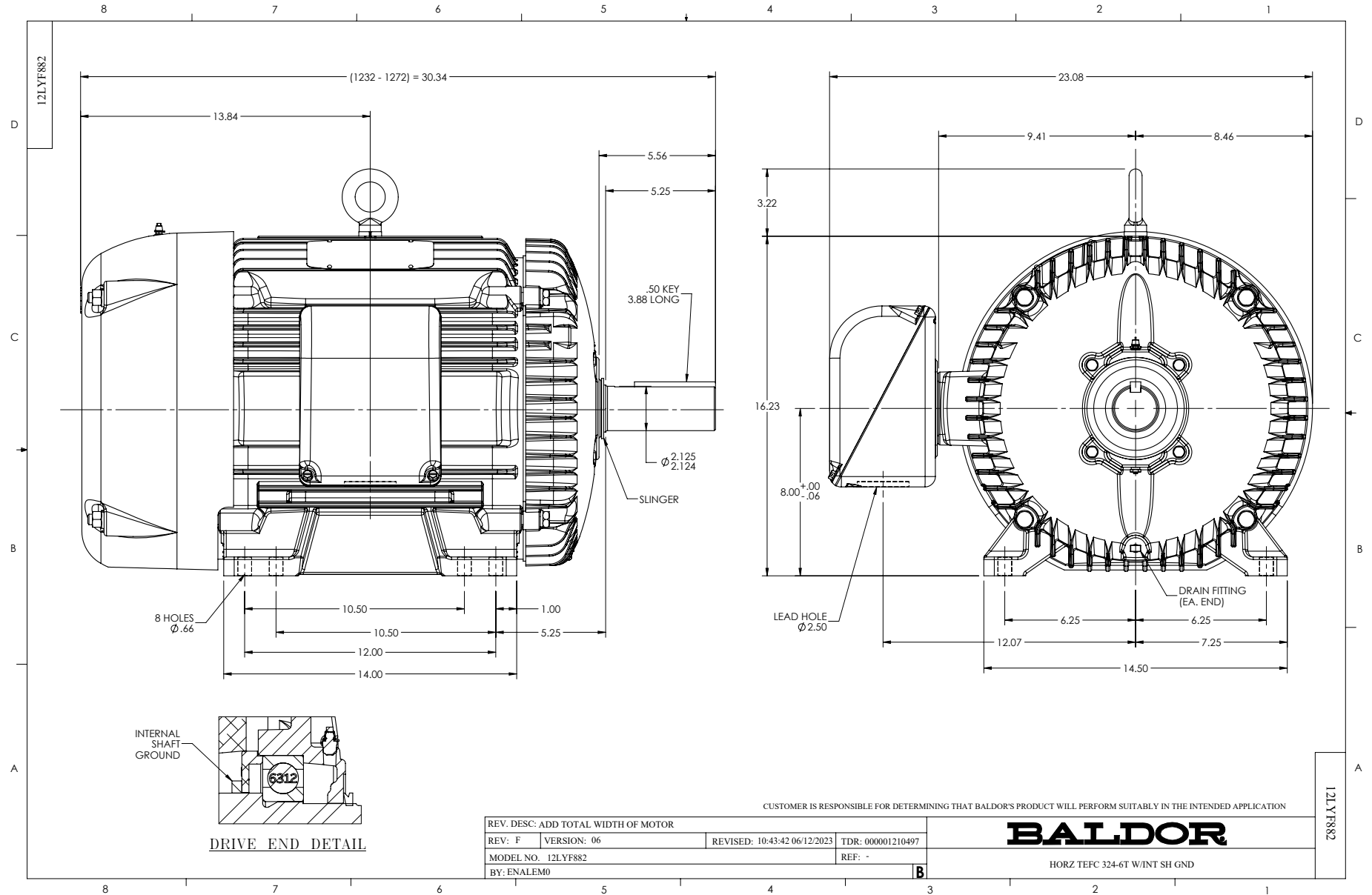

CD0180

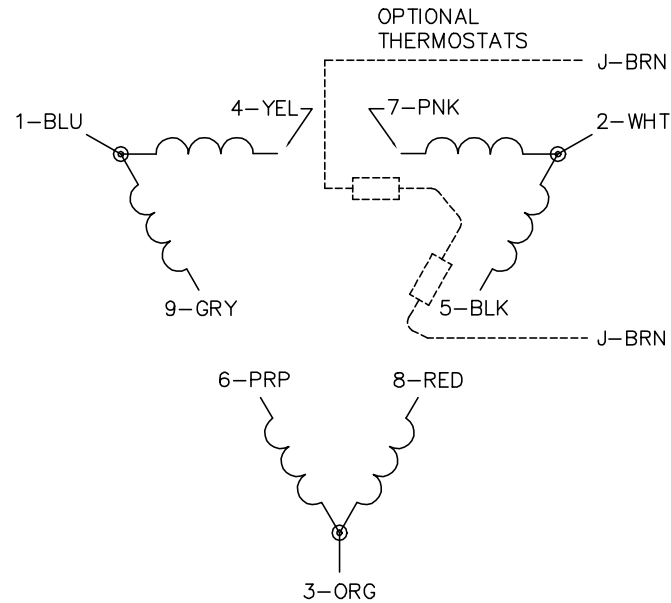

LOW VOLTAGE
(2D)



HIGH VOLTAGE
(1D)



NOTES:

1. INTERCHANGE ANY TWO LINE LEADS TO REVERSE ROTATION.
2. OPTIONAL THERMOSTATS ARE PROVIDED WHEN SPECIFIED.
3. ACTUAL NUMBER OF INTERNAL PARALLEL CIRCUITS MAY BE A MULTIPLE OF THOSE SHOWN ABOVE.
4. LEAD COLORS ARE OPTIONAL. LEADS MUST ALWAYS BE NUMBERED AS SHOWN.

CD0180

REV. DESC: ADD CLASS CONN00000007		
REV. LTR: D	VERSION: 01	TDR: 000001099922
FILE: \AAA\00005\148	REVISED: 10: 25: 29 02/19/2019	BY: ENBRIRO
MTL: -	© □	

BALDOR - RELIANCE®

3PH, DV, 9 LEADS, DELTA CONNECTION

SH 1 of 1