

**BALDOR • RELIANCE**

---

# Customer information packet

## EM3661T-5

32M 4P TEFC HOR 182T SUPER E

Class - None

Division - Not Applicable

## Specifications

Enclosure	TEFC
Frame	182T
Frame Material	Iron
Frequency	60.00 Hz
Haz Area Class and Group	None
Haz Area Division	Not Applicable
Motor Letter Type	Three Phase
Output @ Frequency	3.000 HP @ 60 HZ
Phase	3
Synchronous Speed @ Frequency	1800 RPM @ 60 HZ
Voltage @ Frequency	575.0 V @ 60 HZ
Agency Approvals	NEMA PREMIUM CURUSEEV
Ambient Temperature	40 °C
Auxiliary Box	NO AUXILLARY BOX
Auxiliary Box Lead Termination	None
Base Indicator	Rigid
Bearing Grease Type	Polyrex EM (-20F +300F)
Blower	None
Current @ Voltage	3.300 A @ 575.0 V
Design Code	B
Drip Cover	No Drip Cover
Duty Rating	CONT
Efficiency @ 100% Load	89.5 %
Electrically Isolated Bearing	Not Electrically Isolated
Feedback Device	NO FEEDBACK
Front Shaft Indicator	None
Heater Indicator	No Heater
High Voltage Full Load Amps	3.3 a
Insulation Class	F
Inverter Code	Inverter Ready
IP Rating	NONE

## Part detail

Revision	E
Type	AC
Mech. spec.	06C101
Base	
Status	PRD/A
Elec. spec.	06WGX319
Layout	06LYC101
Eff. date	08-05-2024
CD Diagram	CD0006
Poles	04
Leads	3#16
Proprietary	False
Created date	12-14-2018

<b>KVA Code</b>	J
<b>Lifting Lugs</b>	Standard Lifting Lugs
<b>Locked Bearing Indicator</b>	No Locked Bearing
<b>Motor Lead Quantity/Wire Size</b>	3 @ 16 AWG
<b>Motor Lead Termination</b>	Flying Leads
<b>Motor Standards</b>	NEMA
<b>Motor Type</b>	0632M
<b>Mounting Arrangement</b>	F1
<b>Number of Poles</b>	4
<b>Overall Length</b>	15.24 IN
<b>Power Factor</b>	77
<b>Product Family</b>	General Purpose
<b>Pulley End Bearing Type</b>	Ball
<b>Pulley Face Code</b>	Standard
<b>Pulley Shaft Indicator</b>	Standard
<b>Rodent Screen</b>	None
<b>RoHS Status</b>	ROHS COMPLIANT
<b>Service Factor</b>	1.15
<b>Shaft Diameter</b>	1.125 IN
<b>Shaft Ground Indicator</b>	No Shaft Grounding
<b>Shaft Rotation</b>	Reversible
<b>Shaft Slinger Indicator</b>	No Slinger
<b>Speed</b>	1755 rpm
<b>Speed Code</b>	Single Speed
<b>Starting Method</b>	Direct on line
<b>Thermal Device - Bearing</b>	None
<b>Thermal Device - Winding</b>	None
<b>Vibration Sensor Indicator</b>	No Vibration Sensor
<b>Winding Thermal 1</b>	None
<b>Winding Thermal 2</b>	None

**Nameplate**

<b>NP3441L</b>									
<b>CAT.NO.</b>	EM3661T-5								
<b>SPEC.</b>	06C101X319G1								
<b>HP</b>	3								
<b>VOLTS</b>	575								
<b>AMP</b>	3.3								
<b>RPM</b>	1755								
<b>FRAME</b>	182T		<b>HZ</b>	60		<b>PH</b>	3		
<b>SER.F.</b>	1.15	<b>CODE</b>	J	<b>DES</b>	B	<b>CL</b>	F		
<b>NEMA-NOM-EFF</b>	89.5	<b>PF</b>	77						
<b>RATING</b>	40C AMB-CONT								
<b>CC</b>	010A								
<b>DE</b>	6206		<b>ODE</b>	6205					
<b>ENCL</b>	TEFC	<b>SN</b>							
<b>VPWM INVERTER READY</b>									
<b>CT6-60H(10:1)VT3-60H(20:1</b>									
	SFA 3.5								

**Accessories**

<b>Part number</b>	<b>Description</b>	<b>Multiplier</b>
36-1749	C FACE KIT	A8

**AC Induction Motor Performance Data**

Record # 75292

Typical performance - not guaranteed values

Winding: 06WGX319-R001		Type: 0632M	Enclosure: TEFC		
<b>Nameplate Data</b>			<b>460 V, 60 Hz: Single Voltage Motor</b>		
Rated Output (HP)	3	Full Load Torque	9.17 LB-FT		
Volts	575	Start Configuration	direct on line		
Full Load Amps	3.3	Breakdown Torque	20.9 LB-FT		
R.P.M.	1755	Pull-up Torque	11.4 LB-FT		
Hz	60 Phase	3	Locked-rotor Torque	12.71 LB-FT	
NEMA Design Code	B	KVA Code	J	Starting Current	18.81 A
Service Factor (S.F.)	1.15	No-load Current	1.29 A		
NEMA Nom. Eff.	89.5	Power Factor	77	Line-line Res. @ 25°C	6.2 Ω
Rating - Duty	40C AMB-CONT		Temp. Rise @ Rated Load	41°C	
S.F. Amps			Temp. Rise @ S.F. Load	54°C	
			Locked-rotor Power Factor	41.1	
			Rotor inertia	0.298 LB-FT <sup>2</sup>	

**Load Characteristics 460 V, 60 Hz, 3 HP**

% of Rated Load	25	50	75	100	125	150	S.F.
Power Factor	54	74	81	84	85	84	85
Efficiency	86.9	89.6	89.6	88.1	86.2	83.1	87
Speed	1785	1769	1753	1734	1711	1684	1720
Line amperes	1.57	2.17	2.94	3.81	4.83	6.1	4.42

ABB Motors and Mechanical Inc.

WINDING # 06WGX319

3 HP 3 PH 60 HZ 1755 RPM 460 V 0632M

Typical performance - not guaranteed values.

TORQUES (LB-FT): PO=20.9 PU=11.4 LR=12.71 LRA=18.81

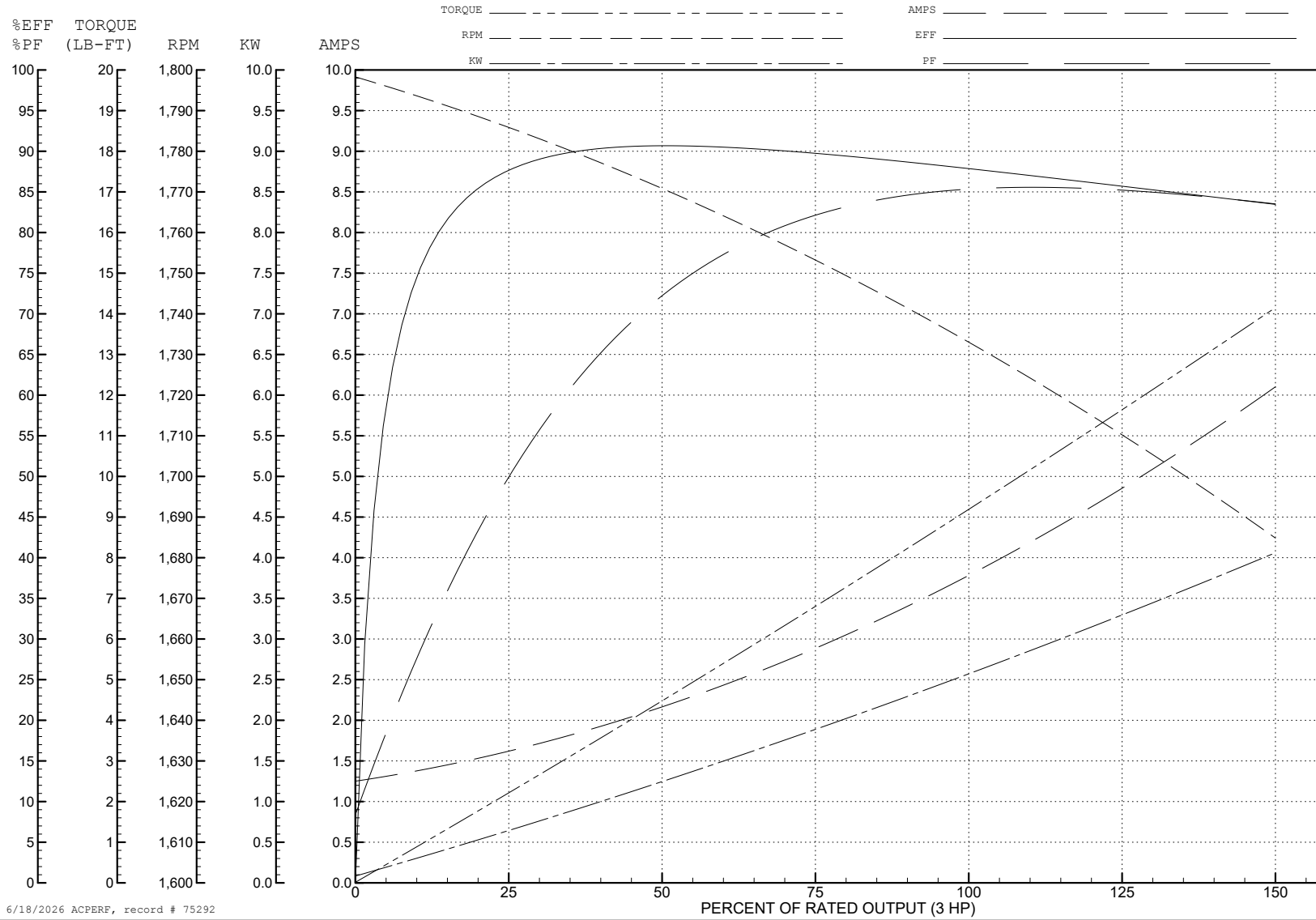

6/18/2026 ACPERF, record # 75292

**AC Induction Motor Performance Data**

Record # 84796

Typical performance - not guaranteed values

Winding: 06WGX319-R001		Type: 0632M	Enclosure: TEFC	
<b>Nameplate Data</b>			<b>575 V, 60 Hz: Single Voltage Motor</b>	
Rated Output (KW)	2.2	Full Load Torque	12.21 N-M	
Volts	575	Start Configuration	direct on line	
Full Load Amps	3.3	Breakdown Torque	28.35 N-M	
R.P.M.	1755	Pull-up Torque	15.46 N-M	
Hz	60 Phase	3	Locked-rotor Torque	17.23 N-M
NEMA Design Code	B KVA Code	J	Starting Current	18.81 A
Service Factor (S.F.)		1.15	No-load Current	1.29 A
NEMA Nom. Eff.	89.5 Power Factor	77	Line-line Res. @ 25°C	6.2 Ω
Rating - Duty	40C AMB-CONT		Temp. Rise @ Rated Load	40°C
S.F. Amps			Temp. Rise @ S.F. Load	48°C
			Locked-rotor Power Factor	41.5
			Rotor inertia	0.0126 kg-m <sup>2</sup>

**Load Characteristics 575 V, 60 Hz, 2.2 KW**

% of Rated Load	25	50	75	100	125	150	S.F.
Power Factor	43	59	65	67	68	67	68
Efficiency	86.7	89.8	89.5	88.1	86.3	83.1	87
Speed	1785	1769	1753	1735	1713	1685	1722
Line amperes	1.56	2.16	2.91	3.76	4.75	6	4.35

ABB Motors and Mechanical Inc.

WINDING # 06WGX319

Typical performance - not guaranteed values.

2.2 KW 3 PH 60 HZ 1755 RPM 575 V 0632M

TORQUES (N-M) : PO=28.35 PU=15.46 LR=17.23 LRA=18.81

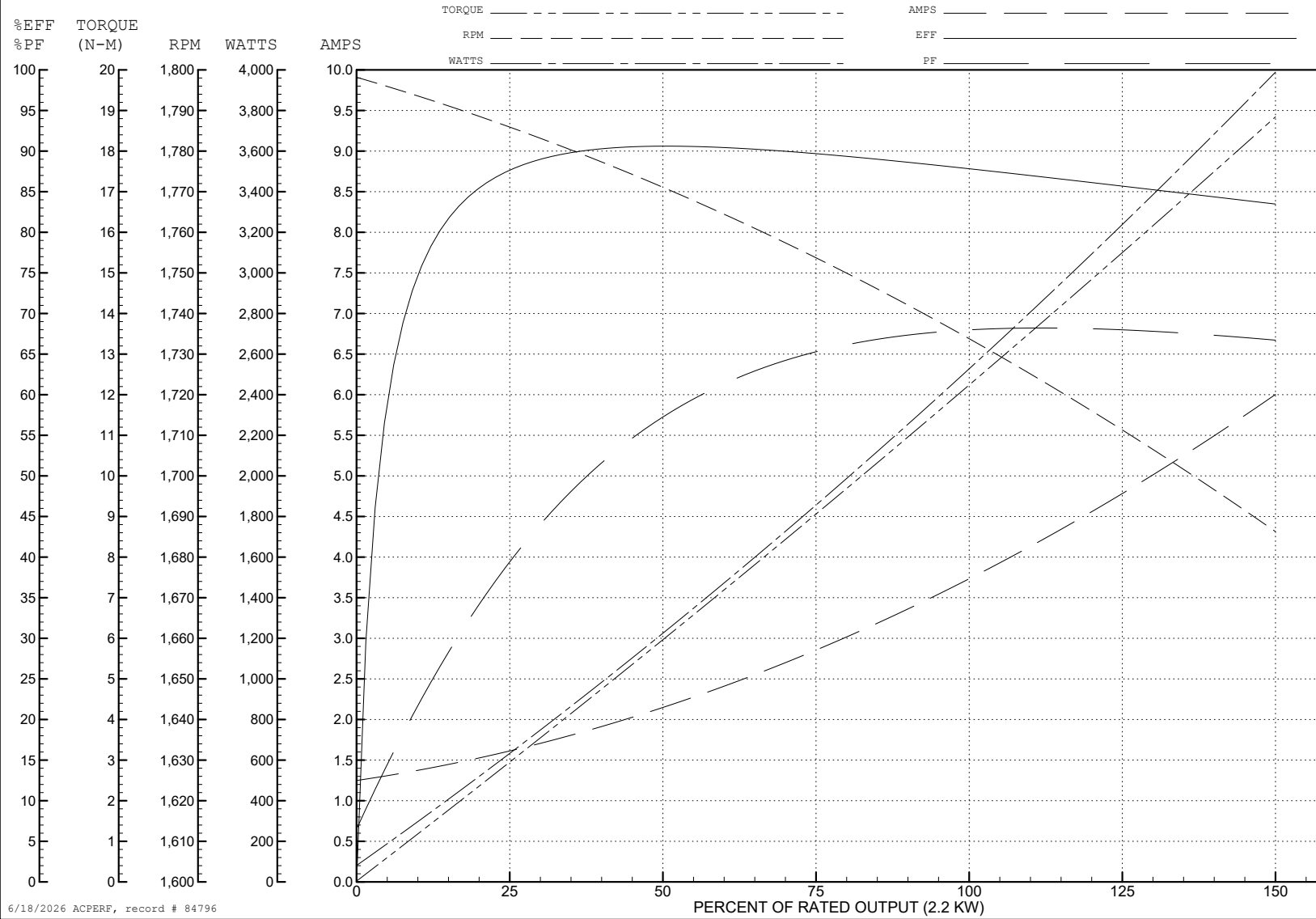

6/18/2026 ACPERF, record # 84796

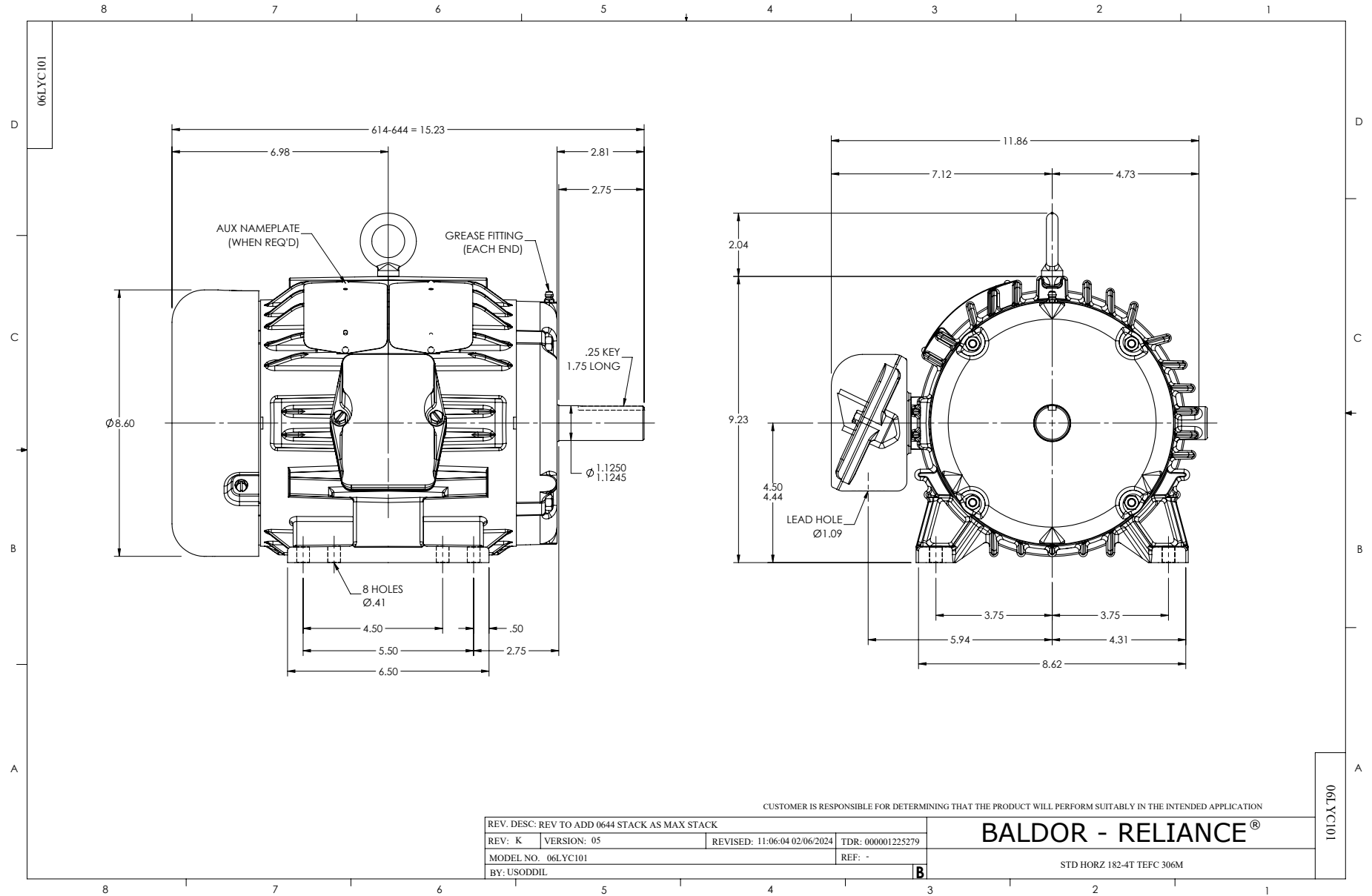

CD0006

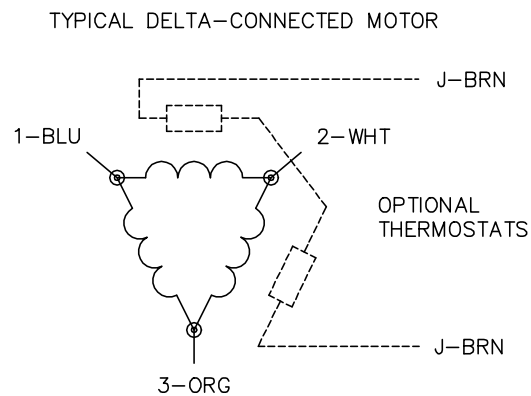
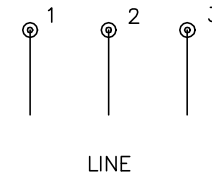
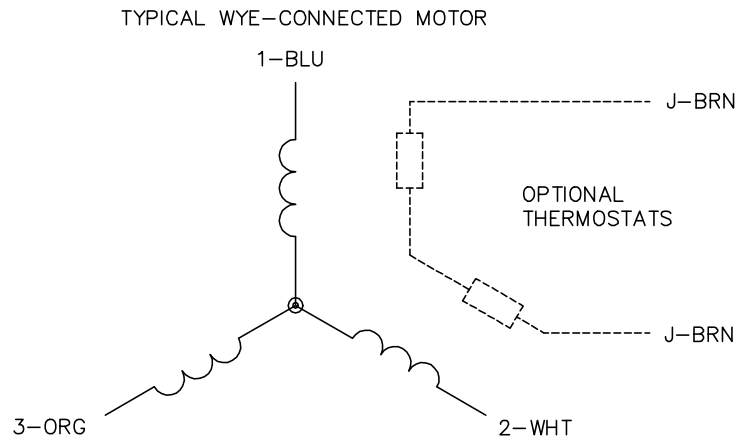

NOTES:

1. THREE LEAD MOTOR MAY BE EITHER WYE CONNECTED OR DELTA CONNECTED.
2. INTERCHANGE ANY TWO LINE LEADS TO REVERSE ROTATION.
3. OPTIONAL THERMOSTATS ARE PROVIDED WHEN SPECIFIED.
4. ACTUAL NUMBER OF INTERNAL PARALLEL CIRCUITS MAY VARY.
5. LEAD COLORS ARE OPTIONAL. LEADS MUST BE NUMBERED AS SHOWN.

CD0006

REV. DESC: ADD CLASS CONN00000007		
REV. LTR: E	VERSION: 01	TDR: 000001099922
FILE: \AAA\00005\141	REVISED: 10:24:49 02/19/2019	BY: ENBRIRO
MTL: -	© □	

**BALDOR - RELIANCE®**

3PH, SV, 3 LEADS, WYE OR DELTA CONNECTED

SH 1 of 1