

ABB BALDOR RELIANCE III

Customer information packet

EJMM2394T-5

15HP, 3490RPM, 3PH, 60HZ, 254JM, 0750M, TEFC, F

Class - None

Division - Not Applicable

Specifications

Enclosure	TEFC
Frame	254JM
Frame Material	Iron
Frequency	60.00 Hz
Haz Area Class and Group	None
Haz Area Division	Not Applicable
Motor Letter Type	Three Phase
Output @ Frequency	15.000 HP @ 60 HZ
Phase	3
Synchronous Speed @ Frequency	3600 RPM @ 60 HZ
Voltage @ Frequency	575.0 V @ 60 HZ
Agency Approvals	UR CSA CSA EEV
Ambient Temperature	40 °C
Auxiliary Box	NO AUXILLARY BOX
Auxiliary Box Lead Termination	None
Base Indicator	Rigid
Bearing Grease Type	Polyrex EM (-20F +300F)
Blower	None
Current @ Voltage	13.500 A @ 575.0 V
Design Code	A
Drip Cover	No Drip Cover
Duty Rating	CONT
Efficiency @ 100% Load	91.0 %
Electrically Isolated Bearing	Not Electrically Isolated
Feedback Device	NO FEEDBACK
Front Face Code	Standard
Front Shaft Indicator	None
Heater Indicator	No Heater
High Voltage Full Load Amps	13.5 a
Insulation Class	F

Part Detail

Revision	F
Type	AC
Mech. spec.	07H300
Base	
Status	PRD/A
Elec. spec.	07WGR871
Layout	07LYH300
Eff. date	05-02-2024
CD Diagram	CD0006
Poles	02
Leads	3#14
Proprietary	False
Created date	08-13-2015

Inverter Code	Inverter Ready
KVA Code	H
Lifting Lugs	Standard Lifting Lugs
Locked Bearing Indicator	Locked Bearing
Motor Lead Exit	Ko Box
Motor Lead Quantity/Wire Size	3 @ 14 AWG
Motor Lead Termination	Flying Leads
Motor Standards	NEMA
Motor Type	0750M
Mounting Arrangement	F1
Number of Poles	2
Overall Length	23.07 IN
Power Factor	91
Product Family	General Purpose
Pulley End Bearing Type	Ball
Pulley Face Code	C-Face
Pulley Shaft Indicator	Tapped & Key
Rodent Screen	None
Service Factor	1.15
Shaft Diameter	1.250 IN
Shaft Extension Location	Pulley End
Shaft Ground Indicator	No Shaft Grounding
Shaft Rotation	Reversible
Shaft Slinger Indicator	Shaft Slinger
Speed	3490 rpm
Speed Code	Single Speed
Starting Method	Direct on line
Thermal Device - Bearing	None
Thermal Device - Winding	None
Vibration Sensor Indicator	No Vibration Sensor
Winding Thermal 1	None
Winding Thermal 2	None

Nameplate

NP3441L									
CAT.NO.	EJMM2394T-5								
SPEC.	07H300R871G1								
HP	15								
VOLTS	575								
AMP	13.5								
RPM	3490								
FRAME	254JM		HZ	60			PH	3	
SER.F.	1.15	CODE	H	DES	A	CL	F		
NEMA-NOM-EFF	91	PF	91						
RATING	40C AMB-CONT								
CC	010A								
DE	6309		ODE	6307					
ENCL	TEFC	SN							
VPWM INVERTER READY									
CT6-60H(10:1)VT3-60H(20:1									

ABB Motors and Mechanical Inc.

WINDING # 07WGR871

Typical performance - not guaranteed values.

15 HP 3 PH 60 HZ 3490 RPM 575 V 0750M

TORQUES (LB-FT): PO=84 PU=28.4 LR=41.5 LRA=103

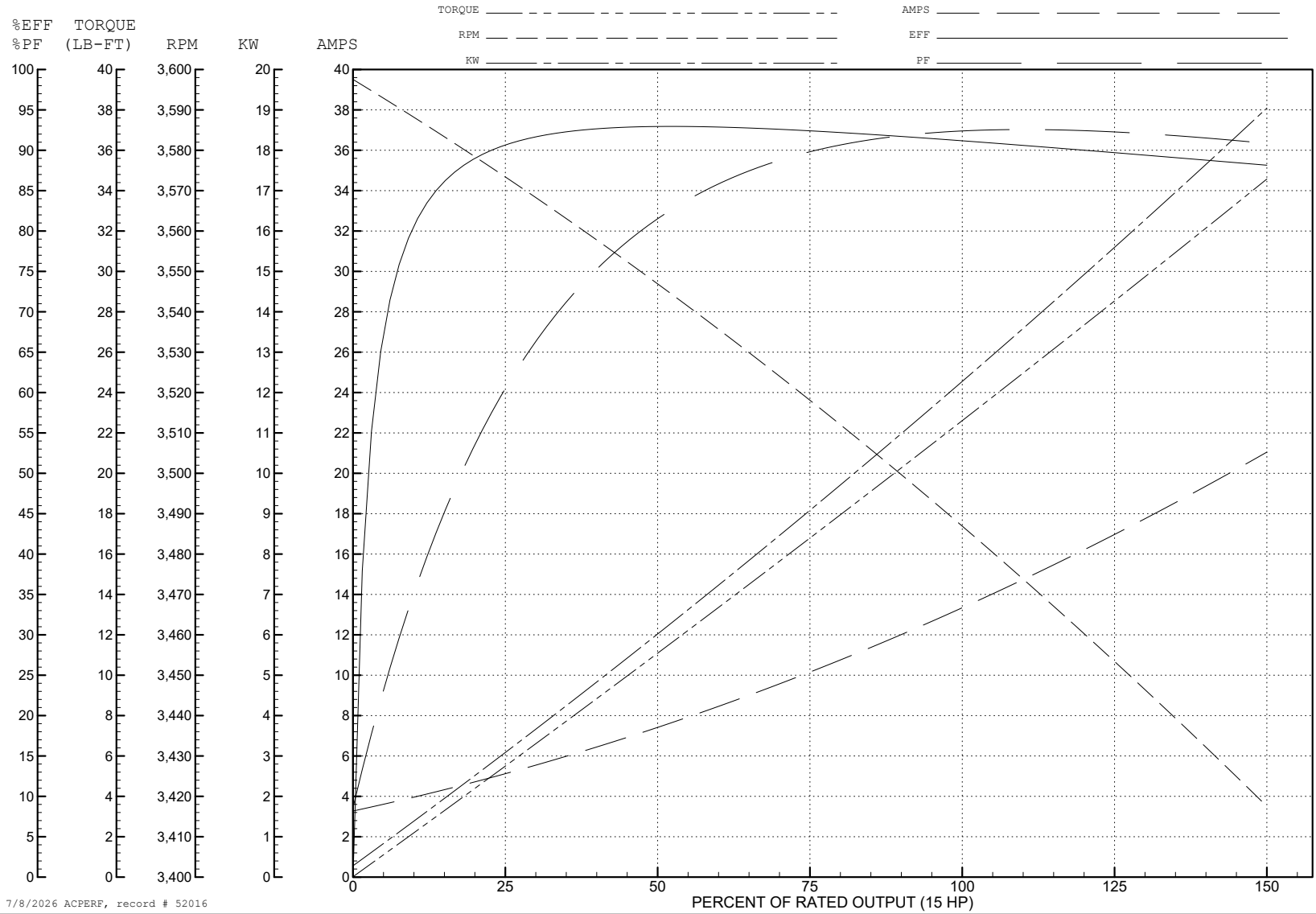

7/8/2026 ACPERF, record # 52016

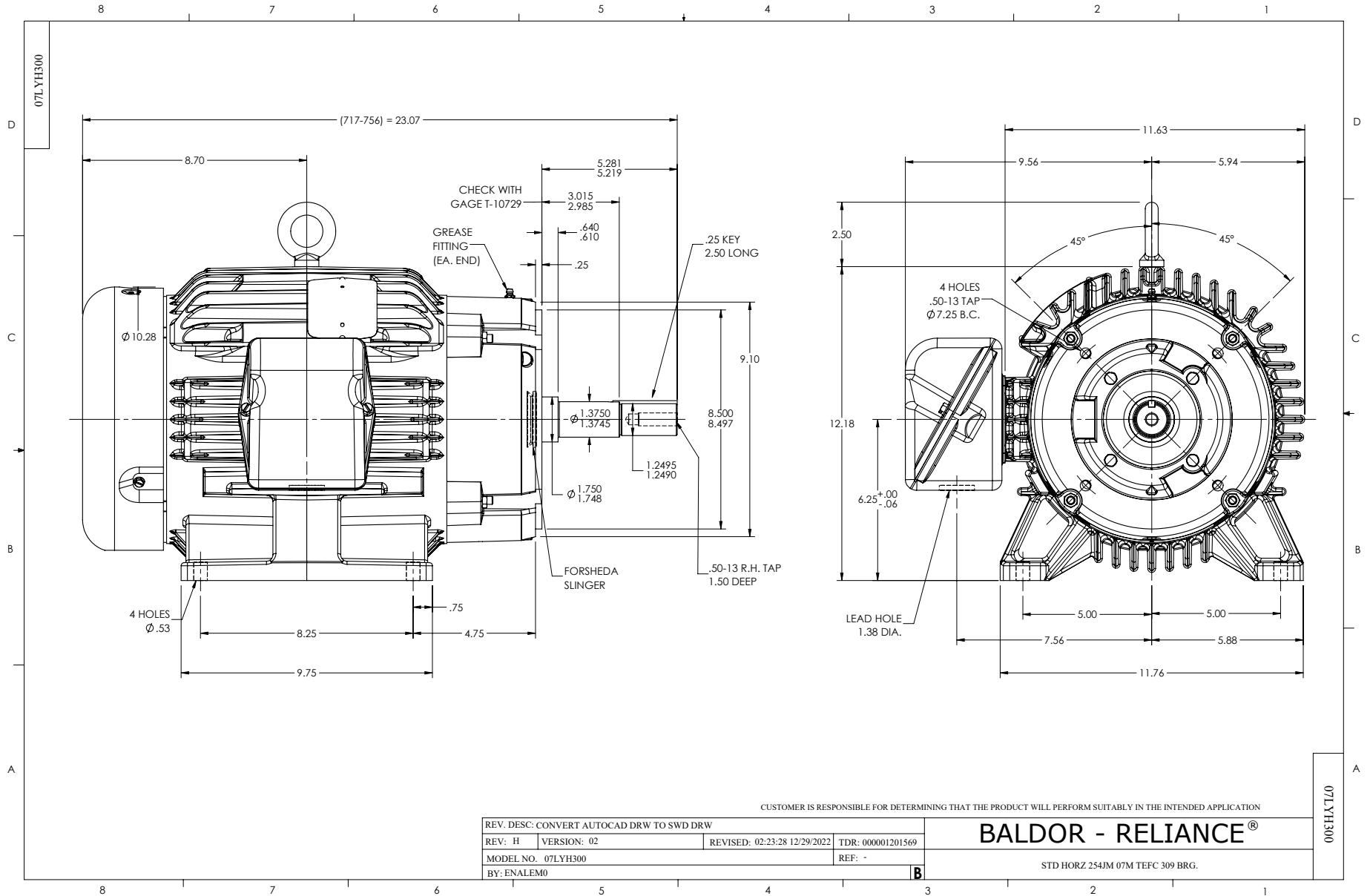

CD0006

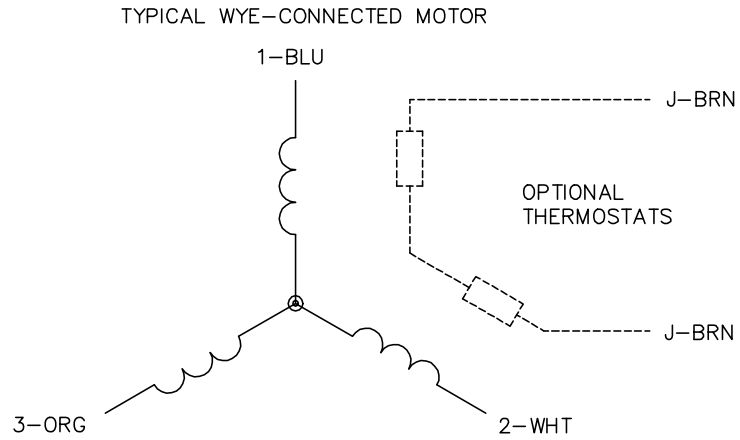

NOTES:

1. THREE LEAD MOTOR MAY BE EITHER WYE CONNECTED OR DELTA CONNECTED.
2. INTERCHANGE ANY TWO LINE LEADS TO REVERSE ROTATION.
3. OPTIONAL THERMOSTATS ARE PROVIDED WHEN SPECIFIED.
4. ACTUAL NUMBER OF INTERNAL PARALLEL CIRCUITS MAY VARY.
5. LEAD COLORS ARE OPTIONAL. LEADS MUST BE NUMBERED AS SHOWN.

CD0006

REV. DESC: ADD CLASS CONN00000007		
REV. LTR: E	VERSION: 01	TDR: 000001099922
FILE: \AAA\00005\141	REVISED: 10:24:49 02/19/2019	BY: ENBRIRO
MTL: -		© □

BALDOR - RELIANCE®

3PH, SV, 3 LEADS, WYE OR DELTA CONNECTED

SH 1 of 1