

ABB BALDOR RELIANCE III

Customer information packet

EHF2523T

15HP, 1765RPM, 3PH, 60HZ, 254T, 3948M, OPSB, F2

Class - None

Division - Not Applicable

Specifications

Enclosure	OPSB
Frame	254T
Frame Material	Steel
Frequency	60.00 Hz
Haz Area Class and Group	None
Haz Area Division	Not Applicable
Motor Letter Type	Three Phase
Output @ Frequency	15.000 HP @ 60 HZ
Phase	3
Synchronous Speed @ Frequency	1800 RPM @ 60 HZ
Voltage @ Frequency	230.0 V @ 60 HZ 460.0 V @ 60 HZ
Agency Approvals	CSA UR
Ambient Temperature	40 °C
Auxiliary Box	NO AUXILLARY BOX
Auxiliary Box Lead Termination	None
Base Indicator	Rigid
Bearing Grease Type	Polyrex EM (-20F +300F)
Blower	None
Current @ Voltage	38.000 A @ 208.0 V 36.000 A @ 230.0 V 18.000 A @ 460.0 V
Design Code	A
Drip Cover	No Drip Cover
Duty Rating	CONT
Efficiency @ 100% Load	93.0 %
Electrically Isolated Bearing	Not Electrically Isolated
Feedback Device	NO FEEDBACK
Front Face Code	Standard
Front Shaft Indicator	None
Heater Indicator	No Heater

Part Detail

Revision	T
Type	AC
Mech. spec.	39E172
Base	
Status	PRD/A
Elec. spec.	39WGY375
Layout	39LYE172
Eff. date	12-12-2025
CD Diagram	CD0180
Poles	04
Leads	9#12
Proprietary	False
Created date	10-02-2017

High Voltage Full Load Amps	18.0 a
Insulation Class	F
Inverter Code	Inverter Ready
KVA Code	G
Lifting Lugs	Standard Lifting Lugs
Locked Bearing Indicator	No Locked Bearing
Motor Lead Exit	Ko Box
Motor Lead Quantity/Wire Size	9 @ 10 AWG
Motor Lead Termination	Flying Leads
Motor Standards	NEMA
Motor Type	3948M
Mounting Arrangement	F2
Number of Poles	4
Overall Length	23.19 IN
Power Factor	85
Product Family	General Purpose
Pulley End Bearing Type	Ball
Pulley Face Code	Standard
Pulley Shaft Indicator	Standard
Rodent Screen	None
Service Factor	1.15
Shaft Diameter	1.625 IN
Shaft Extension Location	Pulley End
Shaft Ground Indicator	No Shaft Grounding
Shaft Rotation	Reversible
Shaft Slinger Indicator	No Slinger
Speed	1765 rpm
Speed Code	Single Speed
Starting Method	Direct on line
Thermal Device - Bearing	None
Thermal Device - Winding	None
Vibration Sensor Indicator	No Vibration Sensor
Winding Thermal 1	None
Winding Thermal 2	None

Nameplate

NP2094E06B03									
CAT.NO.	EHFM2523T								
SPEC.	39E172Y375G1								
HP	15								
VOLTS	230/460								
AMPS	36.4/18.2								
RPM	1770								
FRAME	254T	HZ	60	PH	3				
SER.F.	1.15	CODE	J	DES	A	CL	F		
NEMA-NOM-EFF	93	PF	83						
RATING	40C AMB-CONT								
CC	010A	USABLE AT 208V					N/A		
DE	6309	ODE	6208						
AUTO	MANUAL			NONE					
ENCL	OPSB	SN							
BLANK									

ABB Motors and Mechanical Inc.

WINDING # 39WGY375

Typical performance - not guaranteed values.

15 HP 3 PH 60 HZ 1770 RPM 460 V 3948M

TORQUES (LB-FT): PO=171 PU=79.1 LR=100 LRA=137

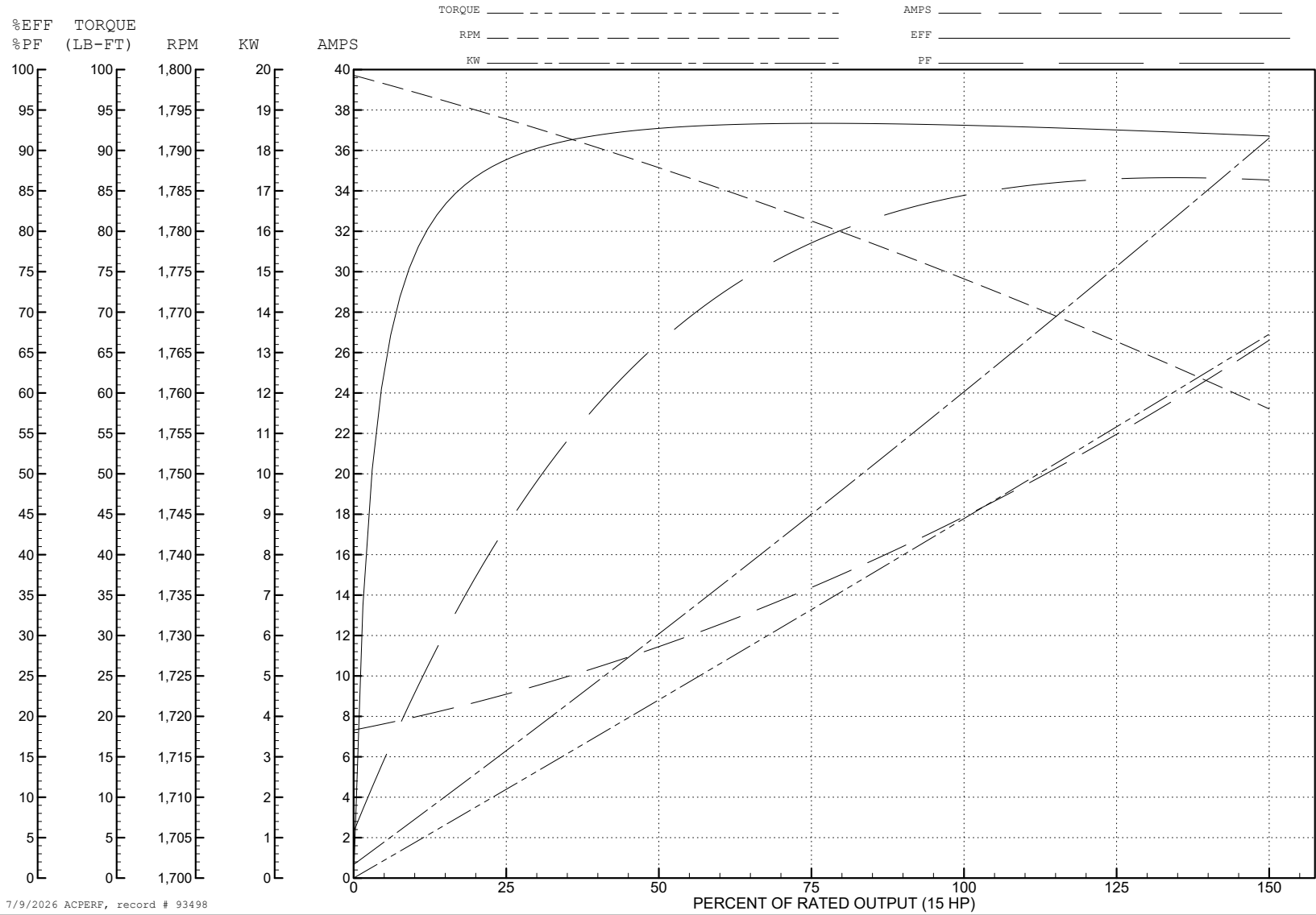

7/9/2026 ACPERF, record # 93498

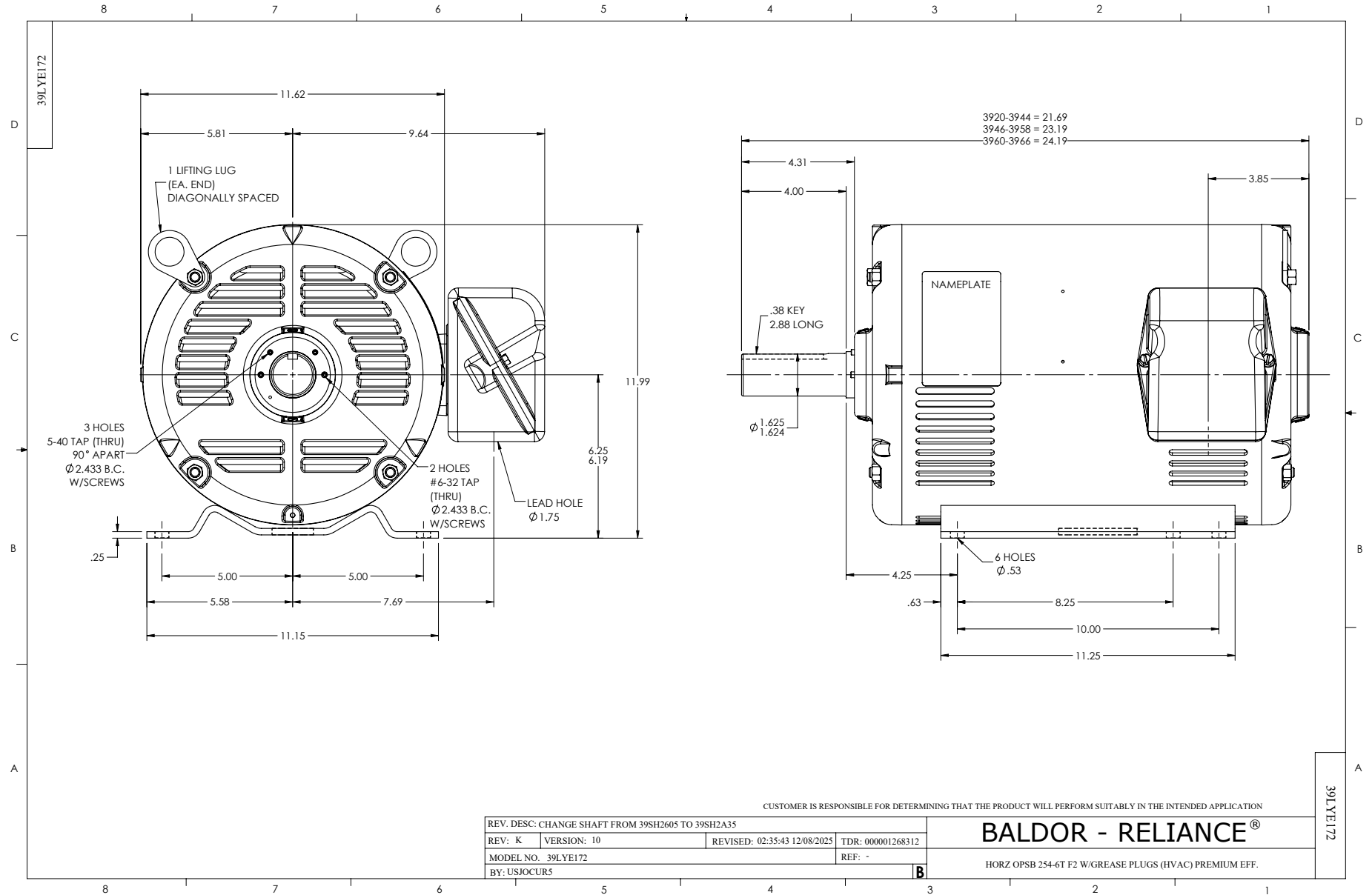

CD0180

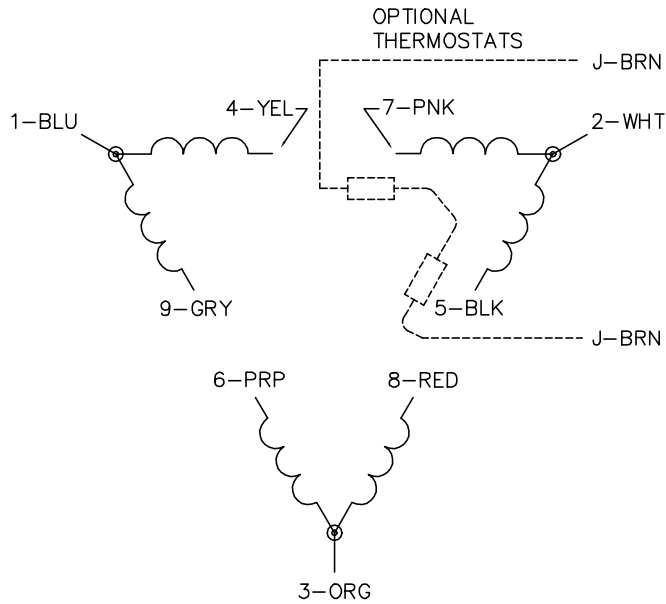

LOW VOLTAGE
(2D)

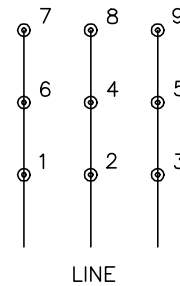

HIGH VOLTAGE
(1D)

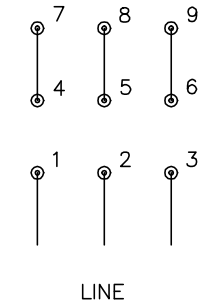

NOTES:

1. INTERCHANGE ANY TWO LINE LEADS TO REVERSE ROTATION.
2. OPTIONAL THERMOSTATS ARE PROVIDED WHEN SPECIFIED.
3. ACTUAL NUMBER OF INTERNAL PARALLEL CIRCUITS MAY BE A MULTIPLE OF THOSE SHOWN ABOVE.
4. LEAD COLORS ARE OPTIONAL. LEADS MUST ALWAYS BE NUMBERED AS SHOWN.

CD0180

REV. DESC: ADD CLASS CONN00000007		
REV. LTR: D	VERSION: 01	TDR: 000001099922
FILE: \AAA\00005\148	REVISED: 10: 25: 29 02/19/2019	BY: ENBRIRO
MTL: -	© □	

BALDOR - RELIANCE®

3PH, DV, 9 LEADS, DELTA CONNECTION

SH 1 of 1