



Customer information packet

ECTM4314T-G

60HP, 1780RPM, 3PH, 60HZ, 364T, A3658M, TEFC, F

Class - None

Division - Not Applicable

Specifications

Enclosure	TEFC
Frame	364T
Frame Material	Iron
Frequency	60.00 Hz
Haz Area Class and Group	None
Haz Area Division	Not Applicable
Motor Letter Type	Three Phase
Output @ Frequency	60.000 HP @ 60 HZ
Phase	3
Synchronous Speed @ Frequency	1800 RPM @ 60 HZ
Voltage @ Frequency	230.0 V @ 60 HZ 460.0 V @ 60 HZ
Agency Approvals	CCSAUSEEV
Ambient Temperature	40 °C
Auxiliary Box	NO AUXILLARY BOX
Base Indicator	Rigid
Bearing Grease Type	Polyrex EM (-20F +300F)
Current @ Voltage	140.000 A @ 230.0 V 70.000 A @ 460.0 V
Design Code	B
Drip Cover	No Drip Cover
Duty Rating	CONT
Efficiency @ 100% Load	95.0 %
Feedback Device	NO FEEDBACK
Heater Indicator	Heater Included, 115 V
High Voltage Full Load Amps	70.0 a
Insulation Class	F
Inverter Code	Inverter Ready
KVA Code	G
Lifting Lugs	Standard Lifting Lugs
Motor Lead Quantity/Wire Size	3 @ 4 AWG
Motor Standards	NEMA

Part detail

Revision	C
Type	AC
Mech. spec.	
Base	
Status	PRD/A
Elec. spec.	A36WG4075
Layout	617438-196
Eff. date	02-13-2025
CD Diagram	CD0180
Poles	04
Leads	3#4,6#6
Proprietary	False
Created date	04-13-2022

Motor Type	A3658M
Mounting Arrangement	F1
Number of Poles	4
Overall Length	33.78 IN
Power Factor	84
Product Family	Cooling Tower
Pulley End Bearing Type	Ball
Pulley Face Code	Standard
Service Factor	1.15
Shaft Diameter	2.374 IN
Shaft Ground Indicator	Shaft Grounding
Shaft Rotation	Reversible
Shaft Slinger Indicator	Shaft Slinger
Speed	1780 rpm
Speed Code	Single Speed
Starting Method	Direct on line
Thermal Device - Bearing	None
Thermal Device - Winding	None

Nameplate

000613007EW

CAT.NO.	ECTM4314T-G		SPEC NO.	A36-7881-4075					
HP	60HP	AMPS	140/70	VOLTS	230/460	DESIGN	B		
FRAME	364T	RPM	1780	HZ	60	AMB	40	SF	1.15
DRIVE END BEARING	65BC03JGG30A		PH	3	DUTY	CONT	INSUL.CLASS	F	
OPP D.E. BEARING	65BC03JGG30A		TYPE	P	ENCL	TEFC	CODE	G	
D.E.BRG.DATA	6313		POWER FACTOR	84		NEMA NOM EFFICIENCY	95		
O.D.E.BRG.DATA	6313		MAX CORR KVAR	15.00		GUARANTEED EFFICIENCY	94.1		
3/4 LOAD EFF.	95		NEMA NOM/CSA QUOTED EFF						
SER.NO.			MOTOR WEIGHT						

000901002AAA

INV DUTY 20:1 VT

AC induction motor performance data

Record #72794 - Typical performance - not guaranteed values

Winding	A36WG4075
Type	A3658M
Enclosure	TEFC

Nameplate data

Rated Output			60
Volts			230/460
Full Load Amps			140/70
R.P.M.			1780
Hz	60	Phase	3
KVA Code			G
S.F.			1.15
NEMA Nom. Eff.	95	Power Factor	84
Duty			CONT
S.F. Amps			

460 V, 60 Hz:

High Voltage Connection

Full Load Torque	176.4 LB-FT
Start Configuration	direct on line
Breakdown Torque	422 LB-FT
Pull-up Torque	276 LB-FT
Locked-rotor Torque	352 LB-FT
Starting Current	462 A
No-load Current	24.8
Line-line Res. @ 25°C	0.10816 Ω
Temp. Rise @ Rated Load	56°C
Temp. Rise @ S.F. Load	70°C
Locked-rotor Power Factor	32.3
Rotor inertia	0

Load Characteristics 460 V, 60 Hz, 60 HP

% of Rated Load	NL	25	50	75	100	125	150	SF
Power Factor	4	51	73	81	84	86	85	85
Efficiency	0	92.6	95.1	95.4	95.2	94.6	93.8	94.8
Speed	1798.9	1796.4	1792.4	1788	1783.7	1778.3	1772.3	1780
Line amperes	24.8	29.7	40.7	54.4	69.7	86.6	105	79.8

REVIEW

WINDING # A36WG4075

60 HP 3 PH 60 HZ 1780 RPM 460 V A3658M

TORQUES (LB-FT): P0=422.00 PU=276.00 LR=352.00 LRA=462.00

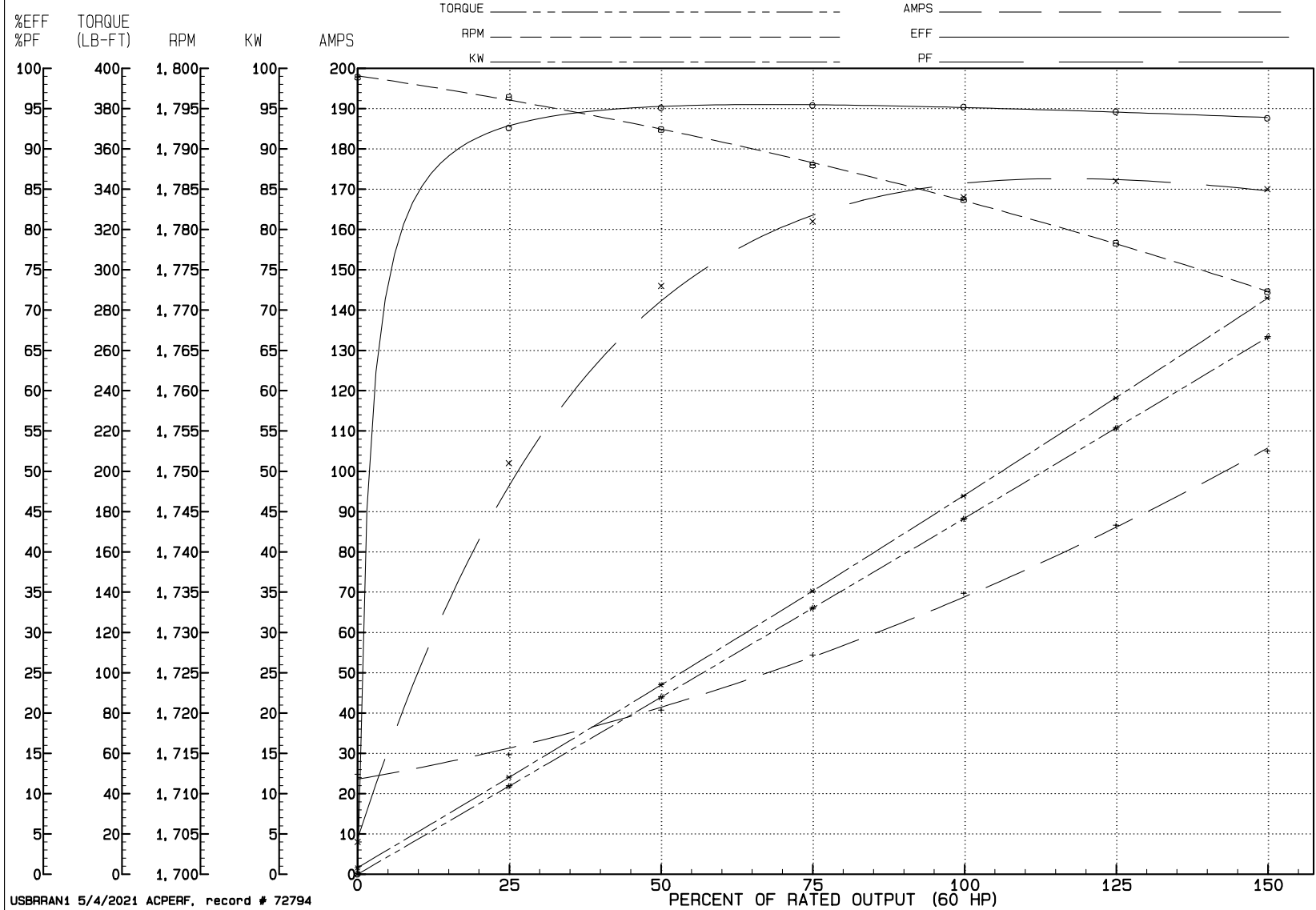

USBRRAN1 5/4/2021 ACPERF, record # 72794

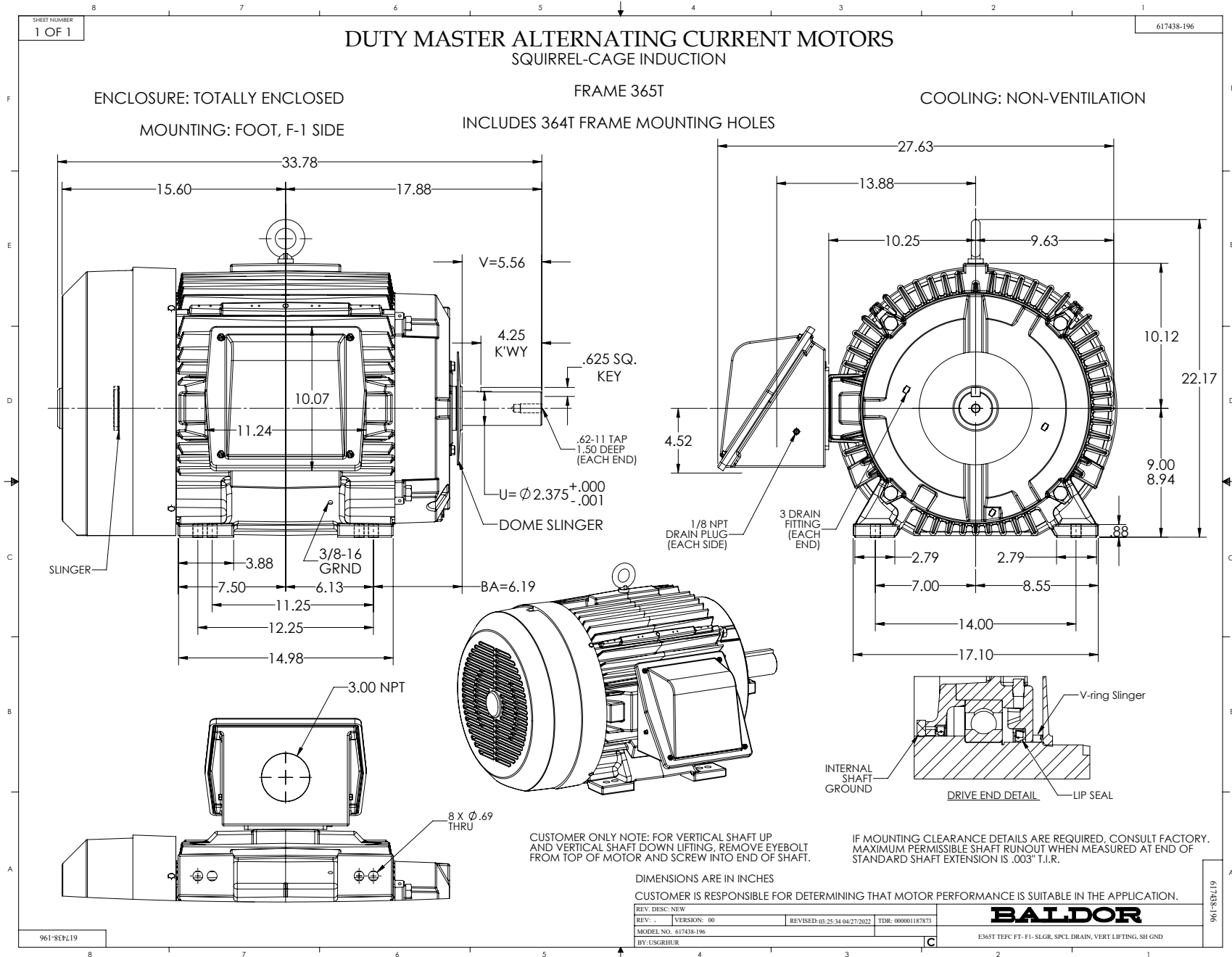

CD0180



LOW VOLTAGE
(2D)



HIGH VOLTAGE
(1D)



NOTES:

1. INTERCHANGE ANY TWO LINE LEADS TO REVERSE ROTATION.
2. OPTIONAL THERMOSTATS ARE PROVIDED WHEN SPECIFIED.
3. ACTUAL NUMBER OF INTERNAL PARALLEL CIRCUITS MAY BE A MULTIPLE OF THOSE SHOWN ABOVE.
4. LEAD COLORS ARE OPTIONAL. LEADS MUST ALWAYS BE NUMBERED AS SHOWN.

CD0180

REV. DESC: ADD CLASS CONN00000007		
REV. LTR: D	VERSION: 01	TDR: 000001099922
FILE: \AAA\00005\148	REVISED: 10: 25: 29 02/19/2019	BY: ENBRIRO
MTL: -	© □	

BALDOR - RELIANCE®

3PH, DV, 9 LEADS, DELTA CONNECTION

SH 1 of 1