

# ABB BALDOR RELIANCE III

---

## Customer information packet

### ECTM3664T-5G

2HP, 1165RPM, 3PH, 60HZ, 184T, 0642M, TEFC, F1

Class - None

Division - Not Applicable

**Specifications**

<b>Enclosure</b>	TEFC
<b>Frame</b>	184T
<b>Frame Material</b>	Iron
<b>Frequency</b>	60.00 Hz
<b>Haz Area Class and Group</b>	None
<b>Haz Area Division</b>	Not Applicable
<b>Motor Letter Type</b>	Three Phase
<b>Output @ Frequency</b>	2.000 HP @ 60 HZ
<b>Phase</b>	3
<b>Synchronous Speed @ Frequency</b>	1200 RPM @ 60 HZ
<b>Voltage @ Frequency</b>	575.0 V @ 60 HZ
<b>Agency Approvals</b>	CSA EEV NEMA PREMIUM NEMA_PREMIUM UR
<b>Ambient Temperature</b>	40 °C
<b>Auxiliary Box</b>	NO AUXILLARY BOX
<b>Auxiliary Box Lead Termination</b>	None
<b>Base Indicator</b>	Rigid
<b>Bearing Grease Type</b>	Polyrex EM (-20F +300F)
<b>Blower</b>	None
<b>Current @ Voltage</b>	2.500 A @ 575.0 V
<b>Design Code</b>	B
<b>Drip Cover</b>	No Drip Cover
<b>Duty Rating</b>	CONT
<b>Efficiency @ 100% Load</b>	88.5 %
<b>Electrically Isolated Bearing</b>	Not Electrically Isolated
<b>Feedback Device</b>	NO FEEDBACK
<b>Front Shaft Indicator</b>	None
<b>Heater Indicator</b>	Heater Included, 115 V
<b>High Voltage Full Load Amps</b>	2.5 a
<b>Insulation Class</b>	F

**Part Detail**

<b>Revision</b>	C
<b>Type</b>	AC
<b>Mech. spec.</b>	06J518
<b>Base</b>	
<b>Status</b>	PRD/A
<b>Elec. spec.</b>	06WGX236
<b>Layout</b>	06LYJ518
<b>Eff. date</b>	06-08-2023
<b>CD Diagram</b>	CD0006
<b>Poles</b>	06
<b>Leads</b>	3#16
<b>Proprietary</b>	False
<b>Created date</b>	04-20-2022

<b>Inverter Code</b>	Inverter Ready
<b>KVA Code</b>	K
<b>Lifting Lugs</b>	Standard Lifting Lugs
<b>Locked Bearing Indicator</b>	Locked Bearing
<b>Motor Lead Quantity/Wire Size</b>	3 @ 16 AWG
<b>Motor Lead Termination</b>	Flying Leads
<b>Motor Standards</b>	NEMA
<b>Motor Type</b>	0642M
<b>Mounting Arrangement</b>	F1
<b>Number of Poles</b>	6
<b>Overall Length</b>	15.93 IN
<b>Power Factor</b>	68
<b>Product Family</b>	Chemical Processing (Not DC)
<b>Pulley End Bearing Type</b>	Sealed Bearing
<b>Pulley Face Code</b>	Standard
<b>Pulley Shaft Indicator</b>	Tapped & Key
<b>Rodent Screen</b>	None
<b>RoHS Status</b>	ROHS COMPLIANT
<b>Service Factor</b>	1.15
<b>Shaft Diameter</b>	1.125 IN
<b>Shaft Ground Indicator</b>	Shaft Grounding
<b>Shaft Rotation</b>	Reversible
<b>Shaft Slinger Indicator</b>	Shaft Slinger
<b>Speed</b>	1165 rpm
<b>Speed Code</b>	Single Speed
<b>Starting Method</b>	Direct on line
<b>Thermal Device - Bearing</b>	None
<b>Thermal Device - Winding</b>	None
<b>Vibration Sensor Indicator</b>	No Vibration Sensor
<b>Winding Thermal 1</b>	None
<b>Winding Thermal 2</b>	None

**Nameplate**

<b>NP1260</b>									
<b>CAT.NO.</b>	ECTM3664T-5G								
<b>SPEC.</b>	06J518X236G1								
<b>HP</b>	2								
<b>VOLTS</b>	575								
<b>AMP</b>	2.5								
<b>RPM</b>	1165								
<b>FRAME</b>	184T	<b>HZ</b>	60	<b>PH</b>	3				
<b>SER.F.</b>	1.15	<b>CODE</b>	K	<b>DES</b>	B	<b>CL</b>	F		
<b>NEMA-NOM-EFF</b>	88.5	<b>PF</b>	68						
<b>RATING</b>	40C AMB-CONT								
<b>CC</b>									
<b>DE</b>	6206	<b>ODE</b>	6205						
<b>ENCL</b>	TEFC	<b>SN</b>							
INV DUTY 20:1 VT									

ABB Motors and Mechanical Inc.

WINDING # 06WGX236

Typical performance - not guaranteed values.

2 HP 3 PH 60 HZ 1165 RPM 575 V 0642M

TORQUES (LB-FT): PO=31.3 PU=16.7 LR=19.9 LRA=16.7

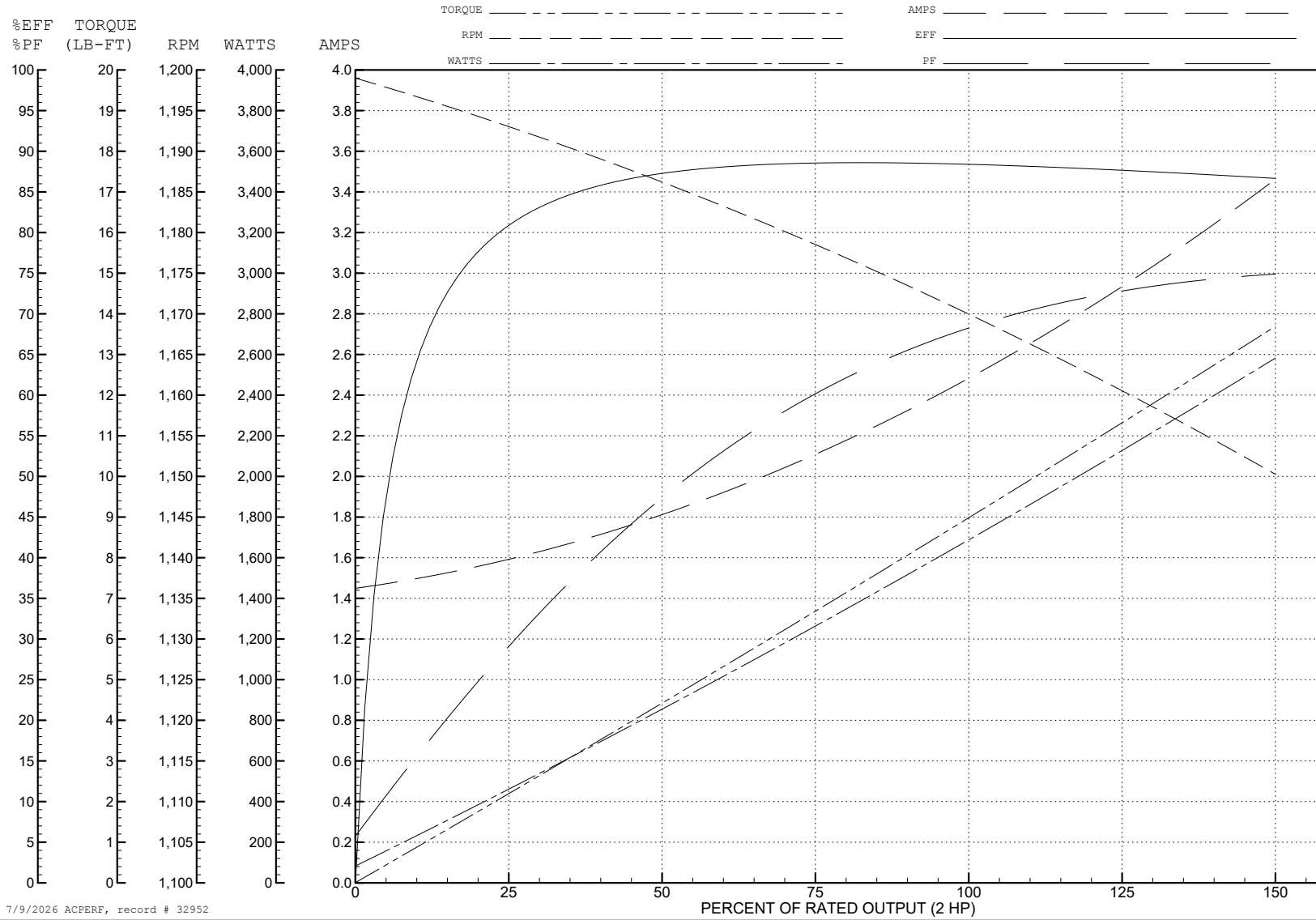

7/9/2026 ACPERF, record # 32952

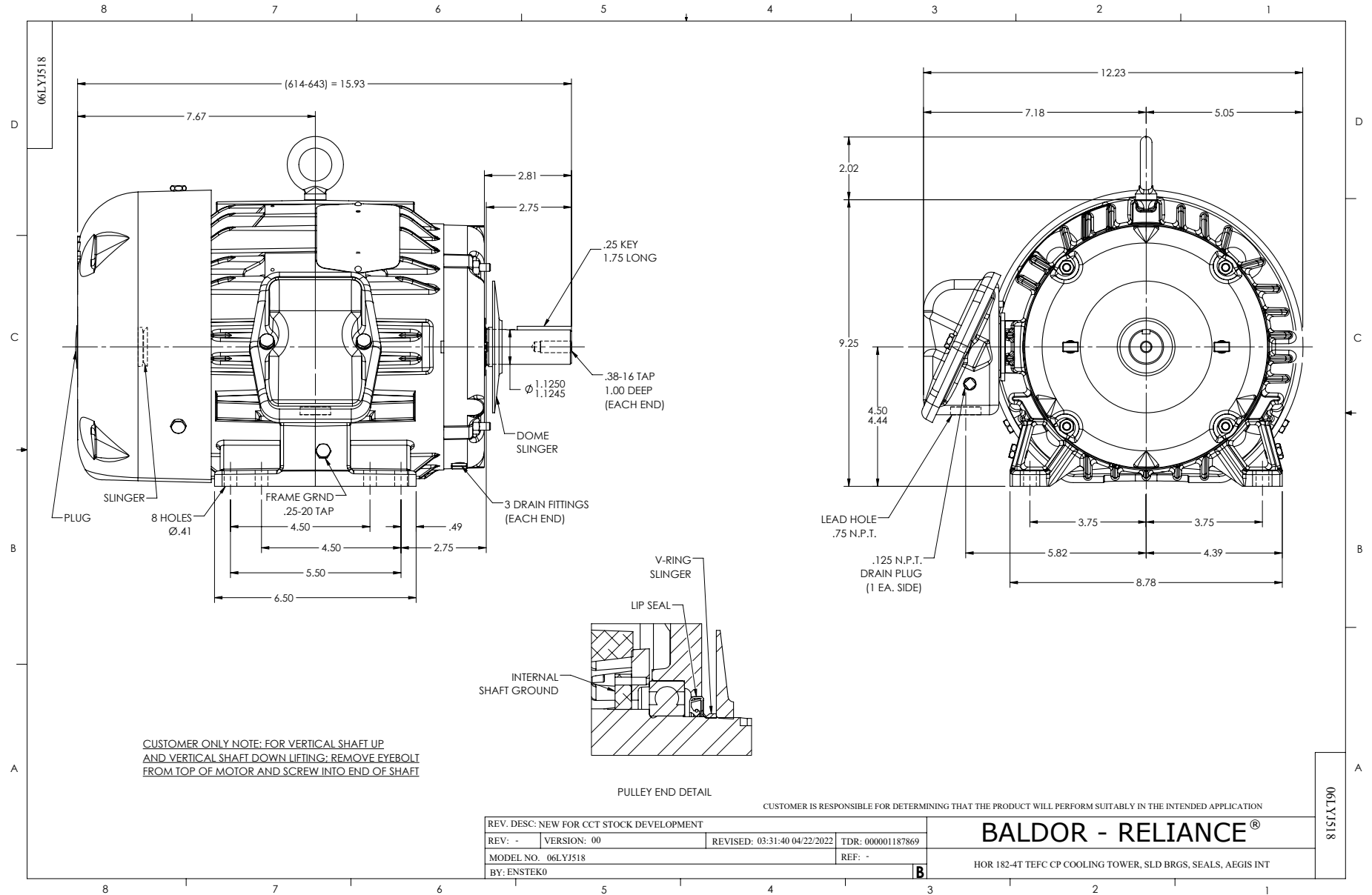

CD0006



NOTES:

1. THREE LEAD MOTOR MAY BE EITHER WYE CONNECTED OR DELTA CONNECTED.
2. INTERCHANGE ANY TWO LINE LEADS TO REVERSE ROTATION.
3. OPTIONAL THERMOSTATS ARE PROVIDED WHEN SPECIFIED.
4. ACTUAL NUMBER OF INTERNAL PARALLEL CIRCUITS MAY VARY.
5. LEAD COLORS ARE OPTIONAL. LEADS MUST BE NUMBERED AS SHOWN.

CD0006

REV. DESC: ADD CLASS CONN00000007		
REV. LTR: E	VERSION: 01	TDR: 000001099922
FILE: \AAA\00005\141	REVISED: 10:24:49 02/19/2019	BY: ENBRIRO
MTL: -	© □	

**BALDOR - RELIANCE®**

3PH, SV, 3 LEADS, WYE OR DELTA CONNECTED

SH 1 of 1