

# ABB BALDOR RELIANCE III

---

## Customer information packet

ECS101T4H7FF4

7.5HP, 1800RPM, 3PH, 60HZ, 213T, TEFC, TOP

Class - None

Division - Not Applicable

**Specifications**

<b>Enclosure</b>	TEFC
<b>Frame</b>	213T
<b>Frame Material</b>	Steel
<b>Frequency</b>	60.00 Hz
<b>Haz Area Class and Group</b>	None
<b>Haz Area Division</b>	Not Applicable
<b>Motor Letter Type</b>	Three Phase
<b>Output @ Frequency</b>	7.500 HP @ 60 HZ
<b>Phase</b>	3
<b>Synchronous Speed @ Frequency</b>	1800 RPM @ 60 HZ
<b>Voltage @ Frequency</b>	460.0 V @ 60 HZ
<b>Agency Approvals</b>	UL WEEE
<b>Ambient Temperature</b>	40 °C
<b>Auxiliary Box</b>	NO AUXILLARY BOX
<b>Auxiliary Box Lead Termination</b>	None
<b>Base Indicator</b>	Rigid
<b>Bearing Grease Type</b>	Polyrex EM (-20F +300F)
<b>Blower</b>	None
<b>Constant Torque Speed Range</b>	6
<b>Current @ Voltage</b>	8.700 A @ 460.0 V
<b>Drip Cover</b>	No Drip Cover
<b>Duty Rating</b>	CONT
<b>Efficiency @ 100% Load</b>	94.0 %
<b>Electrically Isolated Bearing</b>	Not Electrically Isolated
<b>Feedback Device</b>	NO FEEDBACK
<b>Heater Indicator</b>	No Heater
<b>High Voltage Full Load Amps</b>	8.7 a
<b>Insulation Class</b>	F
<b>Inverter Code</b>	Inverter Duty
<b>IP Rating</b>	NONE
<b>Lifting Lugs</b>	Standard Lifting Lugs

**Part Detail**

<b>Revision</b>	J
<b>Type</b>	AC
<b>Mech. spec.</b>	
<b>Base</b>	
<b>Status</b>	PRD/A
<b>Elec. spec.</b>	37WGA0016
<b>Layout</b>	37LYQ460
<b>Eff. date</b>	06-16-2025
<b>CD Diagram</b>	CD0006B03
<b>Poles</b>	04
<b>Leads</b>	3#12 19" LONG LEADS
<b>Proprietary</b>	False
<b>Created date</b>	07-16-2020

<b>Locked Bearing Indicator</b>	No Locked Bearing
<b>Motor Lead Termination</b>	Flying Leads
<b>Motor Standards</b>	NEMA
<b>Motor Type</b>	3730B
<b>Mounting Arrangement</b>	F1
<b>Number of Poles</b>	4
<b>Overall Length</b>	18.10 IN
<b>Power Factor</b>	92
<b>Product Family</b>	General Purpose
<b>Pulley Face Code</b>	Standard
<b>Rodent Screen</b>	None
<b>Service Factor</b>	1.00
<b>Shaft Diameter</b>	1.375 IN
<b>Shaft Ground Indicator</b>	Shaft Grounding
<b>Shaft Rotation</b>	Reversible
<b>Speed</b>	1800 rpm
<b>Speed Code</b>	Single Speed
<b>Starting Method</b>	Direct on line
<b>Thermal Device - Bearing</b>	None
<b>Thermal Device - Winding</b>	None
<b>Vibration Sensor Indicator</b>	No Vibration Sensor
<b>Winding Thermal 1</b>	None
<b>Winding Thermal 2</b>	None

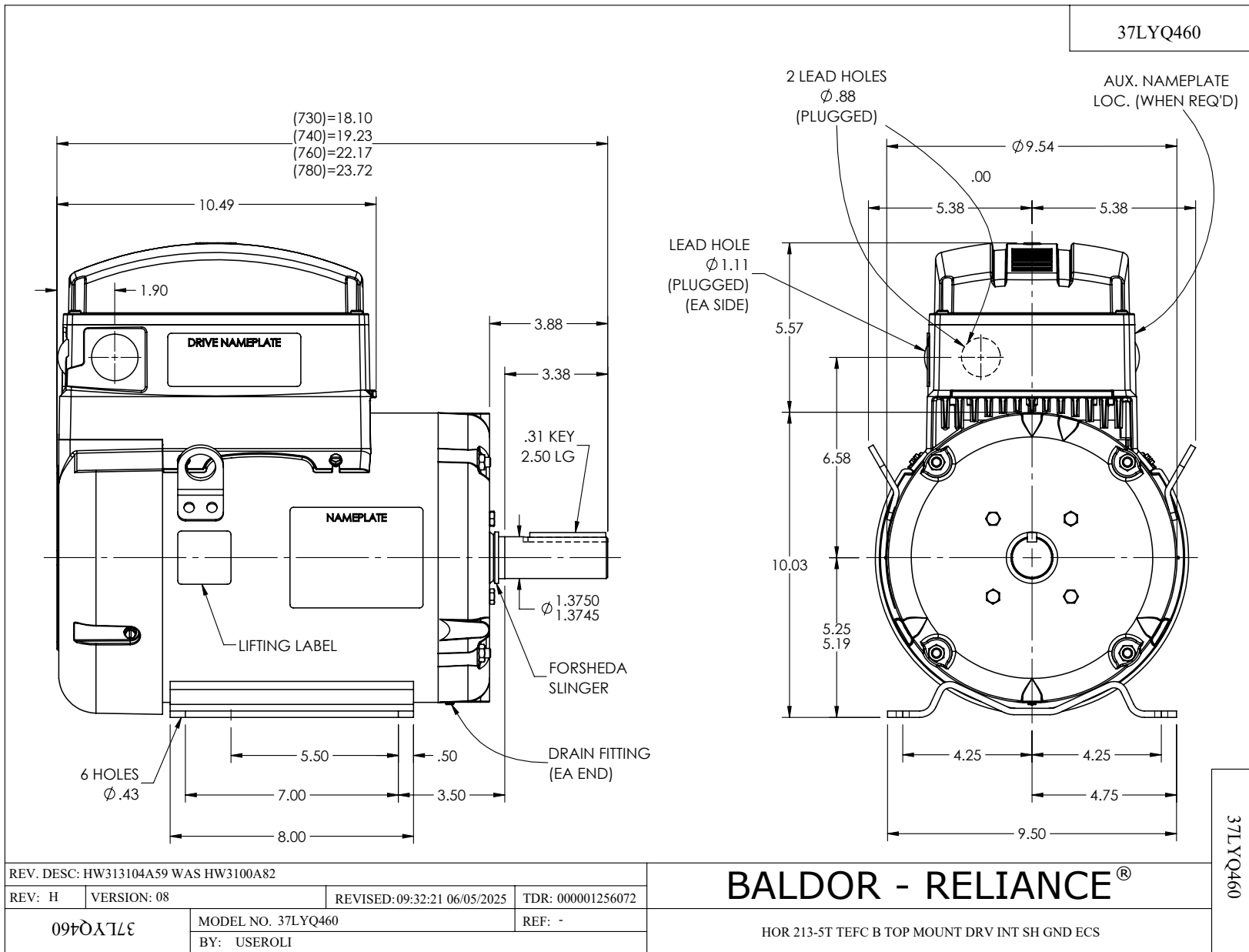

36CB3503A00

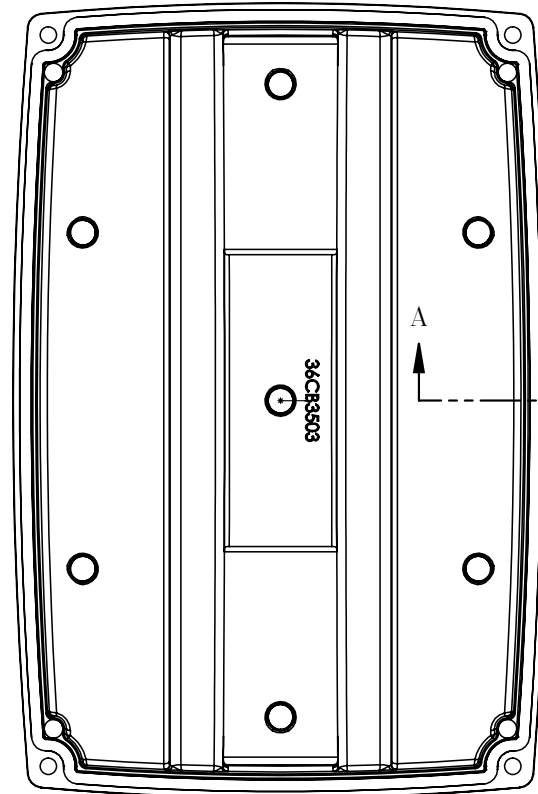

MATERIAL: RAMPF, RAKU-PUR 32-3280-51L

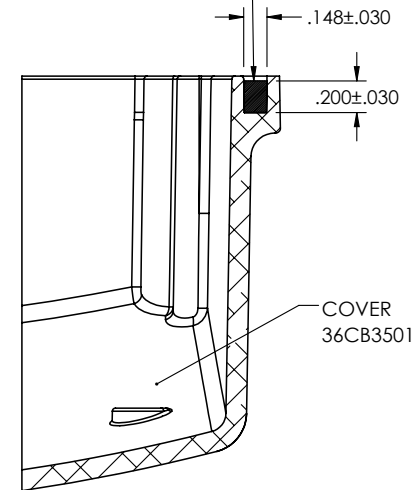

SECTION A-A

36CB3503A00

REV. DESC: NEW

REV: -	VERSION: 00	REVISED: 09:13:16 01/15/2020	TDR: 000001129989
--------	-------------	------------------------------	-------------------



MODEL NO. 36CB3503A00	REF: -
BY: ENMARS0	Material: -

**BALDOR - RELIANCE®**

36 & 37 FRAME TOP ECM ALUMINUM COVER WITH FOAM SEAL

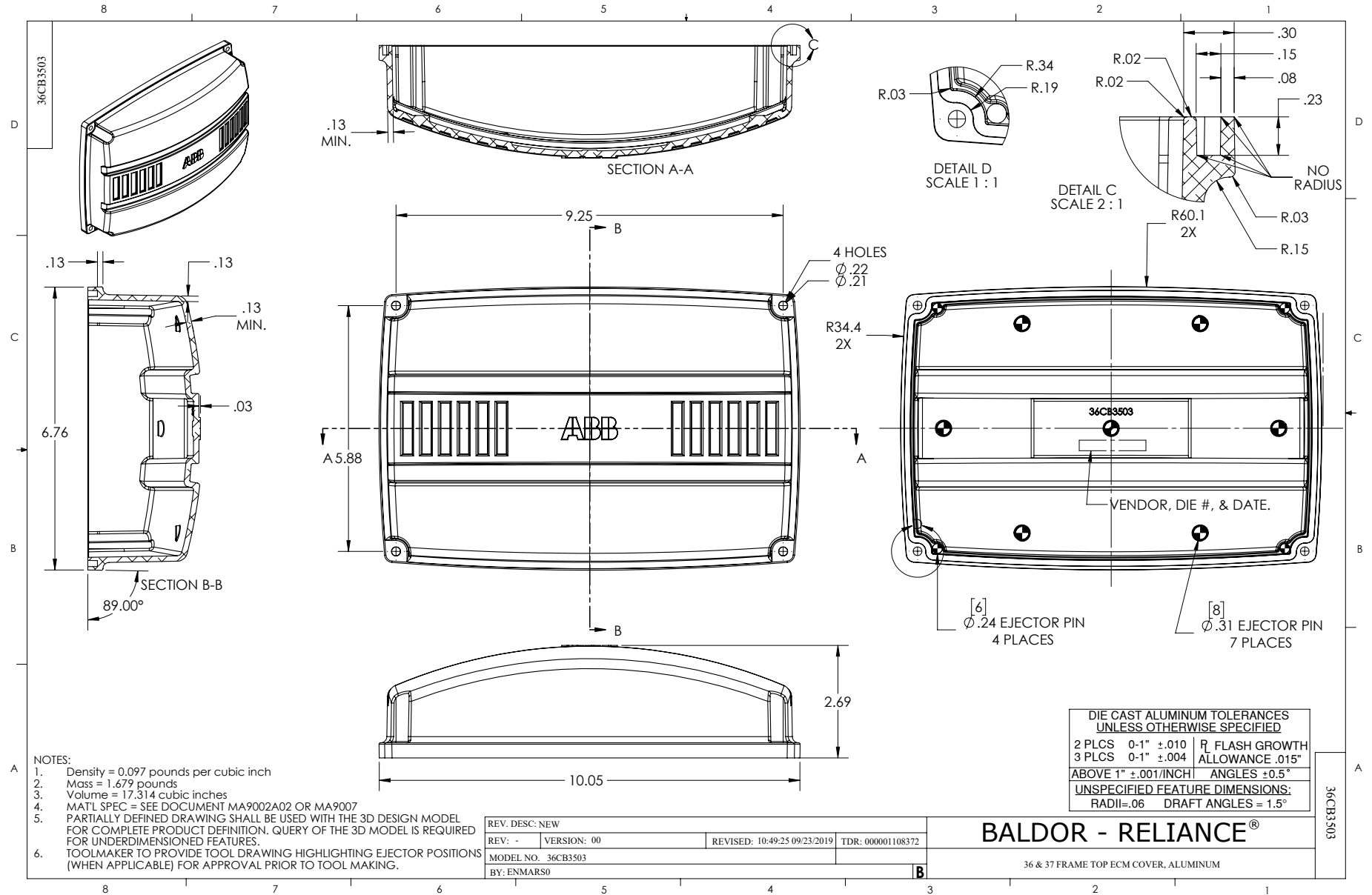

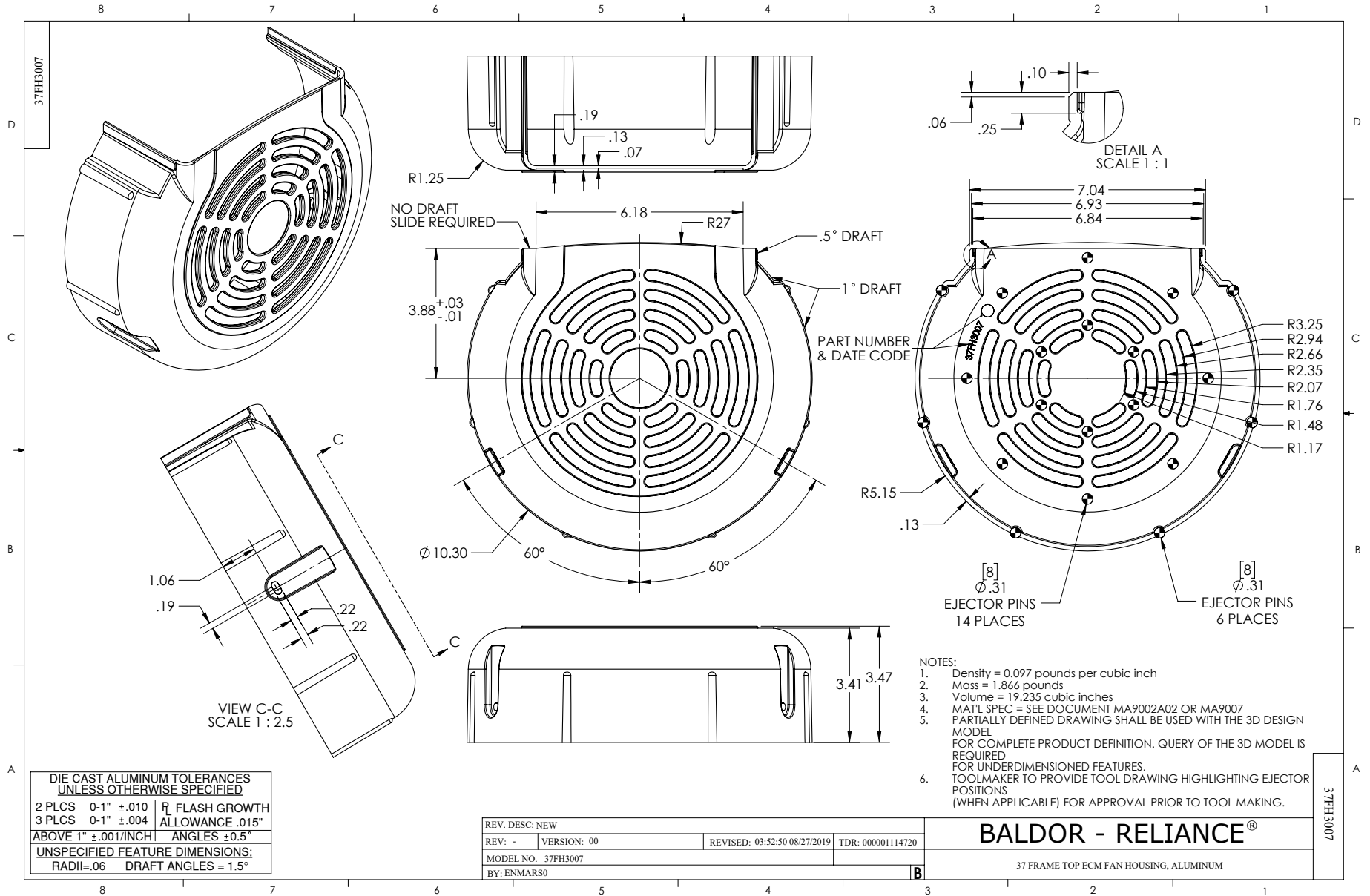

CD0006



NOTES:

1. THREE LEAD MOTOR MAY BE EITHER WYE CONNECTED OR DELTA CONNECTED.
2. INTERCHANGE ANY TWO LINE LEADS TO REVERSE ROTATION.
3. OPTIONAL THERMOSTATS ARE PROVIDED WHEN SPECIFIED.
4. ACTUAL NUMBER OF INTERNAL PARALLEL CIRCUITS MAY VARY.
5. LEAD COLORS ARE OPTIONAL. LEADS MUST BE NUMBERED AS SHOWN.

CD0006

REV. DESC: ADD CLASS CONN00000007		
REV. LTR: E	VERSION: 01	TDR: 000001099922
FILE: \AAA\00005\141	REVISED: 10: 24: 49 02/19/2019	BY: ENBRIRO
MTL: -	© □	

**BALDOR - RELIANCE®**

3PH, SV, 3 LEADS, WYE OR DELTA CONNECTED

SH 1 of 1

CD0006B03



NOTES:

1. INTERCHANGE ANY TWO LINE LEADS TO REVERSE ROTATION.
2. ACTUAL NUMBER OF INTERNAL PARALLEL CIRCUITS MAY VARY.

REV. DESC: CHANGE LEAD COLORS TO BLUE WHITE ORANGE		
REV. LTR: A	VERSION: 01	TDR: 000001158598
FILE: \AAA\00252\917	REVISED: 11:01:03 01/19/2021	BY: ENMARSO
MTL: -		© □

**BALDOR - RELIANCE®**

3PH, SV, 3 LEADS, WYE CONNECTED, ECS

SH 1 of 1

CD0006B03