

ABB BALDOR RELIANCE III

Customer information packet

ECS101T3K5P5FF4

5.5KW, 1500RPM, 3PH, 50HZ, D132S, 3730B, TEFC

Class - None

Division - Not Applicable

Specifications

Enclosure	TEFC
Frame	D132S
Frame Material	Steel
Frequency	50.00 Hz
Haz Area Class and Group	None
Haz Area Division	Not Applicable
Motor Letter Type	Brushless Wound Field PM Rotor
Output @ Frequency	5.500 KW @ 50 HZ
Phase	3
Synchronous Speed @ Frequency	1500 RPM @ 50 HZ
Voltage @ Frequency	380.0 V @ 50 HZ
Agency Approvals	WEEE UKCA CULUS CE
Ambient Temperature	40 °C
Auxiliary Box	NO AUXILLARY BOX
Auxiliary Box Lead Termination	None
Base Indicator	Rigid
Bearing Grease Type	Polyrex EM (-20F +300F)
Blower	None
Constant Torque Speed Range	5
Current @ Voltage	10.500 A @ 380.0 V
Design Code	B
Drip Cover	No Drip Cover
Duty Rating	S1
Efficiency @ 100% Load	92.9 %
Electrically Isolated Bearing	Not Electrically Isolated
Feedback Device	NO FEEDBACK
Frame Prefix	D
Heater Indicator	No Heater
High Voltage Full Load Amps	10.5 a

Part Detail

Revision	G
Type	AC
Mech. spec.	
Base	
Status	PRD/A
Elec. spec.	37WGA0020
Layout	37LYQ497
Eff. date	06-16-2025
CD Diagram	CD0006B03
Poles	04
Leads	3#12 19" LONG LEADS
Proprietary	False
Created date	01-11-2023

Insulation Class	F
Inverter Code	Inverter Duty
Lifting Lugs	Standard Lifting Lugs
Locked Bearing Indicator	Locked Bearing
Motor Lead Termination	Terminal Block
Motor Standards	IEC
Motor Type	3730B
Mounting Arrangement	B3
Number of Poles	4
Overall Length	17.87 IN
Power Factor	97
Product Family	General Purpose
Pulley Face Code	Standard
Rodent Screen	None
Service Factor	1.00
Shaft Diameter	1.497 IN
Shaft Ground Indicator	Shaft Grounding
Shaft Rotation	Reversible
Speed	1500 rpm
Speed Code	Single Speed
Starting Method	INVERTER SPECIAL
Thermal Device - Bearing	None
Thermal Device - Winding	None
Vibration Sensor Indicator	No Vibration Sensor
Winding Thermal 1	None
Winding Thermal 2	None

Volts	380	Max RPM	3000	Conn Diag.	CD0006B03	Leads	3
Amps	10.71	Max Amps		Cs Diagram	CS1126	BEMF	180.48
KW	5.5	VFD#	ECIN4A12P0			LD	28.09
RPM	1500	S.F.	1.00			LQ	80.586
Phase/Hz	3/50	Rating	40C AMB-S1			Rs	1.4059 Meas. L-L

60034-2-3 Motor Performance at Standardized Operating Points

	RPM	% Speed	LB-FT	% Torque	KW	Efficiency	Loss (% FL)	Watts Loss (W)
P1	1351	90%	25.8	100%	6.6	91.2	8.59%	478
P2	750	50%	25.8	100%	3.7	86.8	7.52%	418
P3	363	25%	25.8	100%	1.8	80.6	5.78%	321
P4	1351	90%	12.9	50%	3.3	91.0	4.42%	246
P5	751	50%	12.9	50%	1.8	89.5	2.91%	162
P6	751	50%	6.5	25%	0.9	88.0	1.70%	94
P7	360	25%	6.5	25%	0.4	83.0	1.22%	68

61800-9-2 PDS Performance at Reference Operating Points

	RPM	% Speed	LB-FT	% Torque	KW	System Efficiency	Loss (% FL)	Watts Loss (W)
P1	1501	100%	25.8	100%	7.4	91.1	9.70%	540
P2	750	50%	25.8	100%	3.7	84.7	8.94%	497
P3	255	17%	25.8	100%	1.3	71.4	6.72%	374
P4	1501	100%	12.9	50%	3.7	90.7	5.07%	282
P5	751	50%	12.9	50%	1.8	87.8	3.45%	192
P6	255	17%	12.9	50%	0.6	75.7	2.69%	150
P7	751	50%	6.5	25%	0.9	86.8	1.88%	105
P8	255	17%	6.4	25%	0.3	75.8	1.34%	75

Points not taken in certified order.

BALDOR • RELIANCE	DR By:	<u>R & D</u>	AC MOTOR PERFORMANCE CURVES	37WGA0020 37-0000-0494 Test - 112062
	CK By:	<u>USWEALE1</u>		
	APP By:			
	Date:	<u>03/14/2025</u>		

Volts	380	Max RPM	3000	Conn Diag.	CD0006B03	Leads	3
Amps	10.71	Max Amps		Cs Diagram	CS1126	BEMF	180.48
KW	5.5	VFD #	ECIN4A12P0			LD	28.09
RPM	1500	S.F.	1.00			LQ	80.586
Phase/Hz	3/50	Rating	40C AMB-S1			Rs	1.4059 Meas L-L

Constant Duty Operating Range

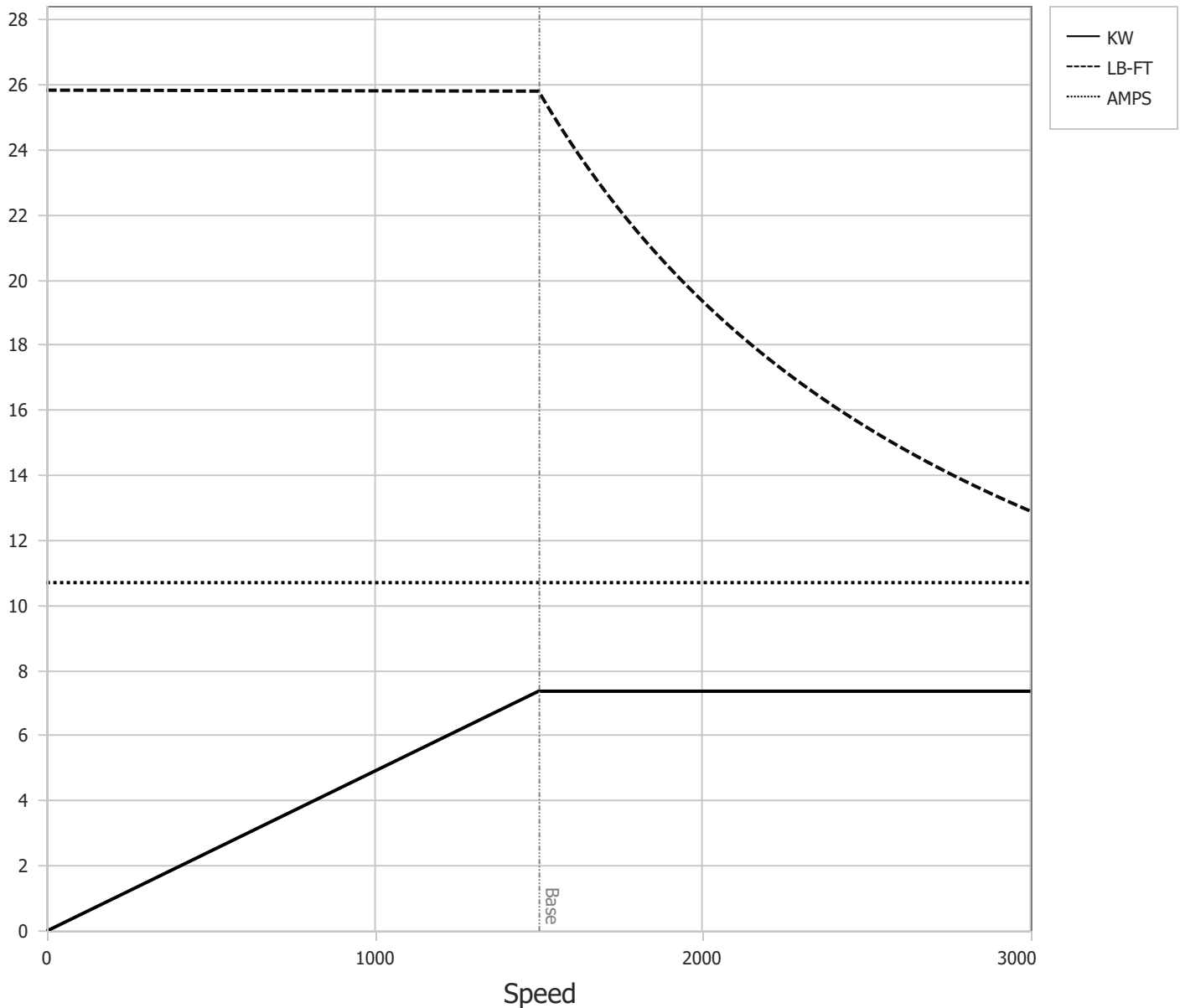

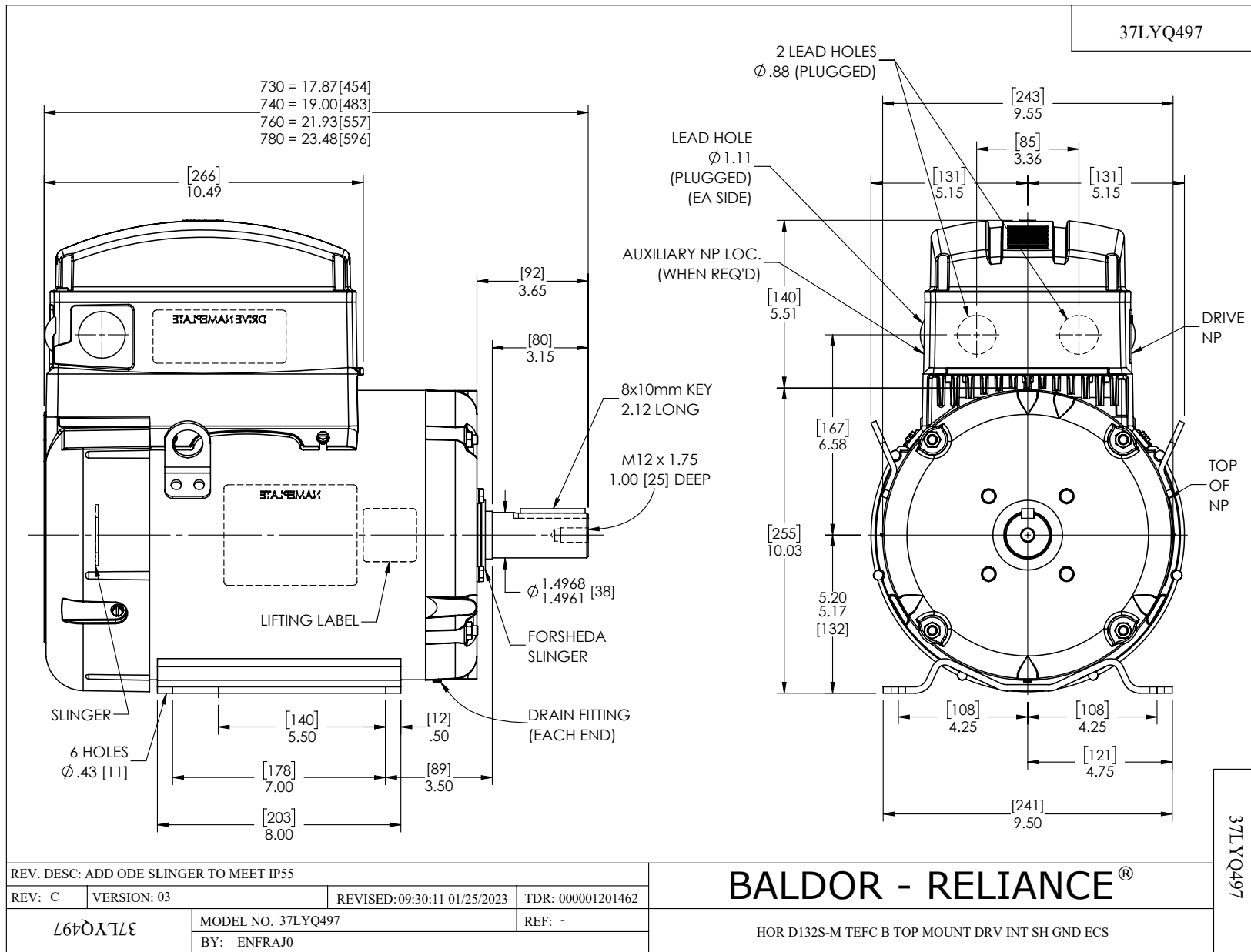

36CB3503A00

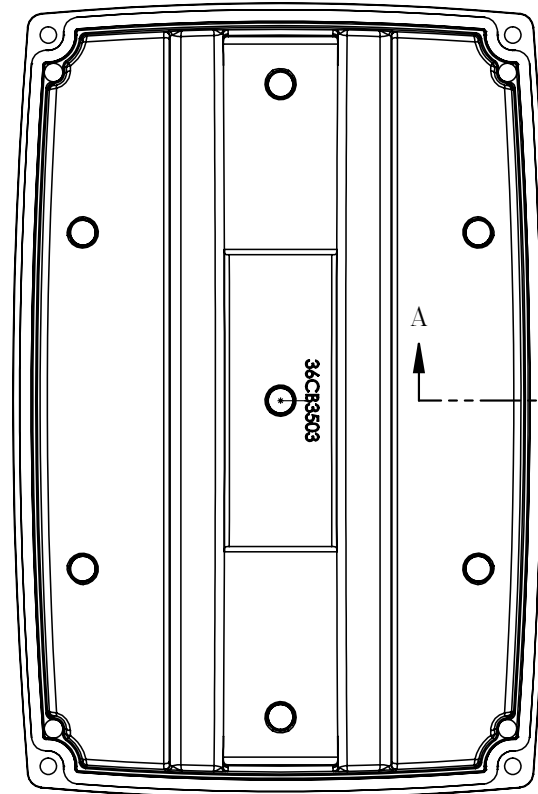

MATERIAL: RAMPF, RAKU-PUR 32-3280-51L

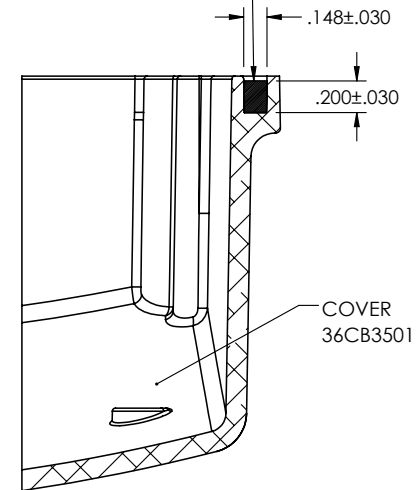

SECTION A-A

36CB3503A00

REV. DESC: NEW

REV: -	VERSION: 00	REVISED: 09:13:16 01/15/2020	TDR: 000001129989
--------	-------------	------------------------------	-------------------



MODEL NO. 36CB3503A00

REF: -

BY: ENMARS0

Material: -

BALDOR - RELIANCE®

36 & 37 FRAME TOP ECM ALUMINUM COVER WITH FOAM SEAL

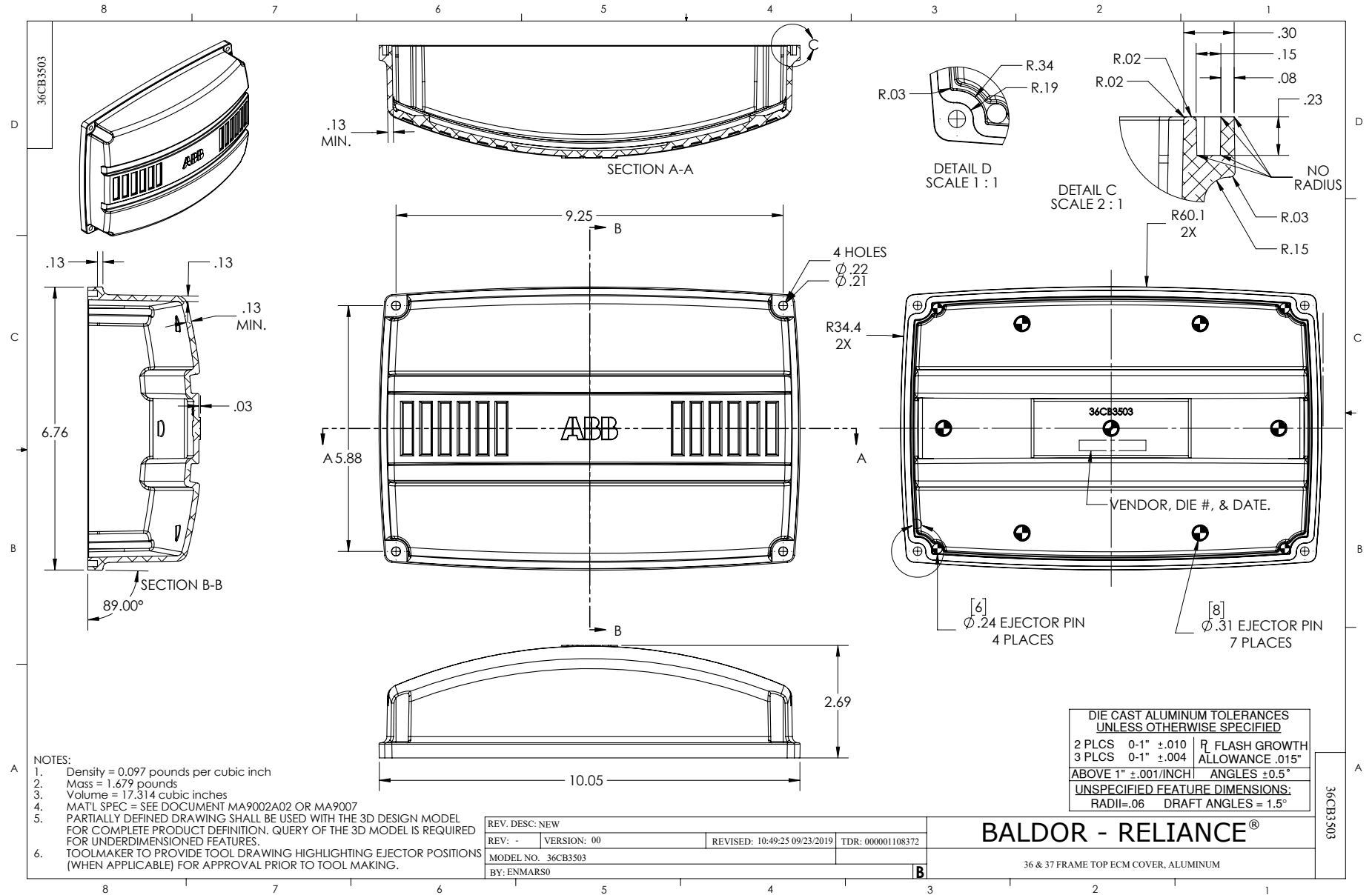

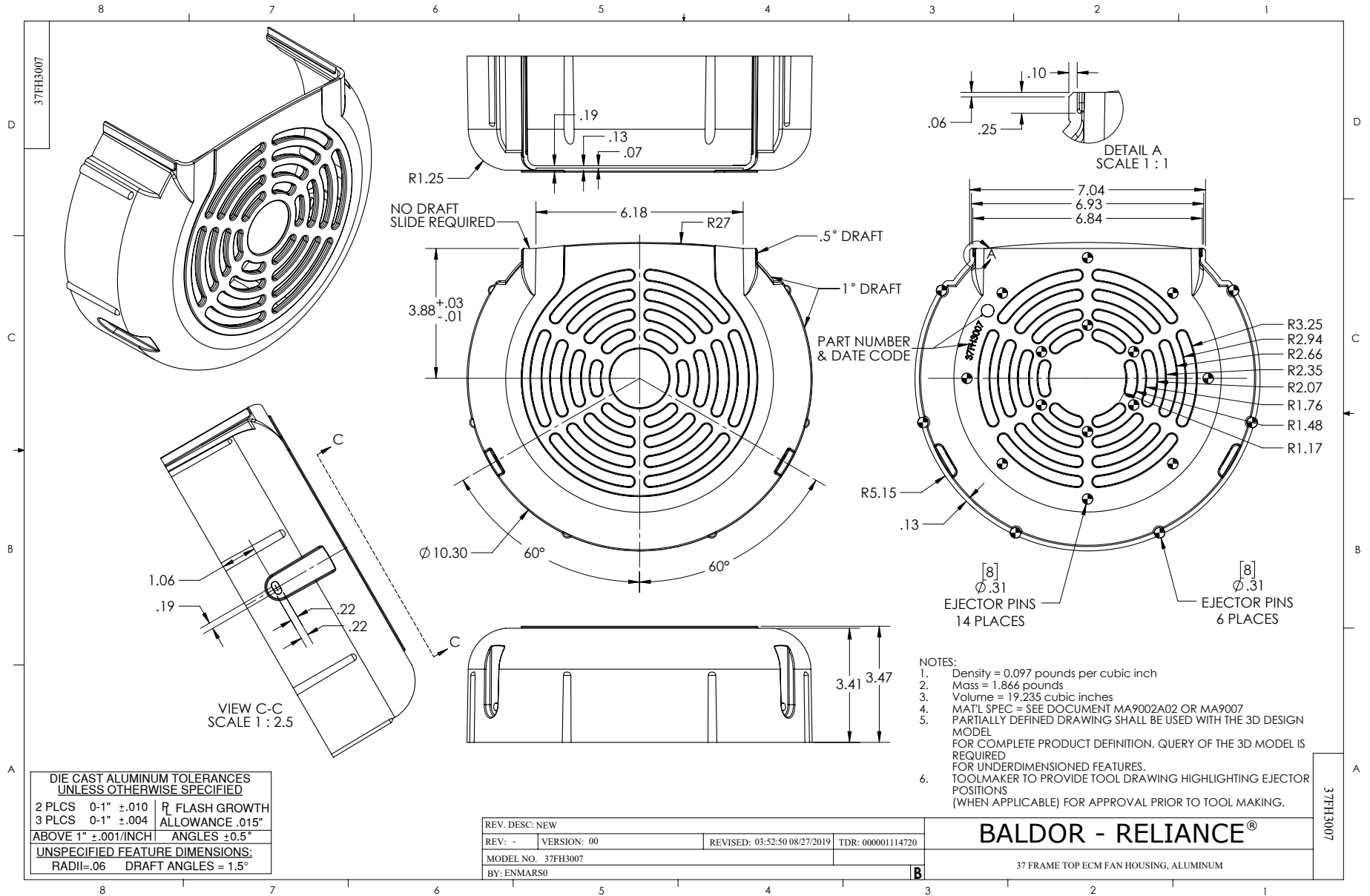

CD0005A25

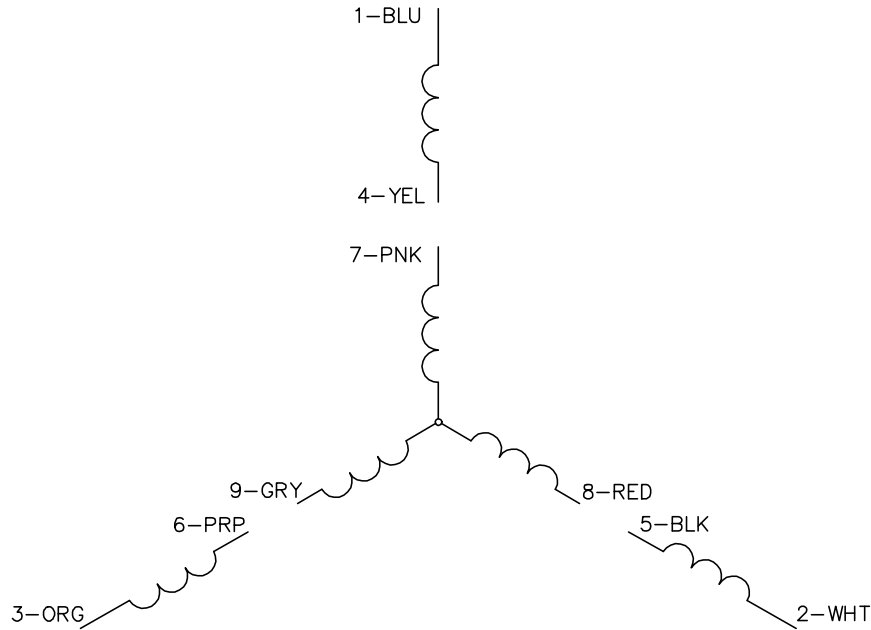

LOW VOLTAGE
(2Y)

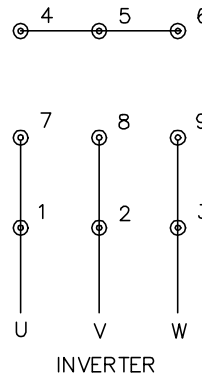

HIGH VOLTAGE
(1Y)

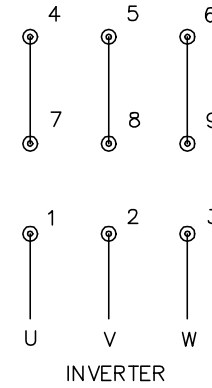

NOTES:

1. INTERCHANGE ANY TWO LINE LEADS TO REVERSE ROTATION.
2. ACTUAL NUMBER OF INTERNAL PARALLEL CIRCUITS MAY BE A MULTIPLE OF THOSE SHOWN ABOVE.
3. LEAD COLORS ARE OPTIONAL. LEADS MUST ALWAYS BE NUMBERED AS SHOWN.

REV. DESC: NEW		
REV. LTR: -	VERSION: 00	TDR: 000001135746
FILE: \AAA\00253\082	REVISED: 01:10:57 03/30/2020	BY: ENMARSO
MTL: -	© □	

BALDOR - RELIANCE®

3PH, DV, 9 LEADS, ECS
SH 1 of 1

CD0005A25

CD0006B03

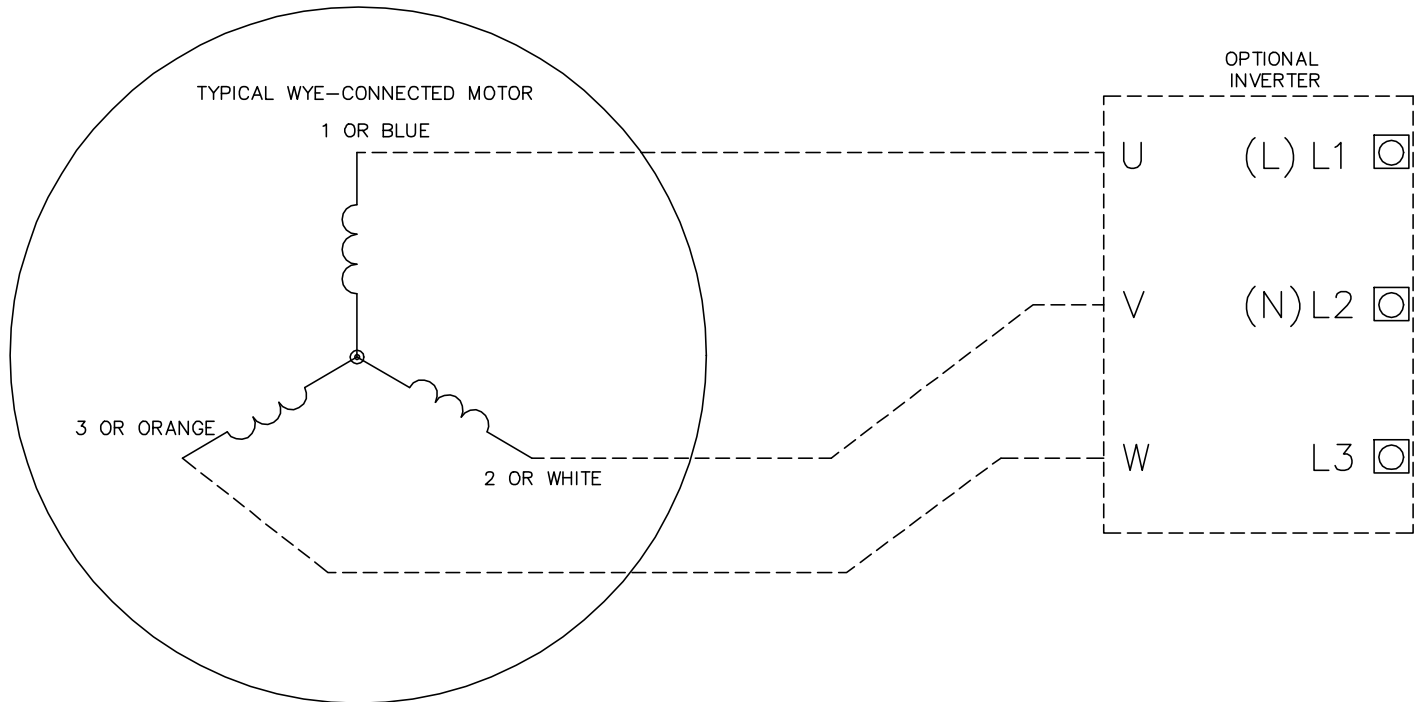

NOTES:

1. INTERCHANGE ANY TWO LINE LEADS TO REVERSE ROTATION.
2. ACTUAL NUMBER OF INTERNAL PARALLEL CIRCUITS MAY VARY.

CD0006B03

REV. DESC: CHANGE LEAD COLORS TO BLUE WHITE ORANGE		
REV. LTR: A	VERSION: 01	TDR: 000001158598
FILE: \AAA\00252\917	REVISED: 11:01:03 01/19/2021	BY: ENMARSO
MTL: -	© □	

BALDOR - RELIANCE®

3PH, SV, 3 LEADS, WYE CONNECTED, ECS

SH 1 of 1