



Customer information packet

ECS101M0H2DB4

2HP, 1800RPM, 3PH, 60HZ, 145TC, 3524B, TEFC, F1

Class - None

Division - Not Applicable

Specifications

Enclosure	TEFC
Frame	145TC
Frame Material	Steel
Frequency	60.00 Hz
Haz Area Class and Group	None
Haz Area Division	Not Applicable
Motor Letter Type	Brushless Wound Field PM Rotor
Output @ Frequency	2.000 HP @ 60 HZ
Phase	3
Synchronous Speed @ Frequency	1800 RPM @ 60 HZ
Voltage @ Frequency	230.0 V @ 60 HZ 460.0 V @ 60 HZ
Agency Approvals	WEEE CULUS
Ambient Temperature	40 °C
Auxillary Box	No Auxillary Box
Auxillary Box Lead Termination	None
Base Indicator	Rigid
Bearing Grease Type	Polyrex EM (-20F +300F)
Blower	None
Constant Torque Speed Range	6
Current @ Voltage	1.500 A @ 460.0 V 3.000 A @ 230.0 V
Design Code	B
Drip Cover	No Drip Cover
Duty Rating	CONT
Efficiency @ 100% Load	88.5 %
Electrically Isolated Bearing	Not Electrically Isolated
Feedback Device	NO FEEDBACK
Heater Indicator	No Heater
High Voltage Full Load Amps	1.5 a
Insulation Class	F

Part detail

Revision	A
Type	AC
Mech. spec.	35E5263
Base	
Status	PRD/A
Elec. spec.	35WGG983
Layout	35LYE5263
Eff. date	08-12-2024
CD Diagram	CD0005A25
Poles	04
Leads	9#16
Proprietary	False
Created date	03-15-2024

Inverter Code	Inverter Duty
KVA Code	N
Lifting Lugs	No Lifting Lugs
Locked Bearing Indicator	Locked Bearing
Motor Lead Quantity/Wire Size	9 @ 16 AWG
Motor Lead Termination	Flying Leads
Motor Standards	NEMA
Motor Type	3524B
Mounting Arrangement	F1
Number of Poles	4
Overall Length	13.29 IN
Power Factor	93
Product Family	General Purpose
Pulley Face Code	C-Face
Rodent Screen	None
RoHS Status	Y
Service Factor	1.00
Shaft Diameter	0.875 IN
Shaft Ground Indicator	Shaft Grounding
Shaft Rotation	Reversible
Speed	1800 rpm
Speed Code	Single Speed
Starting Method	Direct on line
Thermal Device - Bearing	None
Thermal Device - Winding	None
Vibration Sensor Indicator	No Vibration Sensor
Winding Thermal 1	None
Winding Thermal 2	None

Nameplate

NP3968A01A01									
CAT.NO.	ECS101M0H2DB4								
SPEC.	35E5263G983								
FRAME	145TC	ENCL.	TEFC	IP	54				
HP	2	40	C AMB	CONT					
NOM. EFF.	90.4	PF	93	SF	1.5				
VOLTS	230/460		FLA	4.8/2.4					
RPM	1800	RPM-MAX	4000						
HZ	60	PH.	3	CLASS	F				
BEMF (V)	148/296		RS (OHMS)	12.2					
LD (MH)	19.7/78.9		LQ (MH)	91.7/366					
VPWM	CHP	60	TO	120					
CT	6	TO	60	VT	1	TO	60		
MATCHED INV	AC5380-04XX-06A9-1/03A3-4								
DE	6205		ODE	6203					
SERIAL #									

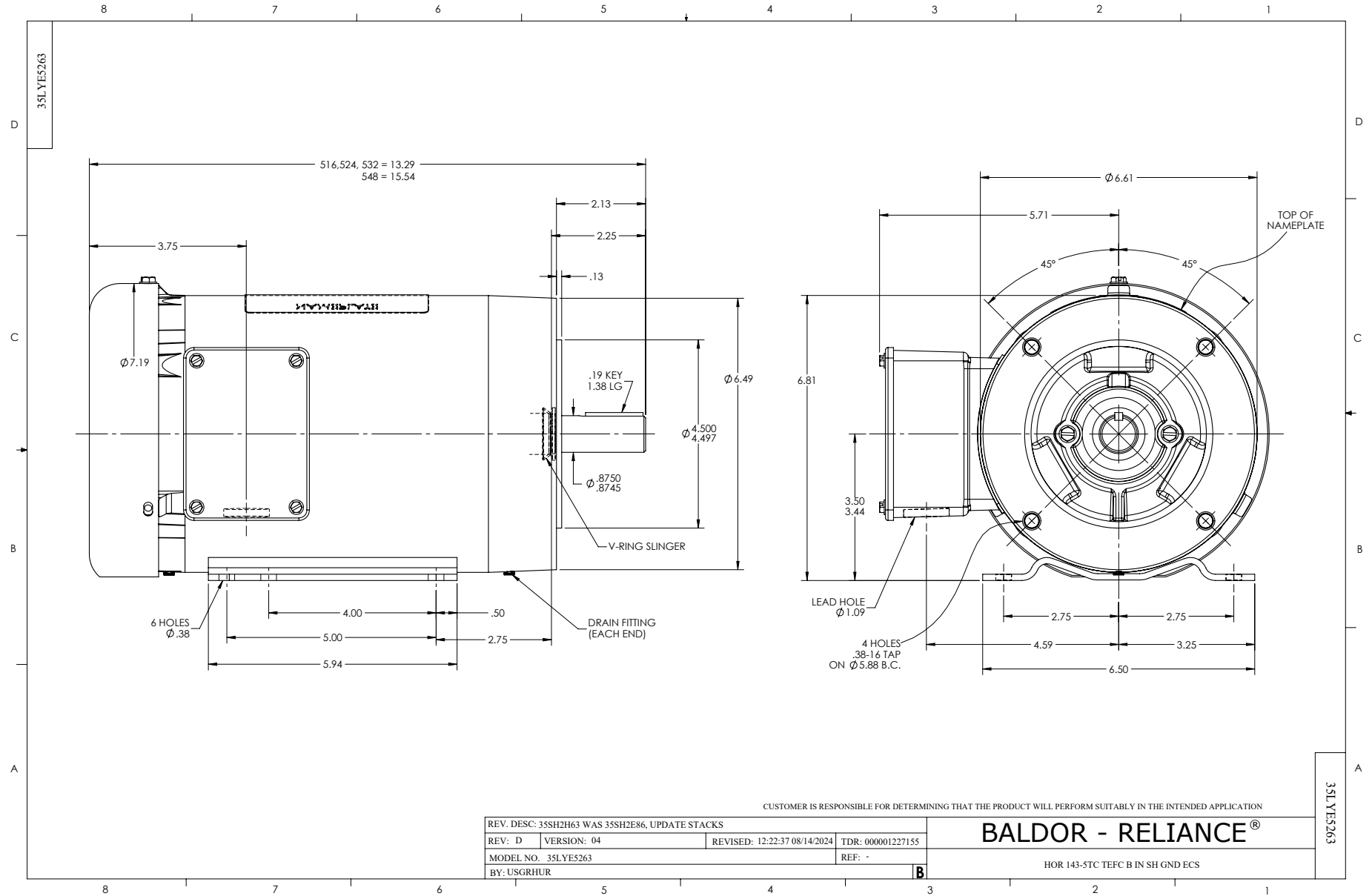

CD0005A25

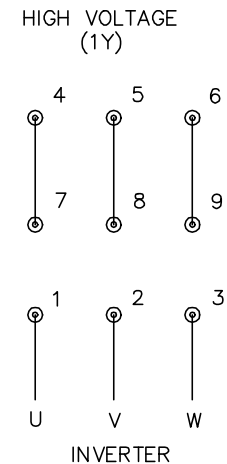
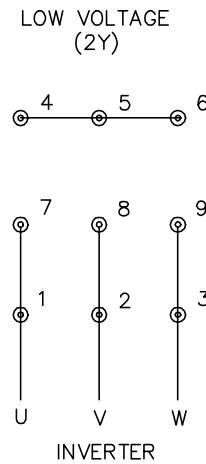
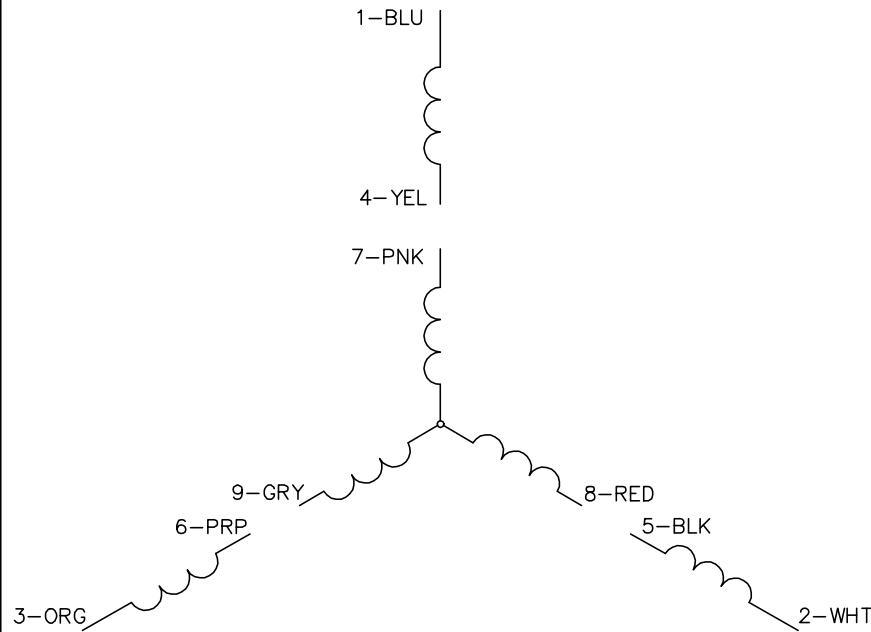

NOTES:

1. INTERCHANGE ANY TWO LINE LEADS TO REVERSE ROTATION.
2. ACTUAL NUMBER OF INTERNAL PARALLEL CIRCUITS MAY BE A MULTIPLE OF THOSE SHOWN ABOVE.
3. LEAD COLORS ARE OPTIONAL. LEADS MUST ALWAYS BE NUMBERED AS SHOWN.

CD0005A25

REV. DESC: NEW		
REV. LTR: -	VERSION: 00	TDR: 000001135746
FILE: \AAA\00253\082	REVISED: 01:10:57 03/30/2020	BY: ENMARSO
MTL: -	© □	

BALDOR - RELIANCE®

3PH, DV, 9 LEADS, ECS
SH 1 of 1