

BALDOR® • RELIANCE™

Customer information packet

ECR92506TR-4

250HP, 1190RPM, 3PH, 60HZ, 449T, A44160M, TEFC

Class - None

Division - Not Applicable

Specifications

Enclosure	TEFC
Frame	449T
Frame Material	Iron
Frequency	60.00 Hz
Haz Area Class and Group	None
Haz Area Division	Not Applicable
Motor Letter Type	Three Phase
Output @ Frequency	250.000 HP @ 60 HZ
Phase	3
Synchronous Speed @ Frequency	1200 RPM @ 60 HZ
Voltage @ Frequency	460.0 V @ 60 HZ
Agency Approvals	CCSAUSEEV
Ambient Temperature	40 °C
Auxillary Box	No Auxillary Box
Base Indicator	Rigid
Bearing Grease Type	Mobil SHC 220 (Athens Only)
Constant Torque Speed Range	30-60
Current @ Voltage	283.000 A @ 460.0 V
Design Code	A
Drip Cover	No Drip Cover
Duty Rating	CONT
Efficiency @ 100% Load	95.8 %
Feedback Device	NO FEEDBACK
Heater Indicator	No Heater
High Voltage Full Load Amps	283.0 a
Insulation Class	F
Inverter Code	Inverter Ready
KVA Code	H
Lifting Lugs	No Lifting Lugs
Max Speed	3000 rpm
Motor Lead Quantity/Wire Size	6 @ 1/0 AWG
Motor Standards	Other

Part detail

Revision	F
Type	AC
Mech. spec.	
Base	
Status	PRD/A
Elec. spec.	A44WG5114
Layout	617427-091
Eff. date	04-08-2021
CD Diagram	416820-036
Poles	06
Leads	3#1/0 (02 per group)
Proprietary	False
Created date	02-05-2015

Motor Type	A44160M
Mounting Arrangement	F1
Number of Poles	6
Overall Length	53.24 IN
Power Factor	85
Product Family	Crusher / Chipper
Pulley End Bearing Type	Roller
Pulley Face Code	Standard
Service Factor	1.15
Shaft Diameter	3.375 IN
Shaft Ground Indicator	No Shaft Grounding
Shaft Rotation	Reversible
Shaft Slinger Indicator	Shaft Slinger
Speed	1190 rpm
Speed Code	Single Speed
Starting Method	Direct on line
Thermal Device - Bearing	None
Thermal Device - Winding	None

Nameplate

000613007PV

CAT NO	ECR92506TR-4	SPEC NO.	P44G1817							
HP	250	AMPS	283	VOLTS	460	DESIGN	A			
RPM	1190	RPM MAX	3000	HZ	60	AMB	40	SF	1.15	
D.E. BRG.DATA	NU222	O.D.E. BRG.DATA	6318		PH	3	DUTY	CONT	INSUL.CLASS	F
FRAME	449T	I.P.	55	TYPE	P	ENCL	TEFC	CODE	H	
POWER FACTOR	85	3/4 LOAD EFF.	95.9		NEMA NOM EFFICIENCY	95.8				
CHP HZ	60-90	CT HZ	30-60	VT HZ	6-60					
SER.NO.			MOTOR WEIGHT	3225						

NP2496L

MOBIL SHC -220 GREASE

617427-091

DUTY MASTER ALTERNATING CURRENT MOTORS

SQUIRREL-CAGE INDUCTION

ENCLOSURE: TOTALLY ENCLOSED

FRAME 449T ABOVE NEMA RATINGS

COOLING: FAN COOLED

MOUNTING: FOOT

INCLUDES 447T FRAME MOUNTING HOLES

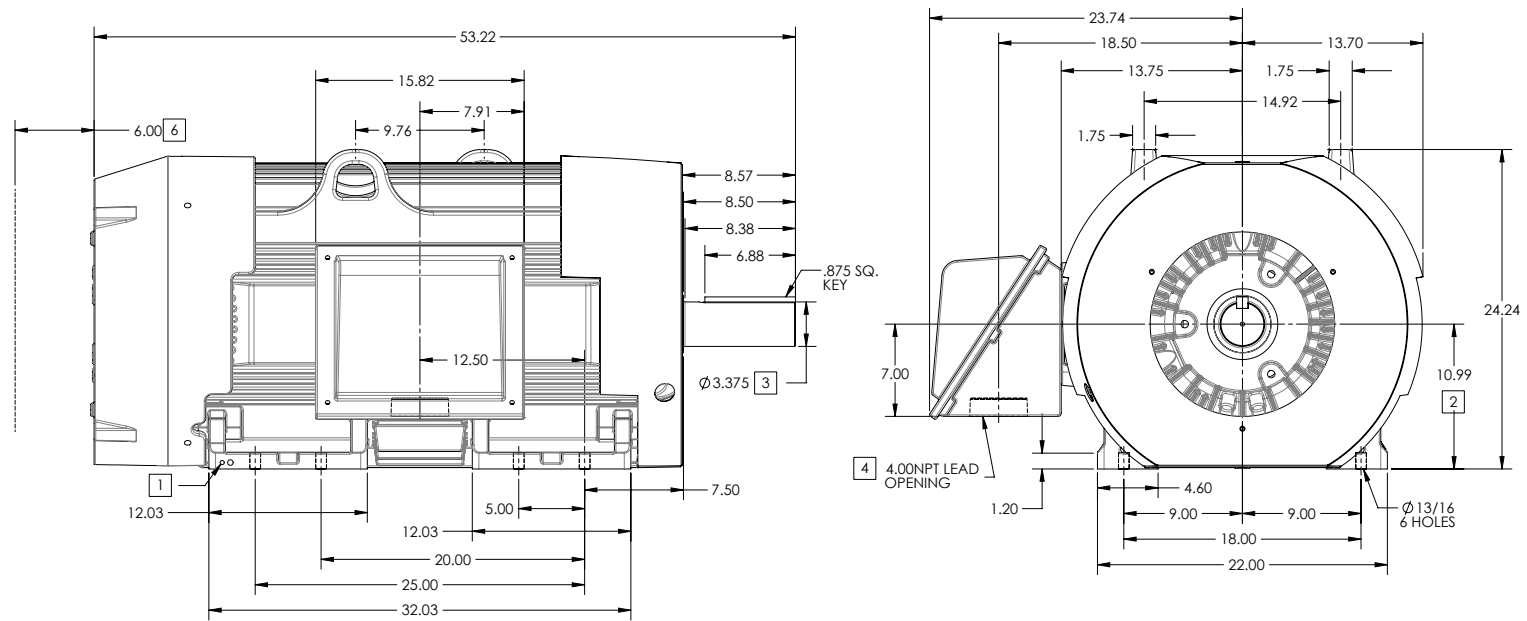

- 1. GROUND HOLES QTY 1 1/2-13 TAP; QTY 1 3/8-16 TAP
- 2. VARIES +.01, -.05
- 3. VARIES +.000, -.001
- 4. ON STANDARD MOTORS THIS IS CONDUIT SIZE. ON XT AND CORROSION PROOF MOTOR THIS IS PIPE TAP.
- 5. MOTOR WEIGHTS MAY VARY BY 1.5% DEPENDING ON RATING.
- 6. OBSTRUCTION MUST NOT ENCR OACH ON AIR INLET

CONDUIT BOX LOCATED ON OPPOSITE SIDE WHEN F-2.
 IF MOUNTING CLEARANCE DETAILS ARE REQUIRED, CONSULT FACTORY.
 MAXIMUM PERMISSIBLE SHAFT RUNOUT WHEN MEASURED AT END OF
 STANDARD SHAFT EXTENSION IS .003" T.I.R. TO 5 INCH DIA.

[5] WEIGHT (LBS): 3080

DRIVE END AIR DEFLECTOR IS ONLY INCLUDED WHEN NECESSARY.

DIMENSIONS ARE IN INCHES

CUSTOMER IS RESPONSIBLE FOR DETERMINING THAT MOTOR PERFORMANCE IS SUITABLE IN THE APPLICATION.

SHEET NUMBER
1 OF 2

1607-27-119

REV. DESC: ADD C DIMENSION	REVISED: 02-45-42 09/29/2015	TDR: 00000942902
REV: B	VERSION: 02	
MODEL NO. 617427-091		
BY: USBRCHA2		

BALDOR

G449/447T SIDE MOUNT C-BOX, TEFC

617427-091

617427-091

DUTY MASTER ALTERNATING CURRENT MOTORS

SQUIRREL-CAGE INDUCTION

ENCLOSURE: TOTALLY ENCLOSED

FRAME 449T ABOVE NEMA RATINGS

COOLING: FAN COOLED

MOUNTING: FOOT

INCLUDES 449T FRAME MOUNTING HOLES

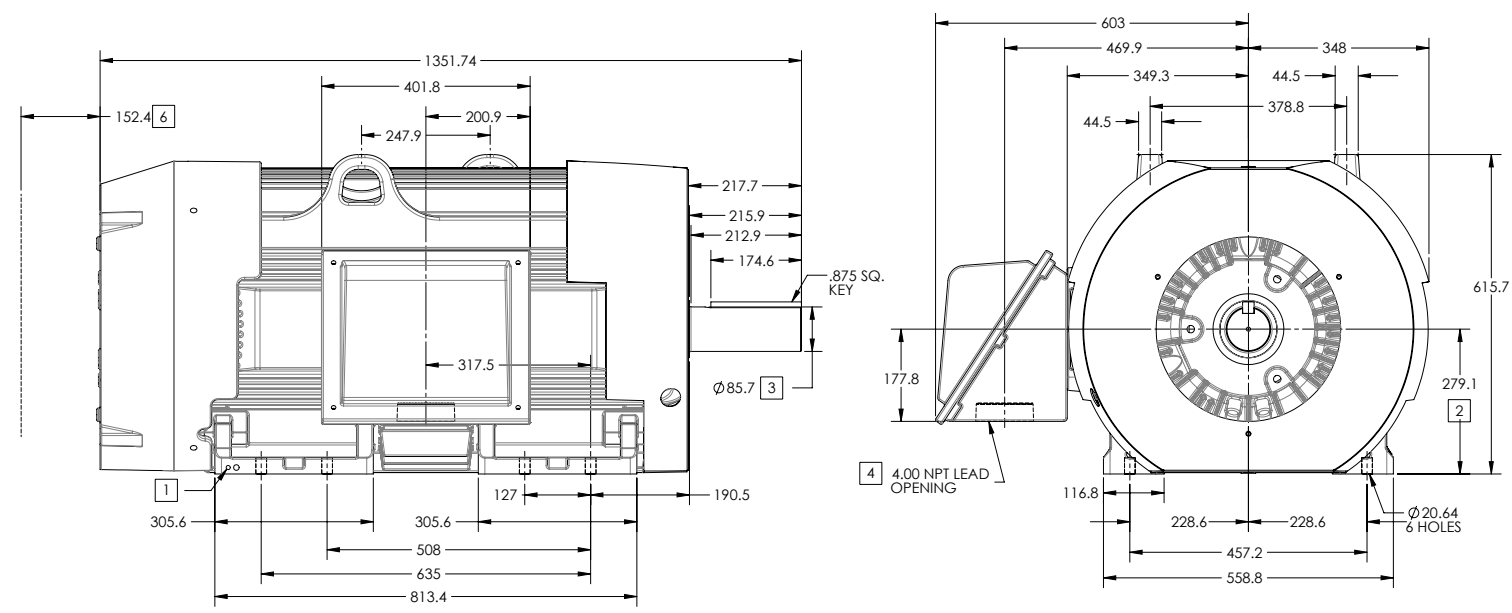

- 1. GROUND HOLES QTY 1 1/2-13 TAP; QTY 1 3/8-16 TAP
- 2. VARIES +.00,-1.524
- 3. VARIES +.000,-.0254
- 4. ON STANDARD MOTORS THIS IS CONDUIT SIZE. ON XT AND CORROSION PROOF MOTOR THIS IS PIPE TAP.
- 5. MOTOR WEIGHTS MAY VARY BY 15% DEPENDING ON RATING.
- 6. OBSTRUCTION MUST NO ENCROACH ON AIR INLET

5 MASS (KGS): 1395

DRIVE END AIR DEFLECTOR IS ONLY INCLUDED WHEN NECESSARY.

DIMENSIONS ARE IN MILLIMETERS, SEE SHEET 1 FOR DIMENSIONS IN INCHES

CUSTOMER IS RESPONSIBLE FOR DETERMINING THAT MOTOR PERFORMANCE IS SUITABLE IN THE APPLICATION.

CONDUIT BOX LOCATED ON OPPOSITE SIDE WHEN F-2.
IF MOUNTING CLEARANCE DETAILS ARE REQUIRED, CONSULT FACTORY.
MAXIMUM PERMISSIBLE SHAFT RUNOUT WHEN MEASURED AT END OF
STANDARD SHAFT EXTENSION IS .0762 T.I.R. TO 127 MM DIA.

SHEET NUMBER
2 OF 2

1607-27-119

REV. DISC: ADD C DIMENSION			
REV: B	VERSION: 02	REVISED: 02-45-42 09/29/2015	TDR: 00000942902
MODEL NO. 617427-091			
BY: USBRCHA2			

BALDOR

G449/447T SIDE MOUNT C-BOX, TEFC

617427-091

416820-036

A-C MOTOR
CONNECTION DIAGRAM
STANDARD 3 LEAD CONNECTED

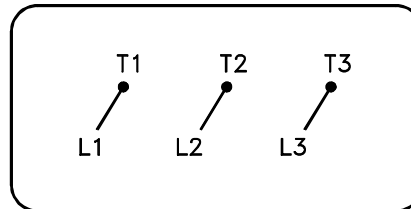

(N.P. 1575-BA)

416820-036

REV. DESC: LOADED TO BUS, C/R 335225		
REV. LTR: -	VERSION: 00	TDR: 000000538207
FILE: \MGA\00000\682	REVISED: 11: 54: 06 04/30/2010	
MTL: -	BY: RAGRA	

BALDOR

CONN DIAG - STANDARD 3 LEAD
SH 1 of 1