

<b>ABB Oy</b> <b>Motors &amp; Generators</b>		Classifying code or document type <b>PERFORMANCE DATA OF MOTOR</b>				
Department/Author <b>MLA000/TISA</b>	Date of issue <b>11.10.2018</b>	Lang. <b>En</b>	Rev. date	Our ref. <b>3GZF021035-1238</b>		
Customer ref.	Saving Ident <b>TMAA-ASUG9J-TISA32</b>			Rev./Changed by <b>A</b>	Pages <b>1/3</b>	

Driven Motor:

Catalog Number	<b>ECR585004-PPN</b>			
Motor type code	<b>M3BN 587 MLA 4K</b>			
Motor product code	<b>3GBN982410-ADKBA05</b>			
Motor type	<b>Squirrel cage Motor</b>			
Mounting designation	<b>IM 1001 (B3)</b>			
Protected by enclosure	<b>IP66</b>			
Method of cooling	<b>TEFC</b>			
Insulation	<b>Class F (Shock Resistant)</b>			
Service factor	<b>SF1.15 TEMP RISE CLASS F</b>			
Standards	<b>NEMA</b>			
International efficiency classification (IEC 60034-30)	<b>IE3</b>			
Ambient temperature, max.	<b>40 °C</b>			
Altitude, max.	<b>3280 ft.a.s.l.</b>			
Duty type	<b>Continuous</b>			
Temp. rise	<b>Class B</b>			
Connection of stator winding	<b>Delta</b>			
Rated output	<b>500 HP</b>			
Voltage	<b>460 V</b>			
Frequency	<b>60 Hz</b>			
Speed	<b>1791 r/min</b>			
Current	<b>576 Amps</b>			
Locked rotor Amps	<b>780 % Code J</b>			
Locked rotor torque	<b>280 %</b>			
Breakdown torque	<b>310 %</b>			
No load current	<b>208 Amps</b>			
Rated torque	<b>1466 lb-ft</b>			
Load characteristics	Load %	Current Amps	Efficiency %	Power Factor
	100	576	96,2	0,84
	75	453	96,5	0,80
	50	340	96,0	0,71
NEMA nominal efficiency	<b>96,2 %</b>			

Typical calculated values to NEMA. -

## ABB Oy

Motors & Generators Visiting Address  
Strömbergin puistotie 5 A  
VAASA  
FINLAND

Postal Address  
P.O.Box 633  
FI-65101 VAASA  
FINLAND

Telephone  
+358 10 222 000

Telefax  
+358 10 224 7372

<b>ABB Oy</b> Motors & Generators		Classifying code or document type			<b>PERFORMANCE DATA OF MOTOR</b>		<b>ABB</b>	
Department/Author MLA000/TISA	Date of issue 11.10.2018	Lang. En	Rev. date	Our ref. 3GZF021035-1238				
Customer ref.			Saving Ident TMAA-ASUG9J-TISA32	Rev./Changed by A	Pages 2/3			

Motor type code: M3BN 587 MLA 4K

Rated output	500 HP	Power Factor	0,84
Voltage	460 V	Rated torque	1466 lb-ft
Frequency	60 Hz	Locked rotor Amps	780 %
Speed	1791 r/min	Locked rotor torque	280 %
Current	576 Amps	Breakdown torque	310 %

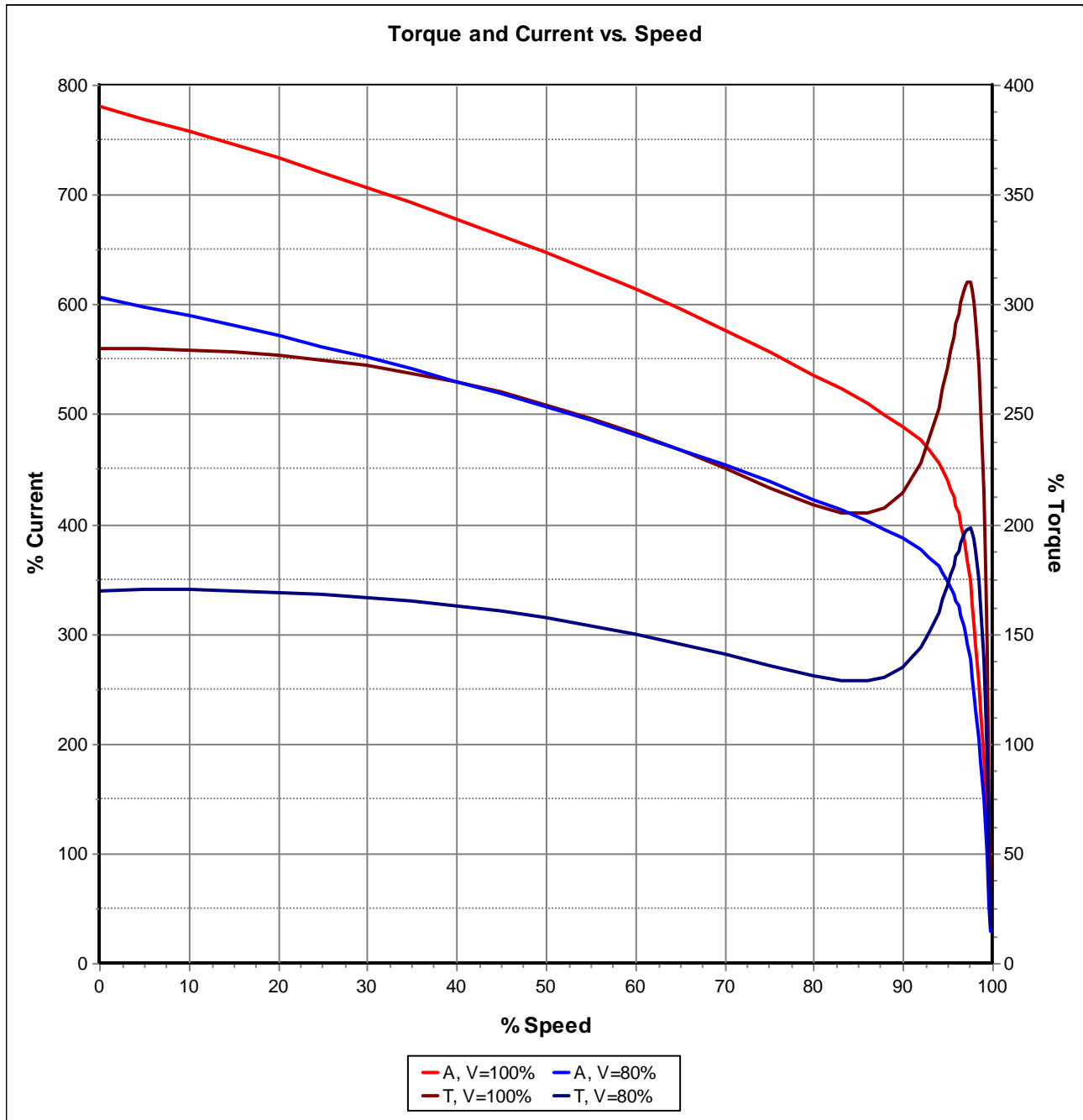

## ABB Oy

Motors & Generators  
 Visiting Address  
 Strömbergin puistotie 5 A  
 VAASA  
 FINLAND

Postal Address  
 P.O.Box 633  
 FI-65101 VAASA  
 FINLAND

Telephone      Telefax  
 +358 10 222 000    +358 10 224 7372

<b>ABB Oy</b> <b>Motors &amp; Generators</b>		Classifying code or document type <b>PERFORMANCE DATA OF MOTOR</b>				
Department/Author MLA000/TISA	Date of issue 11.10.2018	Lang. En	Rev. date	Our ref. 3GZF021035-1238		
Customer ref.	Saving Ident TMAA-ASUG9J-TISA32		Rev./Changed by A	Pages 3/3		

PWM  
Switch. freq. 3kHz  
FWP 460VD 60Hz  
VSD-duty: Temp. rise class F

#### Drive1

Rated power	125 HP
Rated voltage	117 V
Nominal frequency	15,3 Hz
Type of connection	Delta
Rated torque	1455 lb-ft
Speed	450 rpm
Current	574 Amps

#### Drive2

Rated power	500 HP
Rated voltage	460 V
Nominal frequency	60,4 Hz
Type of connection	Delta
Rated torque	1459 lb-ft
Speed	1800 rpm
Current	627 Amps

Constant torque 450 – 1800rpm

## ABB Oy

Motors & Generators Visiting Address  
Strömbergin puistotie 5 A  
VAASA  
FINLAND

Postal Address  
P.O.Box 633  
FI-65101 VAASA  
FINLAND

Telephone  
+358 10 222 000

Telefax  
+358 10 224 7372

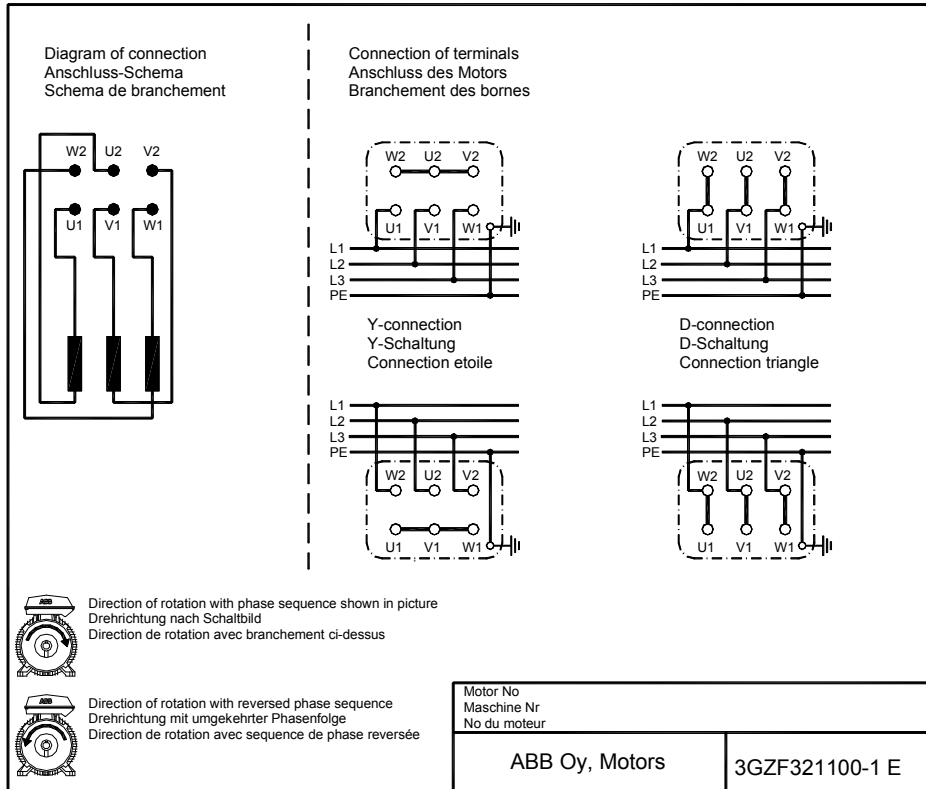

## Connection Diagram

Document No:  
3GZF321100-1 E

Description: 3-PHASE SQUIRREL-CAGE MOTOR

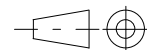

Unit: Motors

Issued by: M Prusi

Replaces:

Date: 21.09.2005

Approved by: Jari Raittila

Replaced by:

**ABB Oy**

Customer Reference:

**ABB**

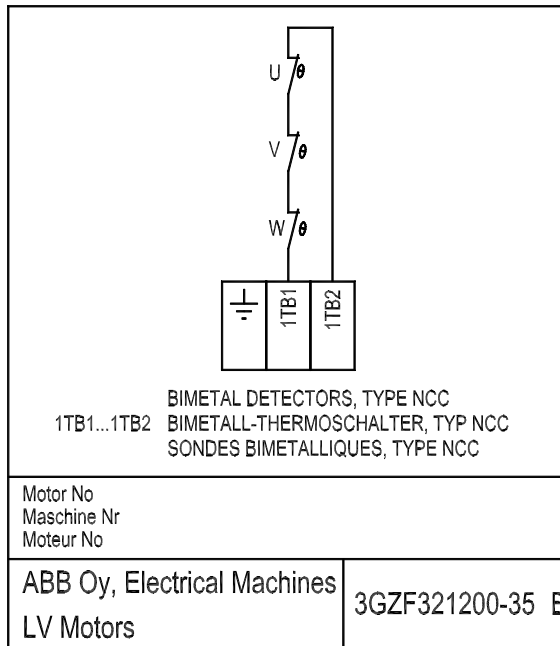

Motor No  
 Maschine Nr  
 Moteur No

ABB Oy, Electrical Machines  
 LV Motors

3GZF321200-35 B

**Accessory Connection Diagram**

Document No:  
 3GZF321200-35 B

Description: BIMETAL DETECTORS

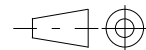

Unit: Electrical Machines, LV Motors

Issued by: K.Högvist

Replaces:

Date: 16.01.2002

Approved by: M.Prusi

Replaced by:

**ABB Oy**

Customer Reference:

**ABB**

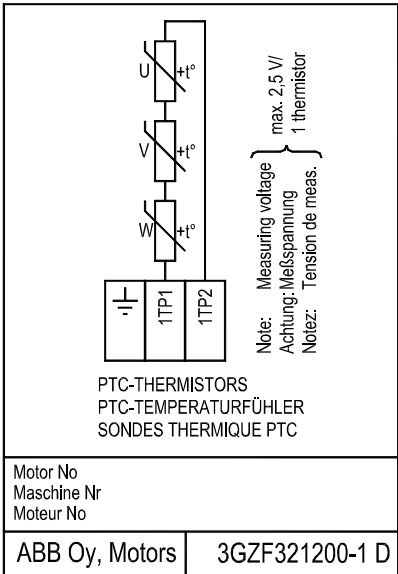

**Accessory Connection Diagram**

Document No:  
 3GZF321200-1 D

Description: PTC-THERMISTORS

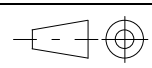

Unit: Motors	Issued by: K.Högvist	Replaces:
Date: 30.11.2005	Approved by: M.Prusi	Replaced by:

<b>ABB Oy</b>	Customer Reference:	<b>ABB</b>
---------------	---------------------	------------

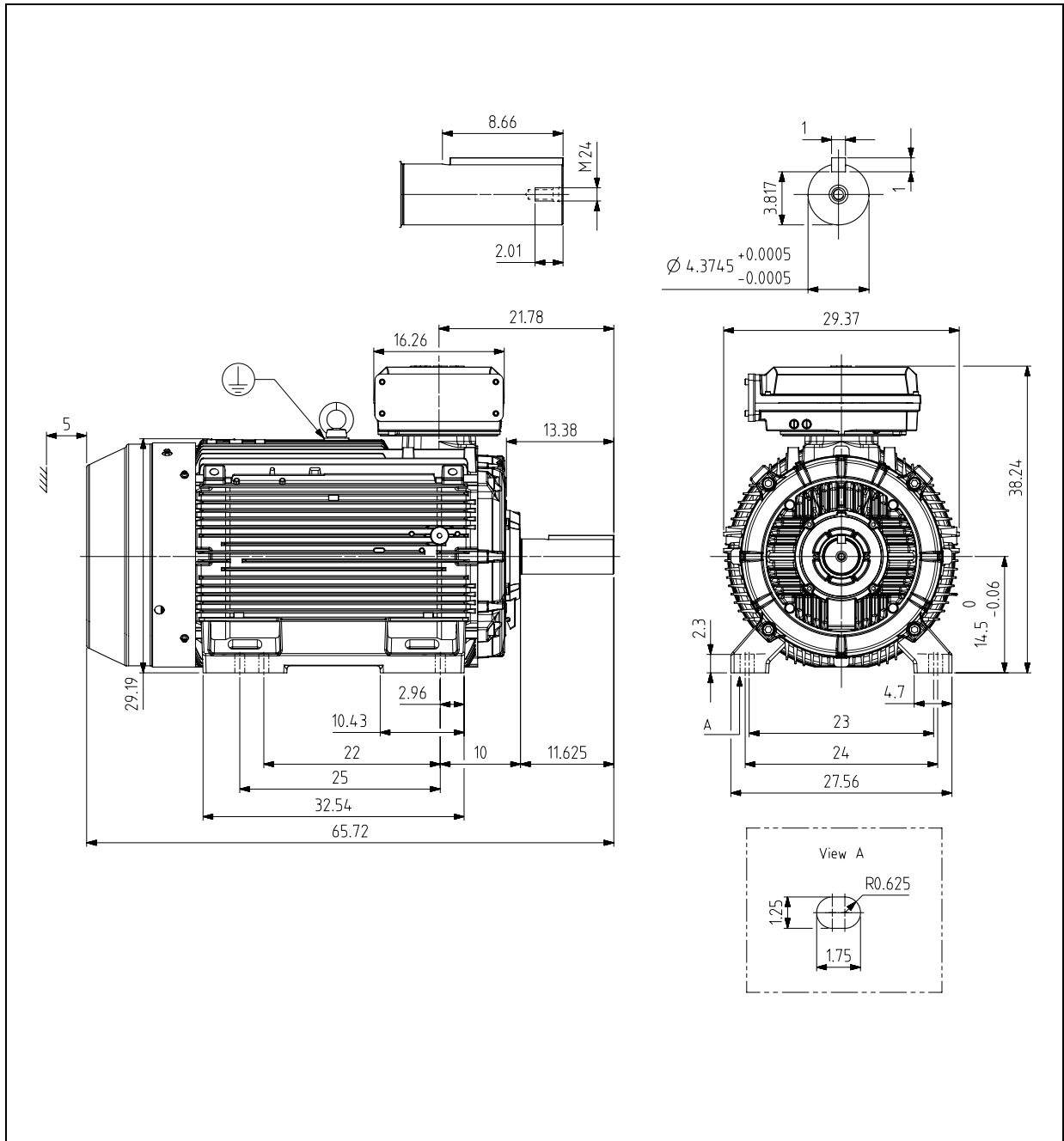

Additional information:

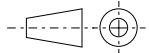
<b>Dimension Print</b>	Motor Type: M3BN 587ML_4.. B3, B6, B7, B8, V5, V6	Document No: 3GZF500098-174 A 14 BN 587 A
Description: SQUIRREL CAGE MOTOR, CABLE ENTRY LHS, SPECIAL SHAFT, SLOTTED FEET HOLES. DIMENSIONS IN INCHES, MOTOR SIZES 586/587.		
Unit: ABB Oy, Motors and Generators Date: 21.11.2019	Issued by: N.Palokangas Approved by: S.Tikkanen	Replaces: Replaced by:
<b>ABB Oy</b>	Customer Reference:	<b>ABB</b>