

BALDOR • RELIANCE

Customer information packet

ECP82276T-4

7.5HP, 1180RPM, 3PH, 60HZ, 254T, TEFC, F1

Class - CLI GP A,B,C,D

Division - Division II

Specifications

Enclosure	TEFC
Frame	254T
Frame Material	Iron
Frequency	60.00 Hz
Motor Letter Type	Three Phase
Output @ Frequency	7.500 HP @ 60 HZ
Phase	3
Synchronous Speed @ Frequency	1200 RPM @ 60 HZ
Voltage @ Frequency	460.0 V @ 60 HZ
XP Class and Group	CL I GP A,B,C,D
XP Division	Division II
Agency Approvals	CCSA US CSA EEV UR
Ambient Temperature	40 °C
Auxillary Box	No Auxillary Box
Auxillary Box Lead Termination	None
Base Indicator	Rigid
Bearing Grease Type	Polyrex EM (-20F +300F)
Blower	None
Constant Torque Speed Range	1
Current @ Voltage	10.500 A @ 460.0 V
Design Code	B
Drip Cover	No Drip Cover
Duty Rating	CONT
Efficiency @ 100% Load	91.0 %
Electrically Isolated Bearing	Not Electrically Isolated
Enclosure Modification	841
Feedback Device	NO FEEDBACK
Heater Indicator	No Heater
High Voltage Full Load Amps	10.5 a
Insulation Class	F

Part detail

Revision	J
Type	AC
Mech. spec.	
Base	
Status	PRD/A
Elec. spec.	09WGZ222
Layout	09LYJ287
Eff. date	06-22-2022
CD Diagram	CD0006
Poles	06
Leads	3#12
Proprietary	False
Created date	11-27-2018

Inverter Code	Inverter Duty
IP Rating	IP56
KVA Code	H
Lifting Lugs	Standard Lifting Lugs
Locked Bearing Indicator	Locked Bearing
Max Speed	1800 rpm
Motor Lead Termination	Ring Terminals
Motor Standards	NEMA
Motor Type	0954M
Mounting Arrangement	F1
Number of Poles	6
Overall Length	24.68 IN
Power Factor	71
Product Family	Chem Process S/P 32-8 IEEE 841
Pulley Face Code	Standard
Rodent Screen	None
Service Factor	1.15
Shaft Diameter	1.625 IN
Shaft Ground Indicator	No Shaft Grounding
Shaft Rotation	Reversible
Speed	1180 rpm
Speed Code	Single Speed
Starting Method	Direct on line
Thermal Device - Winding	None
Vibration Sensor Indicator	No Vibration Sensor
Winding Thermal 1	None
Winding Thermal 2	None
XP Temp Code	T3C

Nameplate

NP3190

STK.NO.	ECP82276T-4	P/N		ENCLOSURE	TEFC
SPEC.	09-0000-0857	CC	010A	FRAME	254T
HP	7.5	CLASS	F	HZ	60
RPM	1180	RPM MAX	1800	ODE BRG	6309
VOLT	460	PH	3	DE BRG	6309
AMP	10.5	DES	B	D.E. BRG.	45BC03X30X
RATING	40C AMB-CONT	KVA-CODE	H	O.D.E. BRG.	45BC03X30X
NEMA-NOM-EFF	91	MOTOR WEIGHT	343	GREASE	POLYREX EM
G.MIN.EFF	89.5	MAX. KVAR	4	BLANK	
TEMP CODE	T3C	# OF ROTOR BARS	27	SER.F.	1.15
TEMP =	160	# OF STATOR SLOTS	36	IP	56
CT HZ FROM	1	PF	71	INV.TYPE	PWM
HTR-VOLTS		INVERTER-TEMP-CODE	180		
HTR-AMPS		C HP FR	60	C HP TO	90
HTR-WATTS		CT HZ TO	60		
MAX. SPACE HEATER TEMP.				VT HZ FROM	0
				VT HZ TO	60

AC Induction Motor Performance Data

Record # 47082

Typical performance - not guaranteed values

Winding: 09WGX222-R018			Type: 0954M		Enclosure: TEFC	
Nameplate Data				460 V, 60 Hz: Single Voltage Motor		
Rated Output (HP)	7.5		Full Load Torque	32.4 LB-FT		
Volts	460		Start Configuration	direct on line		
Full Load Amps	10.5		Breakdown Torque	92 LB-FT		
R.P.M.	1180		Pull-up Torque	36.5 LB-FT		
Hz	60	Phase	3	Locked-rotor Torque	53.6 LB-FT	
NEMA Design Code	B		KVA Code	H	Starting Current	64.6 A
Service Factor (S.F.)	1.15		No-load Current	5.39 A		
NEMA Nom. Eff.	91	Power Factor	71	Line-line Res. @ 25°C	0.953 Ω	
Rating - Duty	40C		AMB-CONT	Temp. Rise @ Rated Load	31°C	
S.F. Amps				Temp. Rise @ S.F. Load	38°C	
				Locked-rotor Power Factor	25.7	
				Rotor inertia	4.34 LB-FT ²	

Load Characteristics 460 V, 60 Hz, 7.5 HP

% of Rated Load	25	50	75	100	125	150	S.F.
Power Factor	34	54	65	71	74	75	73
Efficiency	83.5	90.2	91.2	91.3	91.8	90.8	91.8
Speed	1196	1191	1188	1180	1177	1171	1179
Line amperes	5.92	7.13	8.57	10.5	12.7	15.6	11.8

ABB Motors and Mechanical Inc.

WINDING # 09WGZ222

Typical performance - not guaranteed values.

7.5 HP 3 PH 60 HZ 1180 RPM 460 V 0954M

TORQUES (LB-FT): PO=92 PU=36.5 LR=53.6 LRA=64.6

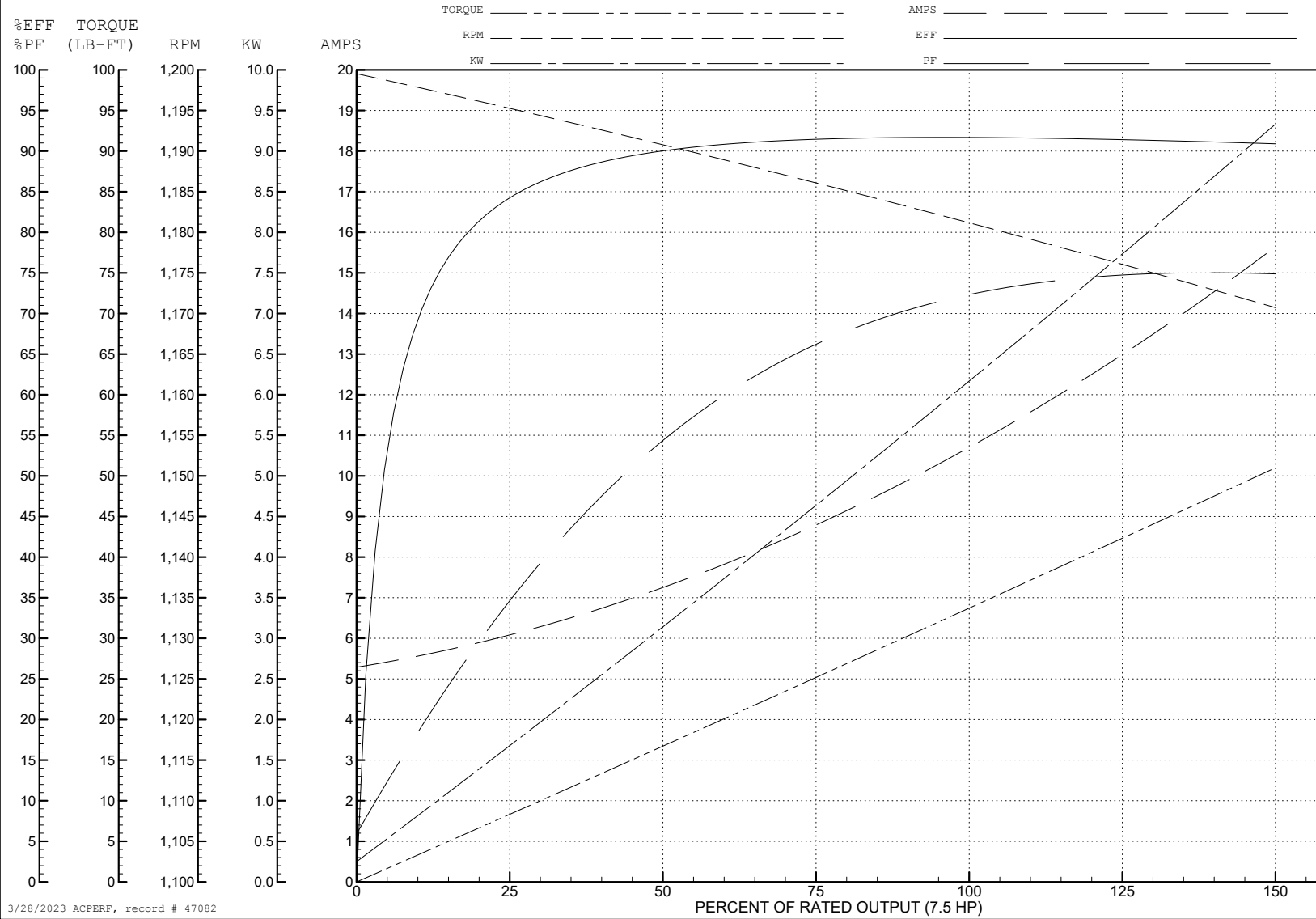

3/28/2023 ACPERF, record # 47082

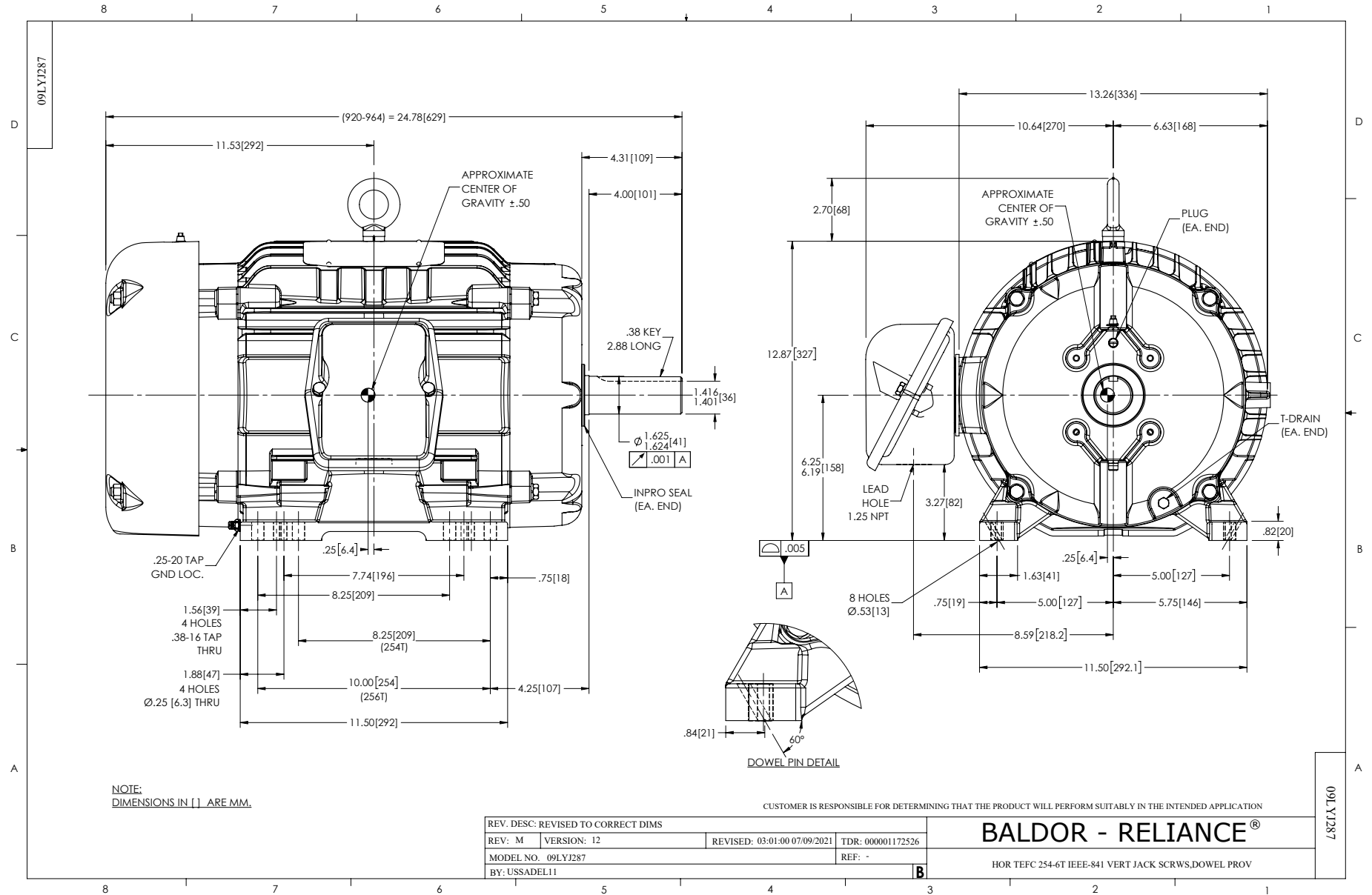

CD0006

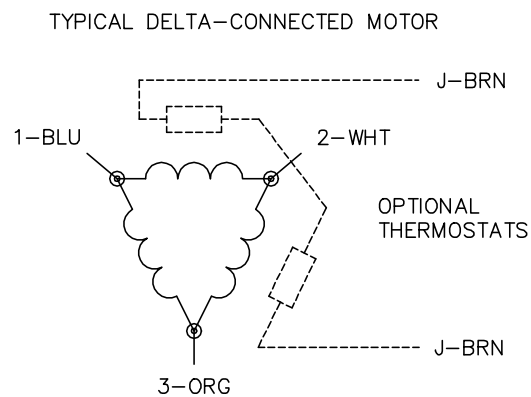

NOTES:

1. THREE LEAD MOTOR MAY BE EITHER WYE CONNECTED OR DELTA CONNECTED.
2. INTERCHANGE ANY TWO LINE LEADS TO REVERSE ROTATION.
3. OPTIONAL THERMOSTATS ARE PROVIDED WHEN SPECIFIED.
4. ACTUAL NUMBER OF INTERNAL PARALLEL CIRCUITS MAY VARY.
5. LEAD COLORS ARE OPTIONAL. LEADS MUST BE NUMBERED AS SHOWN.

CD0006

REV. DESC: ADD CLASS CONN00000007		
REV. LTR: E	VERSION: 01	TDR: 000001099922
FILE: \AAA\00005\141	REVISED: 10: 24: 49 02/19/2019	BY: ENBRIRO
MTL: -	© □	

BALDOR - RELIANCE®

3PH, SV, 3 LEADS, WYE OR DELTA CONNECTED

SH 1 of 1