

BALDOR® • RELIANCE™

Customer information packet

ECP4410T-5

125HP, 1785RPM, 3PH, 60HZ, 444T, A44076M, TEFC

Class - None

Division - Division II

Specifications

Enclosure	TEFC
Frame	444T
Frame Material	Iron
Frequency	60.00 Hz
Motor Letter Type	Three Phase
Output @ Frequency	125.000 HP @ 60 HZ
Phase	3
Synchronous Speed @ Frequency	1800 RPM @ 60 HZ
Voltage @ Frequency	575.0 V @ 60 HZ
XP Class and Group	None
XP Division	Division II
Agency Approvals	CSA EEV
Ambient Temperature	40 °C
Auxillary Box	No Auxillary Box
Base Indicator	Rigid
Bearing Grease Type	Polyrex EM (-20F +300F)
Constant Torque Speed Range	10-60
Current @ Voltage	115.000 A @ 575.0 V
Design Code	B
Drip Cover	No Drip Cover
Duty Rating	CONT
Efficiency @ 100% Load	95.4 %
Feedback Device	NO FEEDBACK
Heater Indicator	No Heater
High Voltage Full Load Amps	115.0 a
Insulation Class	F
Inverter Code	Not Inverter
KVA Code	G
Lifting Lugs	Standard Lifting Lugs
Motor Lead Quantity/Wire Size	3 @ 1 AWG
Motor Standards	NEMA
Motor Type	A44076M

Part detail

Revision	L
Type	AC
Mech. spec.	
Base	
Status	PRD/A
Elec. spec.	A44WG3904
Layout	617427-001
Eff. date	03-12-2020
CD Diagram	416820-036
Poles	04
Leads	3#1
Proprietary	False
Created date	08-15-2012

Mounting Arrangement	F1
Number of Poles	4
Overall Length	44.75 IN
Power Factor	85
Product Family	Other
Pulley End Bearing Type	Ball
Pulley Face Code	Standard
Service Factor	1.15
Shaft Ground Indicator	No Shaft Grounding
Shaft Rotation	Reversible
Shaft Slinger Indicator	No Slinger
Speed	1785 rpm
Speed Code	Single Speed
Starting Method	Direct on line
Thermal Device - Bearing	None
Thermal Device - Winding	None
XP Temp Code	T3

Nameplate

NP3238

CAT NO	ECP4410T-5	SPEC NO.	P44G3940						
HP	125	AMPS	115	VOLTS	575	DESIGN	B		
FRAME	444T	RPM	1785	HZ	60	AMB	40	SF	1.15
D.E. BRG.DATA	6318	O.D.E. BRG.DATA	6318	PH	3	DUTY	CONT	INSUL.CLASS	F
D.E. BRG.	90BC03J30X	TYPE	P	ENCL	TEFC	CODE	G		
O.D.E. BRG.	90BC03J30X	POWER FACTOR	85	NEMA NOM EFFICIENCY	95.4				
3/4 LOAD EFF.	95.8	MAX CORR KVAR	27.0	GUARANTEED EFFICIENCY	94.5				
TEMP CODE	T3	TEMP =	200						
CHP HZ	60-90	CT HZ	10-60	VT HZ	0-60				
INVERTER-TEMP-CODE	T3								
SER.NO.		MOTOR WEIGHT	2054						

617427-001

DUTY MASTER ALTERNATING CURRENT MOTORS

SQUIRREL-CAGE INDUCTION

ENCLOSURE: TOTALLY ENCLOSED

FRAME G445T ABOVE NEMA RATINGS

COOLING: FAN COOLED

MOUNTING: FOOT

INCLUDES 444T FRAME MOUNTING HOLES

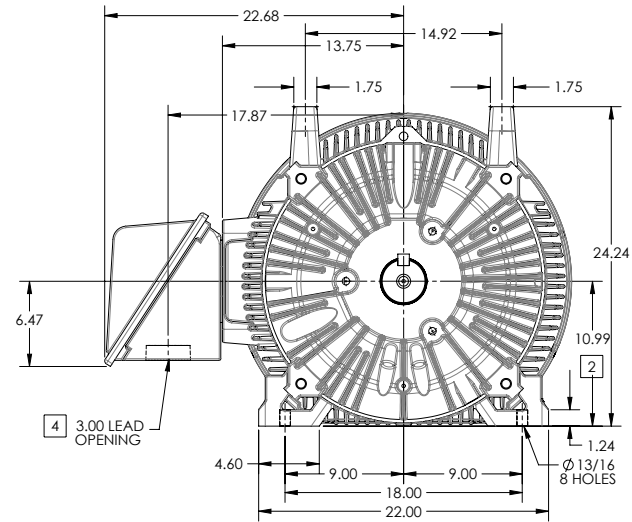
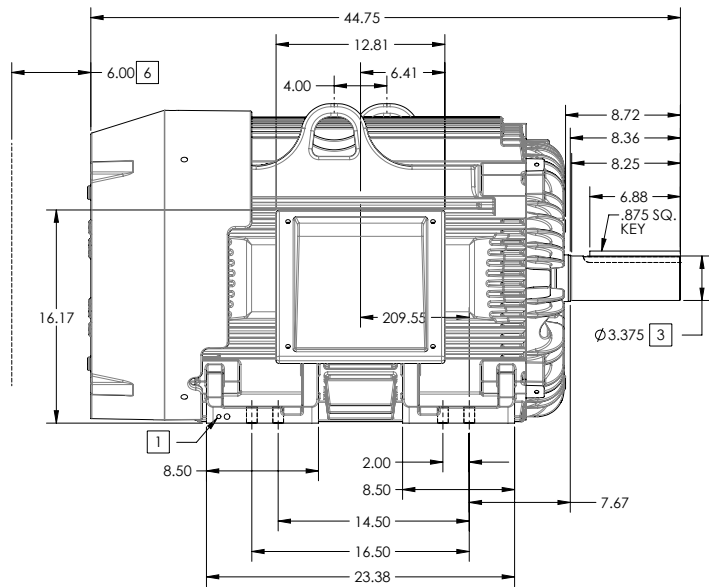

1. GROUND HOLES QTY 1 1/2-13 TAP; QTY 1 3/8-16 TAP
2. VARIES +.00,-.06
3. VARIES +.00,-.001
4. ON STANDARD MOTORS THIS IS CONDUIT SIZE. ON XT AND CORROSION PROOF MOTOR THIS IS PIPE TAP.
5. MOTOR WEIGHTS MAY VARY BY 15% DEPENDING ON RATING.
6. OBSTRUCTION MUST NOT ENCROACH ON AIR INLET

CONDUIT BOX LOCATED ON OPPOSITE SIDE WHEN F-2.
IF MOUNTING CLEARANCE DETAILS ARE REQUIRED, CONSULT FACTORY.
MAXIMUM PERMISSIBLE SHAFT RUNOUT WHEN MEASURED AT END OF
STANDARD SHAFT EXTENSION IS .003" T.I.R. TO 5 INCH DIA.

[5] WEIGHT (LBS): 2130

DRIVE END AIR DEFLECTOR IS ONLY INCLUDED WHEN NECESSARY.

DIMENSIONS ARE IN INCHES; SEE SHEET 2 FOR DIMENSIONS IN MILLIMETERS

CUSTOMER IS RESPONSIBLE FOR DETERMINING THAT MOTOR PERFORMANCE IS SUITABLE IN THE APPLICATION.

SHEET NUMBER
1 OF 2

100-2727-119

REV. DESC SHEET 2 NEEDS METRIC FOOT HOLE DIMENSION			
REV: E	VERSION: 05	REVISED: 09-22-56 06/12/2014	TDR: 00000857938
MODEL NO. 617427-001			REF:
BY: RAGRA	Material:		

BALDOR

G445T444T STD - FOOTED - SIDE CENTER CB

617427-001

617427-001

DUTY MASTER ALTERNATING CURRENT MOTORS

SQUIRREL-CAGE INDUCTION

ENCLOSURE: TOTALLY ENCLOSED

FRAME G445T ABOVE NEMA RATINGS

COOLING: FAN COOLED

MOUNTING: FOOT

INCLUDES 444T FRAME MOUNTING HOLES

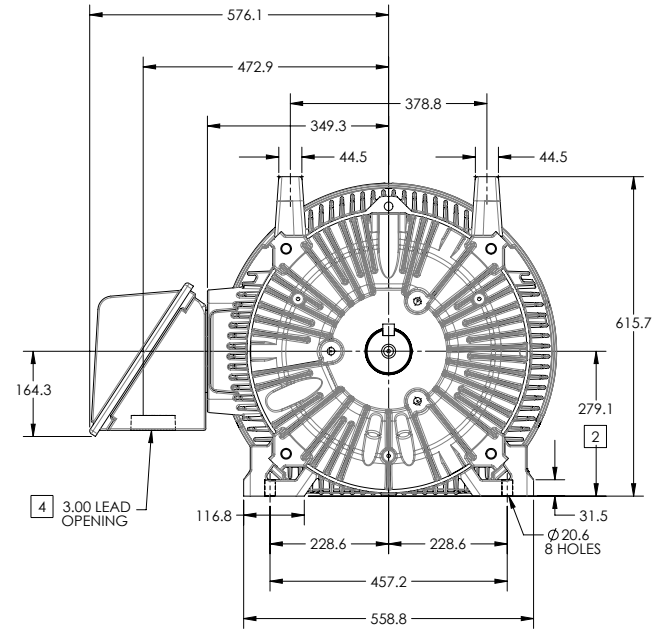
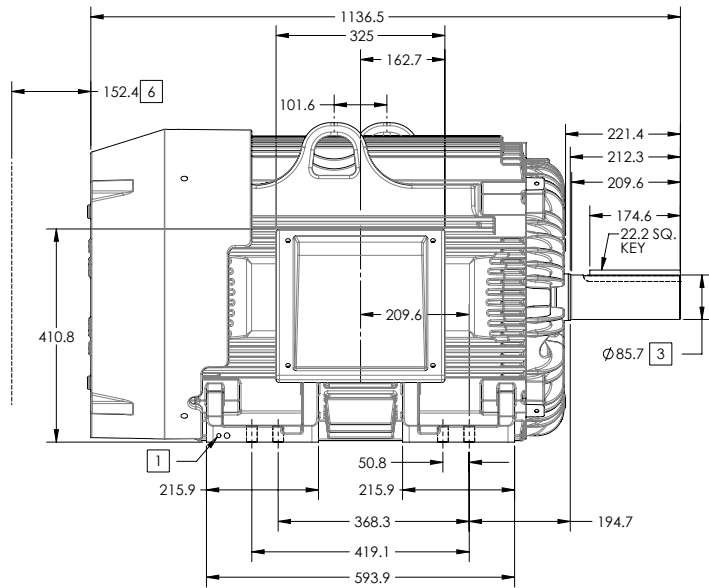

- 1. GROUND HOLES QTY 1 1/2-13 TAP; QTY 1 3/8-16 TAP
- 2. VARIES +0,-1.5
- 3. VARIES +.00,-.03
- 4. ON STANDARD MOTORS THIS IS CONDUIT SIZE. ON XT AND CORROSION PROOF MOTOR THIS IS PIPE TAP.
- 5. MOTOR WEIGHTS MAY VARY BY 15% DEPENDING ON RATING.
- 6. OBSTRUCTION MUST NOT ENCROACH ON AIR INLET

CONDUIT BOX LOCATED ON OPPOSITE SIDE WHEN F-2. IF MOUNTING CLEARANCE DETAILS ARE REQUIRED, CONSULT FACTORY. MAXIMUM PERMISSIBLE SHAFT RUNOUT WHEN MEASURED AT END OF STANDARD SHAFT EXTENSION IS .08 MM T.I.R. TO 127 MM DIA.

[5] WEIGHT (KGS): 970

DRIVE END AIR DEFLECTOR IS ONLY INCLUDED WHEN NECESSARY.

DIMENSIONS ARE IN MILLIMETERS; SEE SHEET 1 FOR DIMENSIONS IN INCHES

CUSTOMER IS RESPONSIBLE FOR DETERMINING THAT MOTOR PERFORMANCE IS SUITABLE IN THE APPLICATION.

SHEET NUMBER
2 OF 2

100-LCFL19

REV. DESC SHEET 2 NEEDS METRIC FOOT HOLE DIMENSION			
REV: E	VERSION: 05	REVISED: 09-22-56 06/12/2014	TDR: 00000857938
MODEL NO. 617427-001		REF:	
BY: RAGRA	Material:	C	

BALDOR

G445T444T STD - FOOTED - SIDE CENTER C/B

617427-001

416820-036

A-C MOTOR
CONNECTION DIAGRAM
STANDARD 3 LEAD CONNECTED



(N.P. 1575-BA)

416820-036

REV. DESC: LOADED TO BUS, C/R 335225		
REV. LTR: -	VERSION: 00	TDR: 000000538207
FILE: \MGA\00000\682	REVISED: 11:54:06 04/30/2010	
MTL: -	BY: RAGRA	

BALDOR

CONN DIAG - STANDARD 3 LEAD
SH 1 of 1