

DUTY MASTER ALTERNATING CURRENT MOTORS

SQUIRREL-CAGE INDUCTION

ENCLOSURE: TOTALLY ENCLOSED
MOUNTING: FOOT

COOLING: FAN COOLED

FRAMES 447T - 449TS ABOVE NEMA RATINGS
WITH PADDLE FAN AND GRILL B.E.

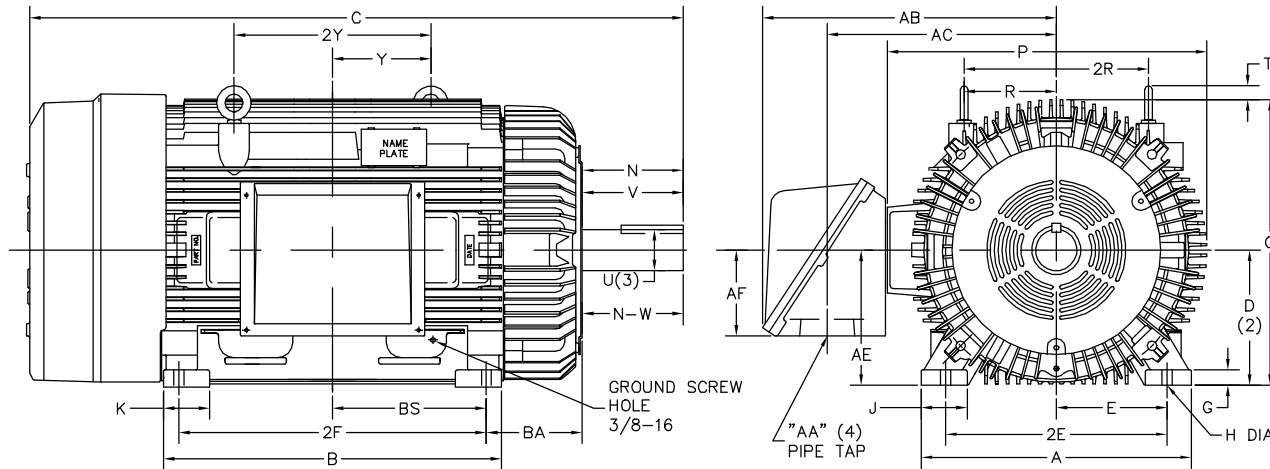

DIMENSIONS ARE IN MILLIMETERS; SEE SHEET 1 FOR DIMENSIONS IN INCHES

FRAME	A	D(2)	E	G	H	J	O	P	BA	K	T	Y	R	AA (4)	AE	STANDARD C/BOX		
																AB	AC	AF
447T	558.8	279.4	228.6	31.8	20.6	95.3	599.9	660.4	198.4	95.3	19.1	139.7	190.5	4 IN.	279.4	606.3	472.9	177.8
447TS	558.8	279.4	228.6	31.8	20.6	95.3	599.9	660.4	198.4	95.3	19.1	139.7	190.5	4 IN.	279.4	606.3	472.9	177.8
449T	558.8	279.4	228.6	31.8	20.6	95.3	599.9	660.4	198.4	95.3	19.1	203.2	190.5	4 IN.	279.4	606.3	472.9	177.8
449TS	558.8	279.4	228.6	31.8	20.6	95.3	599.9	660.4	198.4	95.3	19.1	203.2	190.5	4 IN.	279.4	606.3	472.9	177.8

- (1) SPECIAL DIMENSIONS ON THIS LINE.
- (2) "D" VARIES +.00,-.06
- (3) "U" AND "FU" VARY +.000,-.001
- (4) ON STANDARD MOTORS "AA" IS CONDUIT SIZE
ON XT AND CORROSION PROOF MOTOR "AA" IS PIPE TAP.
- (5) MOTOR WEIGHTS MAY VARY BY 15% DEPENDING ON RATING.

FRAME	C	BS	B	2F	BACK END SHAFT AND KEY				SQ. KEY	WT. (5) KGS.	
					N	N-W	U(3)	V			LGTH.
447T	1229.4	254.0	571.5	508.0	205.7	205.7	85.73	205.7	174.8	22.23	1032
447TS	1134.1	254.0	571.5	508.0	111.8	111.8	60.33	111.8	76.2	15.88	1032
449T	1356.4	317.5	698.5	635.0	205.7	205.7	85.73	205.7	174.8	22.23	1202
449TS	1261.1	317.5	698.5	635.0	111.8	111.8	60.33	111.8	76.2	15.88	1202

CONDUIT BOX LOCATED ON OPPOSITE SIDE WHEN F-2, W-1, W-4, W-5, W-7, OR C-1 MOUNTING IS SPECIFIED. STANDARD DOUBLE SHAFT SUPPLIED ONLY WHEN SPECIFIED. IF MOUNTING CLEARANCE DETAILS ARE REQUIRED CONSULT FACTORY. MAXIMUM PERMISSIBLE SHAFT RUNOUT WHEN MEASURED AT END OF STANDARD SHAFT EXTENSION IS .003 T.I.R. TO 5 INCH DIA.

CUSTOMER IS RESPONSIBLE FOR DETERMINING THAT MOTOR PERFORMANCE IS SUITABLE IN THE APPLICATION.

REV. DESC: LOADED INTO BUS PREVIOUS C/R 322843-460			Baldor • Dodge • Reliance
REV. LTR: -	VERSION: 00	TDR: 000000436566	
FILE: \RAG\00000\920	REVISED: 13:05:46 07/02/2007	BY: RAGEC	
MTL: -			

DIM SHEET 447/449 TEFC ABOVE NEMA WITH PADDLE FAN & GRILL BE