



Customer information packet

ECP3583T

1.5HP, 3450RPM, 3PH, 60HZ, 143T, 0524M, TEFC, F

Class - CLI GP A,B,C,D

Division - Division II

Specifications

Enclosure	TEFC
Frame	143T
Frame Material	Iron
Frequency	60.00 Hz
Haz Area Class and Group	CL I GP A,B,C,D
Haz Area Division	Division II
Motor Letter Type	Three Phase
Output @ Frequency	1.500 HP @ 60 HZ
Phase	3
Synchronous Speed @ Frequency	3600 RPM @ 60 HZ
Voltage @ Frequency	208.0 V @ 60 HZ 230.0 V @ 60 HZ 460.0 V @ 60 HZ
Agency Approvals	CCSA US CSA EEV NEMA PREMIUM NEMA_PREMIUM UR
Ambient Temperature	40 °C
Auxillary Box	No Auxillary Box
Auxillary Box Lead Termination	None
Base Indicator	Rigid
Bearing Grease Type	Polyrex EM (-20F +300F)
Blower	None
Constant Torque Speed Range	6
Current @ Voltage	4.000 A @ 230.0 V 4.300 A @ 208.0 V 2.000 A @ 460.0 V
Design Code	B
Drip Cover	No Drip Cover
Duty Rating	CONT
Efficiency @ 100% Load	85.5 %

Part detail

Revision	AA
Type	AC
Mech. spec.	05F008
Base	
Status	PRD/A
Elec. spec.	05WGW116
Layout	05LYF008
Eff. date	07-17-2023
CD Diagram	CD0005
Poles	02
Leads	9#18
Proprietary	False
Created date	02-24-2009

Electrically Isolated Bearing	Not Electrically Isolated
Feedback Device	NO FEEDBACK
Front Face Code	Standard
Front Shaft Indicator	None
Haz Area Temp Code	T4
Heater Indicator	No Heater
High Voltage Full Load Amps	2.0 a
Insulation Class	F
Inverter Code	Inverter Duty
KVA Code	M
Lifting Lugs	Standard Lifting Lugs
Locked Bearing Indicator	No Locked Bearing
Max Speed	5400 rpm
Motor Lead Exit	Ko Box
Motor Lead Quantity/Wire Size	9 @ 18 AWG
Motor Lead Termination	Flying Leads
Motor Standards	NEMA
Motor Type	0524M
Mounting Arrangement	F1
Number of Poles	2
Overall Length	12.88 IN
Power Factor	83
Product Family	Super-E Chemical Processing
Pulley End Bearing Type	Ball
Pulley Face Code	Standard
Pulley Shaft Indicator	Standard
Rodent Screen	None
Service Factor	1.15
Shaft Diameter	0.875 IN
Shaft Extension Location	Pulley End
Shaft Ground Indicator	No Shaft Grounding
Shaft Rotation	Reversible
Shaft Slinger Indicator	Shaft Slinger
Speed	3450 rpm

Speed Code	Single Speed
Starting Method	Direct on line
Thermal Device - Bearing	None
Thermal Device - Winding	None
Vibration Sensor Indicator	No Vibration Sensor
Winding Thermal 1	None
Winding Thermal 2	None

Nameplate

NP3258							
CAT.NO.	ECP3583T						
SPEC.	05F008W116G4						
HP	1.5 TE						
VOLTS	208-230/460						
AMP	4.3-4/2						
RPM	3450						
FRAME	143T	HZ	60	PH	3		
SER.F.	1.15	CODE	M	DES	B	CL	F
RATING	40C AMB-CONT						
SN							
DE	6205	ODE	6205				
NEMA-NOM-EFF	85.5	PF	83				
G.MIN.EFF	82.5	CC	010A				
T. CODE	T4	T=	135				

NP3261			
SPEC.	05F008W116G4		
D.E. BRG.	25BC02XP30X		
O.D.E. BRG.	25BC02XP30X		
GREASE	POLYREX EM		
RPM MAX	5400	MAX. KVAR	0.25
BLANK			
INV.TYPE	PWM		
T=	135		
C HP FR	60	C HP TO	90
CT HZ FROM	6	CT HZ TO	60
VT HZ FROM	3	VT HZ TO	60
HTR-VOLTS		HTR-AMPS	
HTR-WATTS		MAX. SPACE HEATER TEMP.	

AC Induction Motor Performance Data

Record # 47152

Typical performance - not guaranteed values

Winding: 05WGW116-R023		Type: 0524M		Enclosure: TEFC	
Nameplate Data			460 V, 60 Hz: High Voltage Connection		
Rated Output (HP)	1.5	Full Load Torque	2.3 LB-FT		
Volts	208-230/460	Start Configuration	direct on line		
Full Load Amps	4.3-4/2	Breakdown Torque	10.8 LB-FT		
R.P.M.	3450	Pull-up Torque	8.1 LB-FT		
Hz	60	Locked-rotor Torque	10.2 LB-FT		
NEMA Design Code	B	Starting Current	20.1 A		
Service Factor (S.F.)	1.15	No-load Current	0.88 A		
NEMA Nom. Eff.	85.5	Line-line Res. @ 25°C	8.2 Ω		
Rating - Duty	40C AMB-CONT	Temp. Rise @ Rated Load	32°C		
S.F. Amps		Temp. Rise @ S.F. Load	37°C		
		Rotor inertia	0.0664 LB-FT ²		

Load Characteristics 460 V, 60 Hz, 1.5 HP

% of Rated Load	25	50	75	100	125	150	S.F.
Power Factor	49	68	78	83	87	88	84
Efficiency	71.9	81.3	84.3	85.5	85	84	85.2
Speed	3569	3545	3521	3496	3468	3439	3479
Line amperes	1.03	1.29	1.6	2	2.4	2.8	2.25

ABB Motors and Mechanical Inc.

WINDING # 05WGW116

Typical performance - not guaranteed values.

1.5 HP 3 PH 60 HZ 3450 RPM 460 V 0524M

TORQUES (LB-FT): PO=10.8 PU=8.1 LR=10.2 LRA=20.1

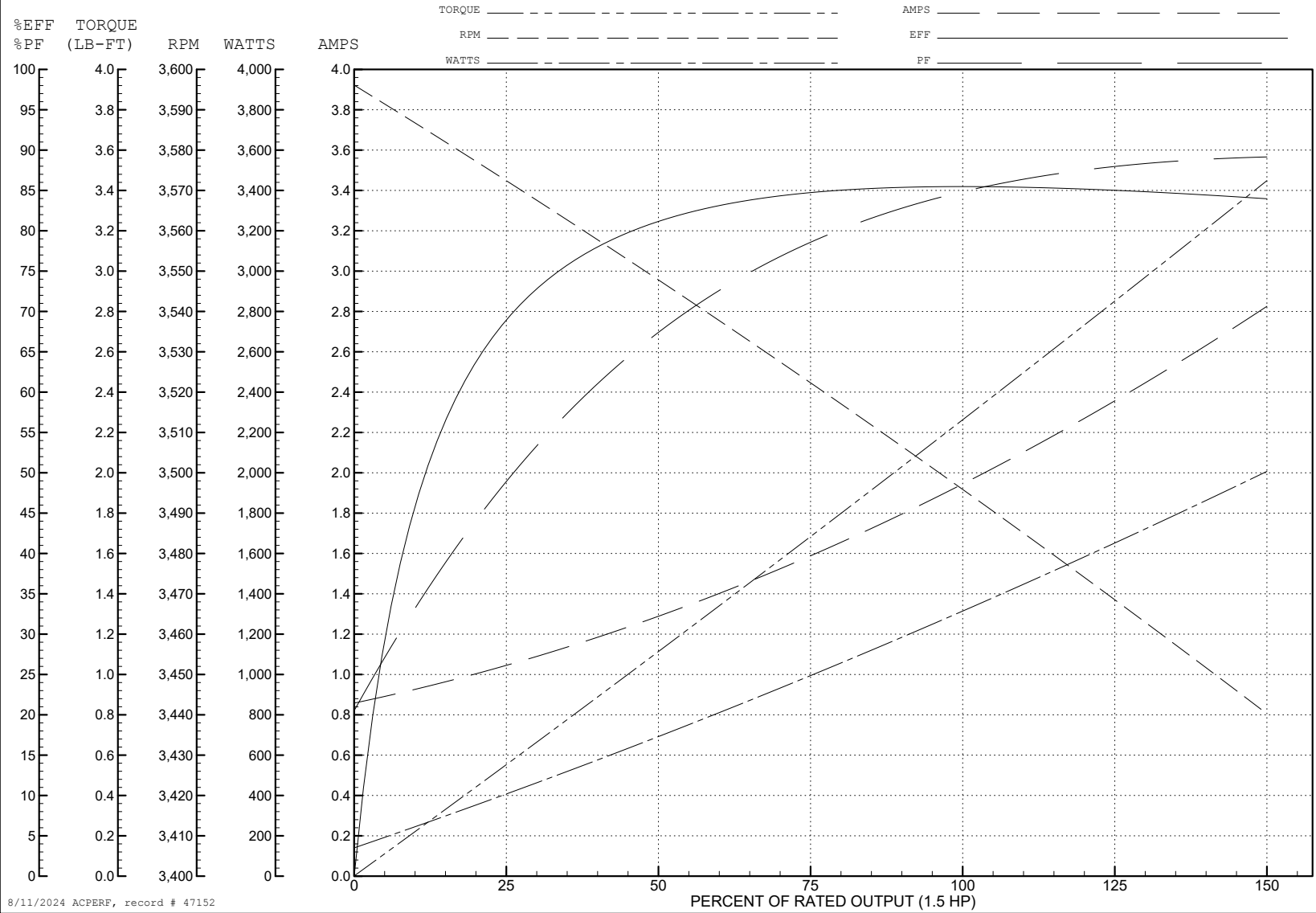

8/11/2024 ACPERF, record # 47152

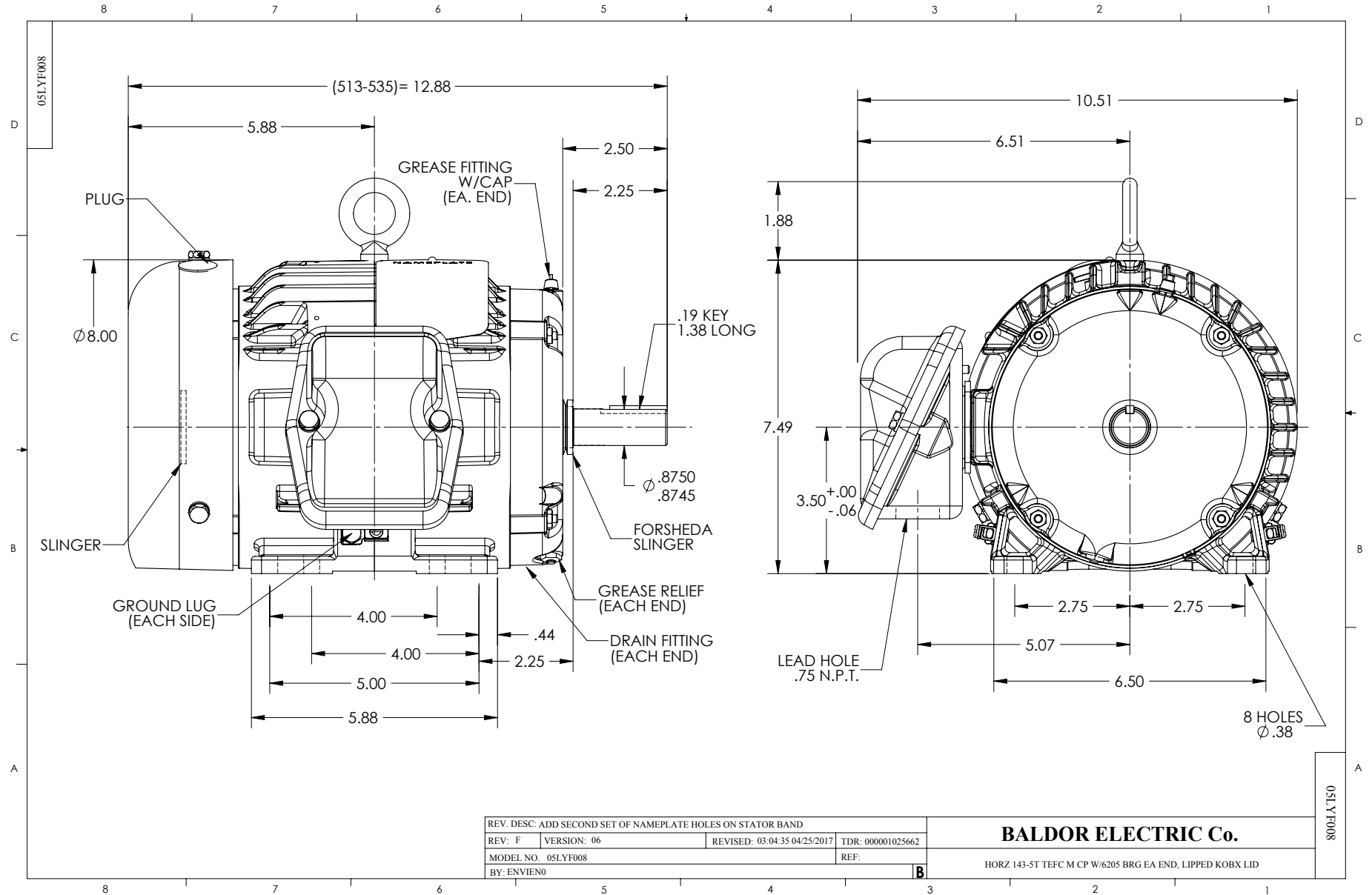

CD0005



LOW VOLTAGE
(2Y)



LINE

HIGH VOLTAGE
(1Y)



LINE

NOTES:

1. INTERCHANGE ANY TWO LINE LEADS TO REVERSE ROTATION.
2. OPTIONAL THERMOSTATS ARE PROVIDED WHEN SPECIFIED.
3. ACTUAL NUMBER OF INTERNAL PARALLEL CIRCUITS MAY BE A MULTIPLE OF THOSE SHOWN ABOVE.
4. LEAD COLORS ARE OPTIONAL. LEADS MUST ALWAYS BE NUMBERED AS SHOWN.

CD0005

REV. DESC: REVISE TO SHOW OPTIONAL COLORS			
REV. LTR: E	BY: JLP	REVISED: 01/19/99 10:15	TDR: 0171435
S00000		FILE: AAA00005140	MDL: -
		MTL: -	

BALDOR ELECTRIC Co.

3PH, DV, 9 LEADS