

ABB BALDOR RELIANCE III

Customer information packet

ECP2332T-4

10HP, 1180RPM, 3PH, 60HZ, 256T, 0960M, TEFC, F1

Class - CLI GP A,B,C,D

Division - Division II

Specifications

Enclosure	TEFC
Frame	256T
Frame Material	Iron
Frequency	60.00 Hz
Haz Area Class and Group	CLI GP A,B,C,D
Haz Area Division	Division II
Motor Letter Type	Three Phase
Output @ Frequency	10.000 HP @ 60 HZ
Phase	3
Synchronous Speed @ Frequency	1200 RPM @ 60 HZ
Voltage @ Frequency	460.0 V @ 60 HZ
Agency Approvals	CSA EEV NEMA PREMIUM NEMA_PREMIUM UR CCSA US
Ambient Temperature	40 °C
Auxiliary Box	NO AUXILLARY BOX
Auxiliary Box Lead Termination	None
Base Indicator	Rigid
Bearing Grease Type	Polyrex EM (-20F +300F)
Blower	None
Constant Torque Speed Range	1.0
Current @ Voltage	14.200 A @ 460.0 V
Design Code	A
Drip Cover	No Drip Cover
Duty Rating	CONT
Efficiency @ 100% Load	91.7 %
Electrically Isolated Bearing	Not Electrically Isolated
Enclosure Modification	Severe Duty Features
Feedback Device	NO FEEDBACK
Front Face Code	Standard

Part Detail

Revision	AZ
Type	AC
Mech. spec.	09J371
Base	
Status	PRD/A
Elec. spec.	09WGY257
Layout	09LYJ371
Eff. date	09-16-2025
CD Diagram	CD0006
Poles	06
Leads	3#12
Proprietary	False
Created date	08-29-2010

Front Shaft Indicator	None
Haz Area Temp Code	T3C
Heater Indicator	No Heater
High Voltage Full Load Amps	14.2 a
Insulation Class	F
Inverter Code	Inverter Duty
KVA Code	J
Lifting Lugs	Standard Lifting Lugs
Locked Bearing Indicator	Locked Bearing
Max Speed	1800 rpm
Motor Lead Exit	Ko Box
Motor Lead Quantity/Wire Size	3 @ 12 AWG
Motor Lead Termination	Flying Leads
Motor Standards	NEMA
Motor Type	0960M
Mounting Arrangement	F1
Number of Poles	6
Overall Length	24.78 IN
Power Factor	72
Product Family	Super-E Chemical Processing
Pulley End Bearing Type	Ball
Pulley Face Code	Standard
Pulley Shaft Indicator	Standard
Rodent Screen	None
Service Factor	1.15
Shaft Diameter	1.625 IN
Shaft Extension Location	Pulley End
Shaft Ground Indicator	No Shaft Grounding
Shaft Rotation	Reversible
Shaft Slinger Indicator	Shaft Slinger
Speed	1180 rpm
Speed Code	Single Speed
Starting Method	Direct on line
Thermal Device - Bearing	None

Thermal Device - Winding	None
Vibration Sensor Indicator	No Vibration Sensor
Winding Thermal 1	None
Winding Thermal 2	None

Nameplate

NP3995ABBL

CAT #	ECP2332T-4		SER		CC	010A					
SPEC	09J371Y257		RATING	40C AMB-CONT							
HZ	VOLTS		AMPS	RPM	HP	CODE	SF	DES	PF	NEMA NOM. EFF	
60	460		14.2	1180	10	J	1.15	A	72 %	91.7 %	
									%	%	
PH	3	CL	F	MAX RPM	1800	MAX CORR KVAR	5.2	USABLE AT 208V	N/A		
IP55		FR	256T	ENCL	TEFC	DE BRG	6309	ODE BRG	6309		
GREASE	POLYREX EM			MTR WT	351	LBS					
USABLE AT	50HZ 7.5HP 380V 13.3A			SF1.0							
CL I DIV 2 GRPS A,B,C,D				CL I ZONE 2 GRPS			IIA,IIB,IIC	TEMP T	160	C	
1.0 SF ON PWM INVERTER			POWER	INV TEMP CL	180	C					
CHP	60-90	HZ	1.5:1	CT	1.0-60	HZ	60:1	VT	0-60	HZ	1000:1
SPACE HEATER LEADS H1-H2:				TIE LIKE NUMBERS			TOGETHER				
V		A		W		MAX SPACE HEATER TEMP					

Accessories

Part number	Description	Multiplier
09-1309	C FACE KIT	A8

ABB Motors and Mechanical Inc.

WINDING # 09WGY257

Typical performance - not guaranteed values.

10 HP 3 PH 60 HZ 1180 RPM 460 V 0960M

TORQUES (LB-FT): PO=144 PU=54.6 LR=75 LRA=93

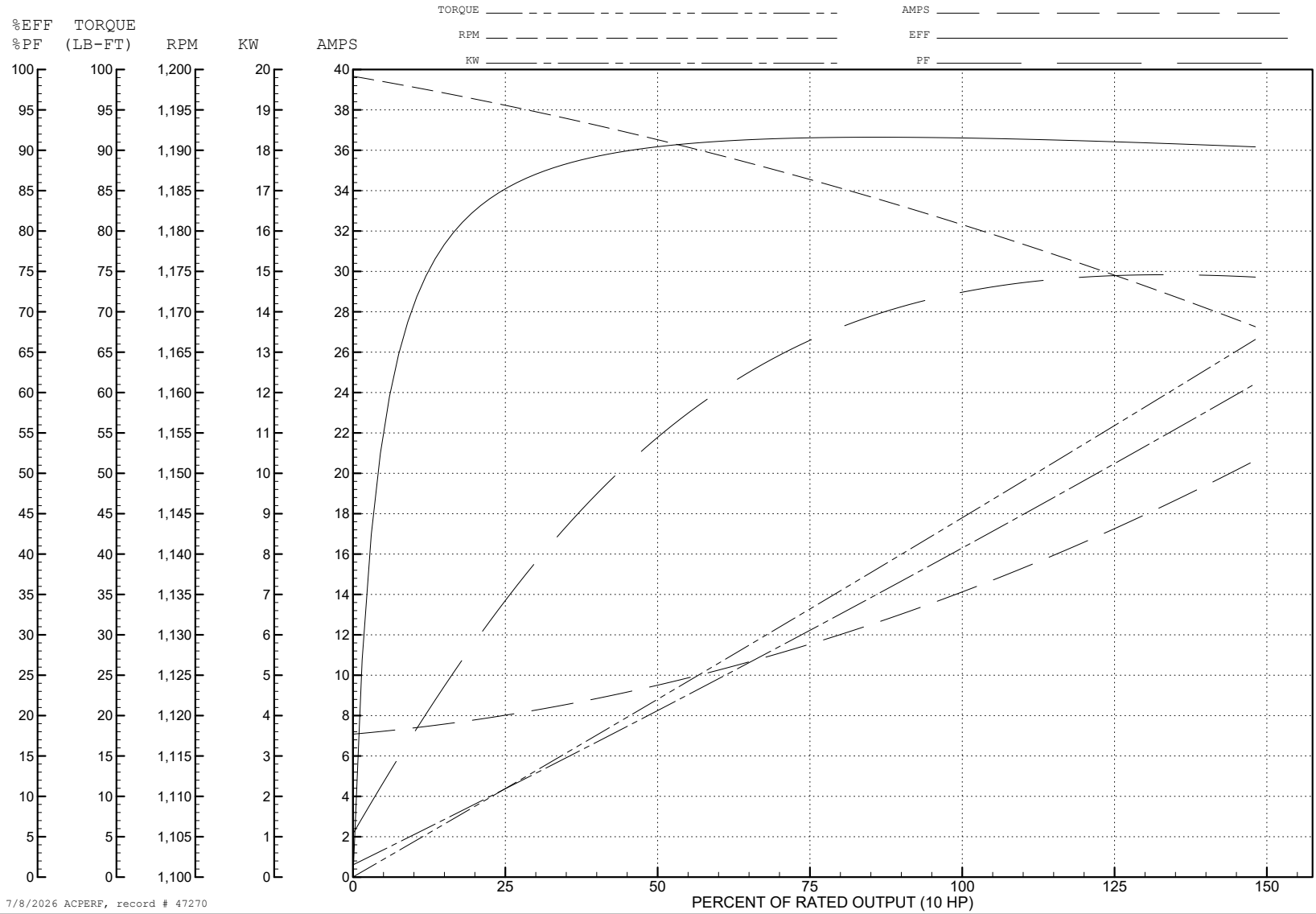

7/8/2026 ACPERF, record # 47270

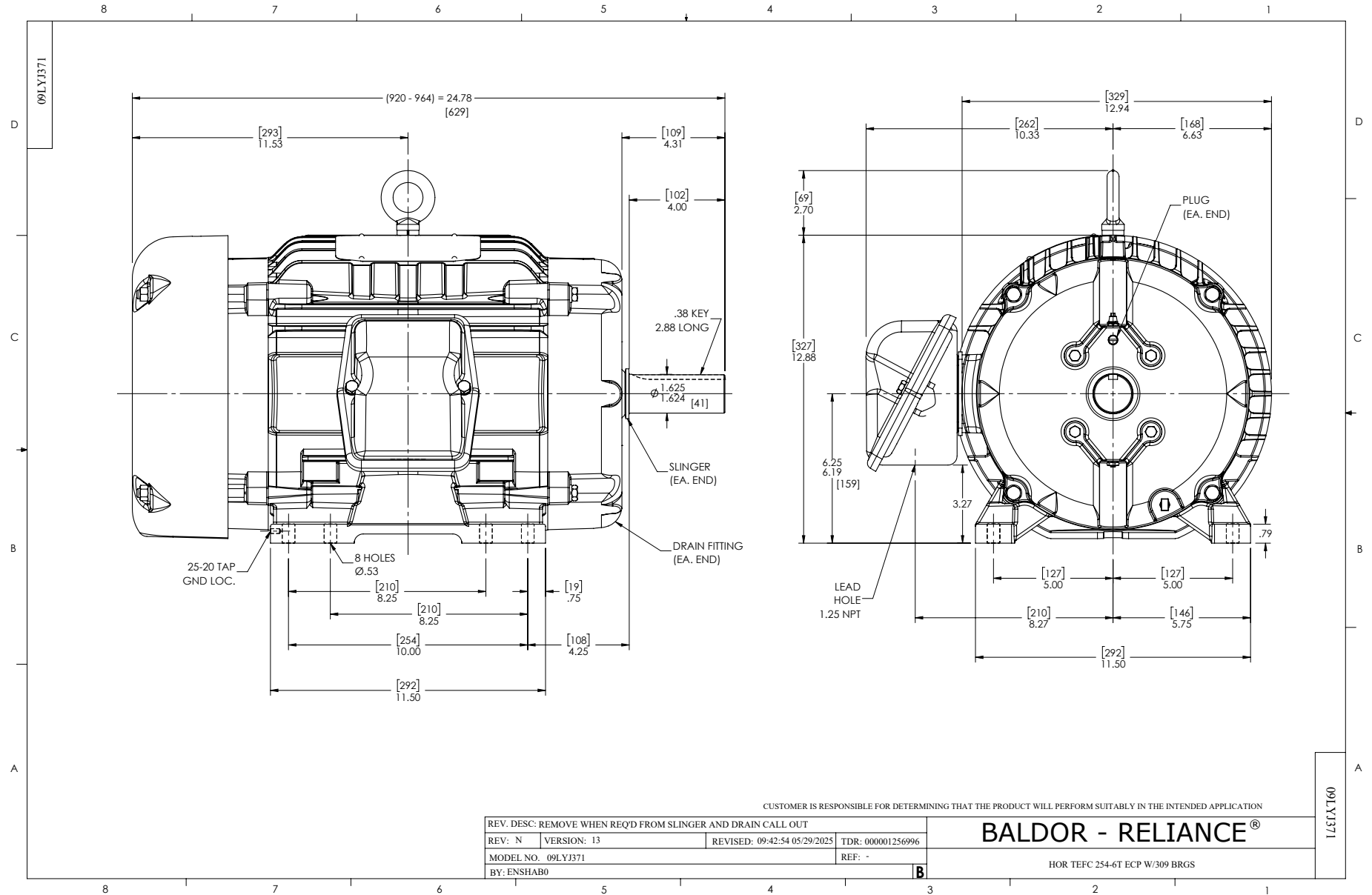

CD0006



NOTES:

1. THREE LEAD MOTOR MAY BE EITHER WYE CONNECTED OR DELTA CONNECTED.
2. INTERCHANGE ANY TWO LINE LEADS TO REVERSE ROTATION.
3. OPTIONAL THERMOSTATS ARE PROVIDED WHEN SPECIFIED.
4. ACTUAL NUMBER OF INTERNAL PARALLEL CIRCUITS MAY VARY.
5. LEAD COLORS ARE OPTIONAL. LEADS MUST BE NUMBERED AS SHOWN.

CD0006

REV. DESC: ADD CLASS CONN00000007		
REV. LTR: E	VERSION: 01	TDR: 000001099922
FILE: \AAA\00005\141	REVISED: 10:24:49 02/19/2019	BY: ENBRIRO
MTL: -	© □	

BALDOR - RELIANCE®

3PH, SV, 3 LEADS, WYE OR DELTA CONNECTED

SH 1 of 1