

# ABB BALDOR RELIANCE III



## Customer information packet

ECP2276T

7.5HP, 1180RPM, 3PH, 60HZ, 254T, 0954M, TEFC, F

Class - CLI GP A,B,C,D

Division - Division II

**Specifications**

<b>Enclosure</b>	TEFC
<b>Frame</b>	254T
<b>Frame Material</b>	Iron
<b>Frequency</b>	60.00 Hz
<b>Haz Area Class and Group</b>	CLI GP A,B,C,D
<b>Haz Area Division</b>	Division II
<b>Motor Letter Type</b>	Three Phase
<b>Output @ Frequency</b>	7.500 HP @ 60 HZ
<b>Phase</b>	3
<b>Synchronous Speed @ Frequency</b>	1200 RPM @ 60 HZ
<b>Voltage @ Frequency</b>	460.0 V @ 60 HZ 230.0 V @ 60 HZ
<b>Agency Approvals</b>	CCSA US CSA EEV NEMA PREMIUM NEMA_PREMIUM UR
<b>Ambient Temperature</b>	40 °C
<b>Auxiliary Box</b>	NO AUXILLARY BOX
<b>Auxiliary Box Lead Termination</b>	None
<b>Base Indicator</b>	Rigid
<b>Bearing Grease Type</b>	Polyrex EM (-20F +300F)
<b>Blower</b>	None
<b>Constant Torque Speed Range</b>	1.0
<b>Current @ Voltage</b>	25.000 A @ 208.0 V 21.400 A @ 230.0 V 10.700 A @ 460.0 V
<b>Design Code</b>	A
<b>Drip Cover</b>	No Drip Cover
<b>Duty Rating</b>	CONT
<b>Efficiency @ 100% Load</b>	91.0 %
<b>Electrically Isolated Bearing</b>	Not Electrically Isolated

**Part Detail**

<b>Revision</b>	AZ
<b>Type</b>	AC
<b>Mech. spec.</b>	09J371
<b>Base</b>	
<b>Status</b>	PRD/A
<b>Elec. spec.</b>	09WGX827
<b>Layout</b>	09LYJ371
<b>Eff. date</b>	09-16-2025
<b>CD Diagram</b>	CD0005
<b>Poles</b>	06
<b>Leads</b>	9#12
<b>Proprietary</b>	False
<b>Created date</b>	08-29-2010

<b>Enclosure Modification</b>	<b>Severe Duty Features</b>
<b>Feedback Device</b>	NO FEEDBACK
<b>Front Face Code</b>	Standard
<b>Front Shaft Indicator</b>	None
<b>Haz Area Temp Code</b>	T3C
<b>Heater Indicator</b>	No Heater
<b>High Voltage Full Load Amps</b>	10.7 a
<b>Insulation Class</b>	F
<b>Inverter Code</b>	Inverter Duty
<b>KVA Code</b>	J
<b>Lifting Lugs</b>	Standard Lifting Lugs
<b>Locked Bearing Indicator</b>	Locked Bearing
<b>Max Speed</b>	1800 rpm
<b>Motor Lead Exit</b>	Ko Box
<b>Motor Lead Quantity/Wire Size</b>	9 @ 12 AWG
<b>Motor Lead Termination</b>	Flying Leads
<b>Motor Standards</b>	NEMA
<b>Motor Type</b>	0954M
<b>Mounting Arrangement</b>	F1
<b>Number of Poles</b>	6
<b>Overall Length</b>	24.78 IN
<b>Power Factor</b>	71
<b>Product Family</b>	Super-E Chemical Processing
<b>Pulley End Bearing Type</b>	Ball
<b>Pulley Face Code</b>	Standard
<b>Pulley Shaft Indicator</b>	Standard
<b>Rodent Screen</b>	None
<b>Service Factor</b>	1.15
<b>Shaft Diameter</b>	1.625 IN
<b>Shaft Extension Location</b>	Pulley End
<b>Shaft Ground Indicator</b>	No Shaft Grounding
<b>Shaft Rotation</b>	Reversible
<b>Shaft Slinger Indicator</b>	Shaft Slinger
<b>Speed</b>	1180 rpm

<b>Speed Code</b>	Single Speed
<b>Starting Method</b>	Direct on line
<b>Thermal Device - Bearing</b>	None
<b>Thermal Device - Winding</b>	None
<b>Vibration Sensor Indicator</b>	No Vibration Sensor
<b>Winding Thermal 1</b>	None
<b>Winding Thermal 2</b>	None

**Nameplate**

**NP3995ABAL**

<b>CAT #</b>	ECP2276T		<b>SER</b>			<b>CC</b>	010A								
<b>SPEC</b>	09J371X827		<b>RATING</b>	40C AMB-CONT											
<b>HZ</b>	<b>VOLTS</b>		<b>AMPS</b>		<b>RPM</b>	<b>HP</b>	<b>CODE</b>	<b>SF</b>	<b>DES</b>	<b>PF</b>	<b>NEMA NOM. EFF</b>				
60	230/460		21.4/10.7		1180	7.5	J	1.15	A	71	%	91	%		
											%		%		
<b>PH</b>	3	<b>CL</b>	F	<b>MAX RPM</b>	1800	<b>MAX CORR KVAR</b>	4.15	<b>USABLE AT 208V</b>		N/A					
<b>IP55</b>		<b>FR</b>	254T	<b>ENCL</b>	TEFC	<b>DE BRG</b>	6309	<b>ODE BRG</b>	6309						
<b>GREASE</b>	POLYREX EM					<b>MTR WT</b>	337	<b>LBS</b>							
<b>USABLE AT</b>	50HZ 5HP 190/380V 18.6/9.3A					SF1.0									
										<b>CL I DIV 2 GRPS A,B,C,D</b>	<b>CL I ZONE 2 GRPS</b>	<b>IIA,IIB,IIC</b>	<b>TEMP T</b>	160	<b>C</b>
										<b>1.0 SF ON PWM INVERTER</b>	<b>POWER</b>	<b>INV TEMP CL</b>	180	<b>C</b>	
<b>CHP</b>	60-90	<b>HZ</b>	1.5:1	<b>CT</b>	1.0-60	<b>HZ</b>	60:1	<b>VT</b>	0-60	<b>HZ</b>	1000:1				
										<b>SPACE HEATER LEADS H1-H2:</b>	<b>TIE LIKE NUMBERS</b>	<b>TOGETHER</b>			
<b>V</b>		<b>A</b>		<b>W</b>		<b>MAX SPACE HEATER TEMP</b>									

ABB Motors and Mechanical Inc.

WINDING # 09WGX827

Typical performance - not guaranteed values.

7.5 HP 3 PH 60 HZ 1180 RPM 460 V 0954M

TORQUES (LB-FT): PO=99.2 PU=39.4 LR=57.8 LRA=69.7

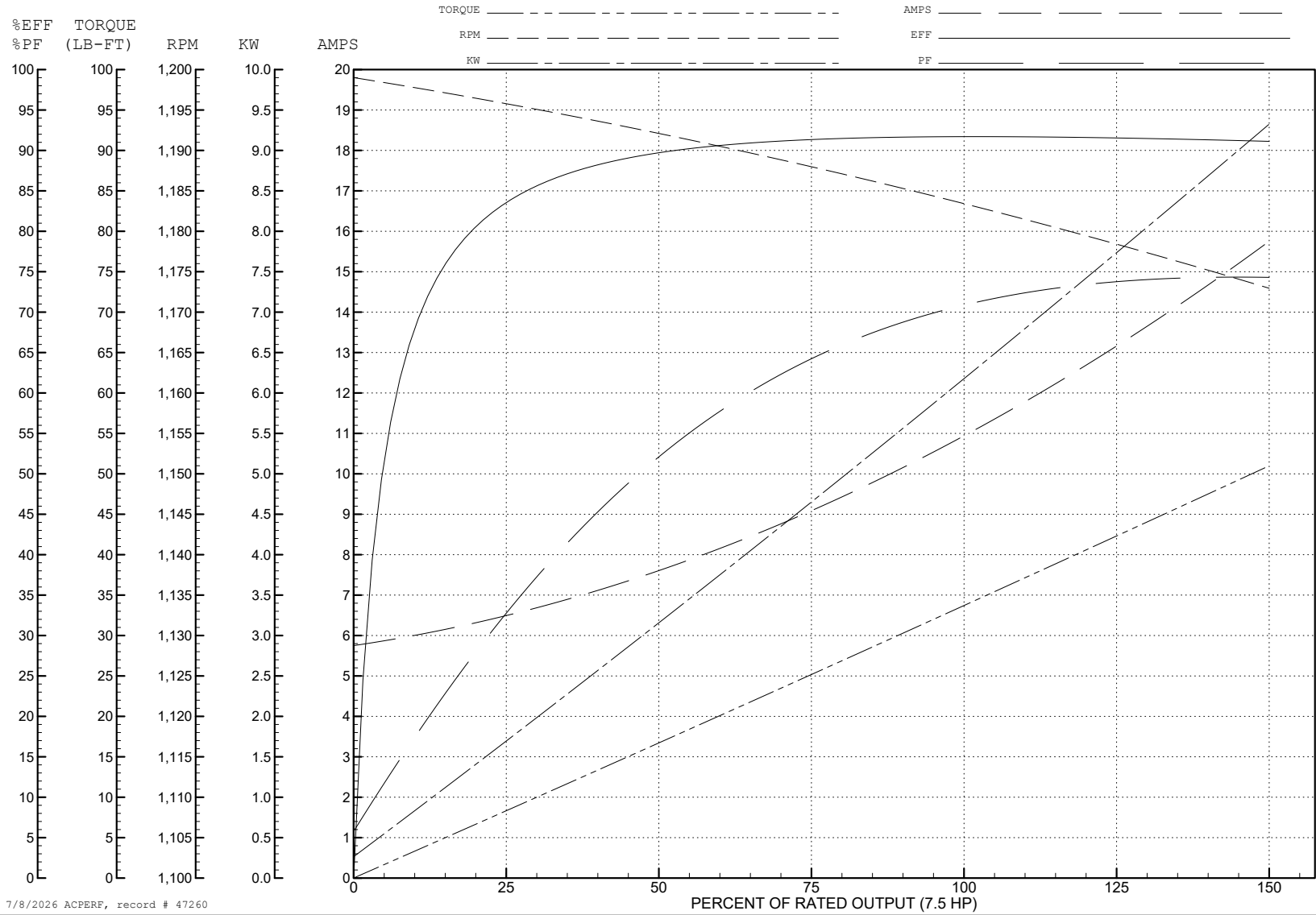

7/8/2026 ACPERF, record # 47260

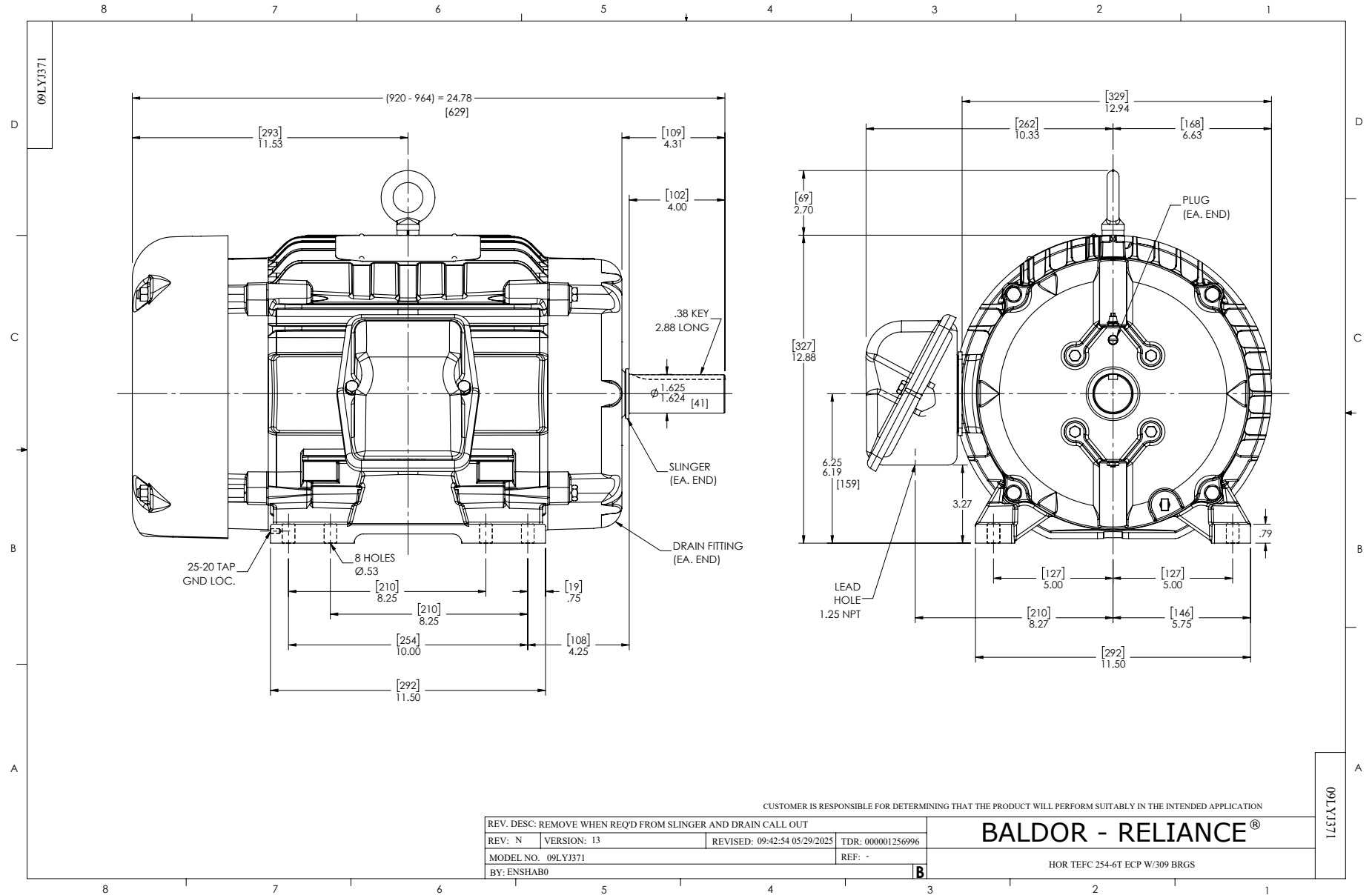

CD0005



LOW VOLTAGE  
(2Y)



HIGH VOLTAGE  
(1Y)

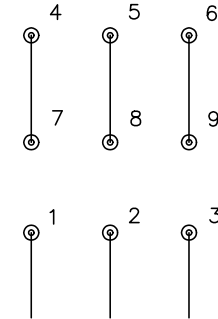

NOTES:

1. INTERCHANGE ANY TWO LINE LEADS TO REVERSE ROTATION.
2. OPTIONAL THERMOSTATS ARE PROVIDED WHEN SPECIFIED.
3. ACTUAL NUMBER OF INTERNAL PARALLEL CIRCUITS MAY BE A MULTIPLE OF THOSE SHOWN ABOVE.
4. LEAD COLORS ARE OPTIONAL. LEADS MUST ALWAYS BE NUMBERED AS SHOWN.

CD0005

REV. DESC: REVISE TO SHOW OPTIONAL COLORS

REV. LTR: E BY: JLP REVISED: 01/19/99 10:15 TDR: 0171435

500000

FILE: AAA00005140

MDL: -

MTL: -

**BALDOR ELECTRIC Co.**

3PH, DV, 9 LEADS