

ABB BALDOR RELIANCE III

Customer information packet D2040P-BV

0328AT, 40HP, 1750RPM, 240, 300, DPBV, F1

Specifications

Armature Voltage	240 V
Base Speed	1750 rpm
Enclosure	DPFG
Field Voltage	300 V
Frame	328AT
Output Power	40.000 HP
Agency Approvals	CSA
Ambient Temperature	40 °C
Armature Current	138.0 a
Drip Cover	No Drip Cover
Duty Rating	CONT
Feedback Device	NO FEEDBACK
Field Winding Type	STR. SHUNT
Heater Indicator	No Heater
Insulation Class	F
Lifting Lugs	Standard Lifting Lugs
Motor Standards	NEMA
Mounting Arrangement	F1
Overall Length	34.63 IN
Service Factor	1.00
Shaft Diameter	2.125 IN
Shaft Ground Indicator	No Shaft Grounding
Shaft Slinger Indicator	No Slinger
Thermal Device - Bearing	None

Part Detail

Revision	A
Type	DC
Mech. spec.	
Base	
Status	PRD/A
Elec. spec.	K0080A B
Layout	1336-4
Eff. date	10-03-2023
CD Diagram	15209
Poles	00
Leads	
Proprietary	False
Created date	12-18-2019

Nameplate

NP1734					
CAT.NO.	D2040P-BV	MODEL	T32S8003		
HP	40	RPM	1750/2100	FRAME	0328AT
ARM V	240	ARM A	138.00	WOUND	STR. SHUNT
FLD V	150/300	FLD A	2.64-2.00/1.32-1.00		
CONN		OHMS	145.6	CL	F
ENCL	DPBV	DUTY	CONT	MX AMB	40
P CODE	D	CTSR		SER.F.	1.0
S/N		E/S	K0080A B		
	-				
O.D.E. BRG.	6210	D.E. BRG.	6211	BRUSH	28610-1
				QTY	4

Accessories

Part number	Description	Multiplier
94EP5000A02	C-FACE CONVERSION KIT FOR STOCK MTR,FR 3	

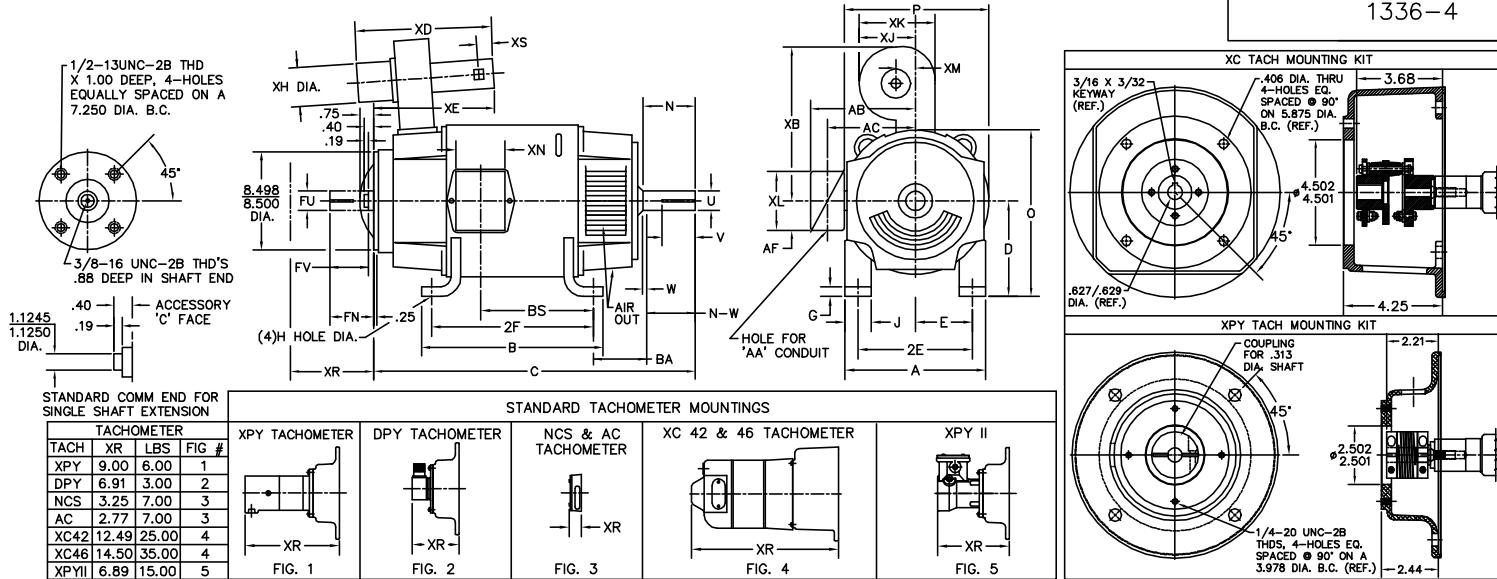

STANDARD COMM END FOR SINGLE SHAFT EXTENSION

TACH	XR	LBS	FIG #
XPY	9.00	6.00	1
DPY	6.91	3.00	2
NCS	3.25	7.00	3
AC	2.77	7.00	3
XC42	12.49	25.00	4
XC46	14.50	35.00	4
XPYII	6.89	15.00	5

STANDARD TACHOMETER MOUNTINGS

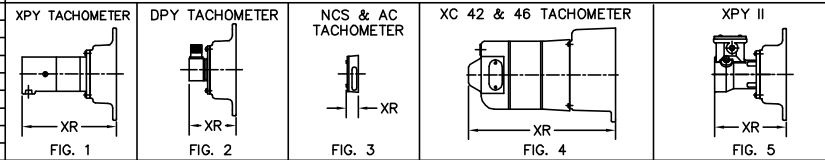

FRAME	FOOT MOUNTING					D.E. SHAFT EXTENSION					DRIVE KEY				ACC SHAFT EXTENSION				FRAME					
	BA	E	2F	G	H	J	N	N-W	U	V	W	KEY-SQ.	KEY-LONG	FN	FU	FV	KEY-SQ.	KEY-LONG	A	B	C	D	O	P
327AT	5.25	6.25	14.00	.81	.656	3.00	4.40	4.25	2.125	4.00 ³	.15	.500	3.12	3.94	1.875	3.69	.500	2.81	15.88	15.75	32.75	8.00 ²	15.94	15.88
328AT	5.25	6.25	16.00	.81	.656	3.00	4.40	4.25	2.125	4.00 ³	.15	.500	3.12	3.94	1.875	3.69	.500	2.81	15.88	17.75	34.63	8.00 ²	15.94	15.88
329AT	5.25	6.25	18.00	.81	.656	3.00	4.40	4.25	2.125	4.00 ³	.15	.500	3.12	3.94	1.875	3.69	.500	2.81	15.88	19.75	36.63	8.00 ²	15.94	15.88
365AT	5.88	7.00	12.25	.81	.813	3.25	4.94	4.75	2.375	4.50 ³	.19	.625	3.50	4.62	2.125	4.37	.500	3.13	17.75	13.75	32.94	9.00 ²	17.94	17.88
366AT	5.88	7.00	14.00	.81	.813	3.25	4.94	4.75	2.375	4.50 ³	.19	.625	3.50	4.62	2.125	4.37	.500	3.13	17.75	15.50	35.13	9.00 ²	17.94	17.88
368AT	5.88	7.00	18.00	.81	.813	3.25	4.94	4.75	2.375	4.50 ³	.19	.625	3.50	4.62	2.125	4.37	.500	3.13	17.75	19.50	38.13	9.00 ²	17.94	17.88
3610AT	5.88	7.00	22.00	.81	.813	3.25	4.94	4.75	2.375	4.50 ³	.19	.625	3.50	4.62	2.125	4.37	.500	3.13	17.75	23.50	41.45	9.00 ²	17.94	17.88
3612AT	5.88	7.00	28.00	.81	.813	3.25	4.94	4.75	2.375	4.50 ³	.19	.625	3.50	4.62	2.125	4.37	.500	3.13	17.75	29.50	45.56	9.00 ²	17.94	17.88

FRAME	CONDUIT BOX					BLOWER										ARM APPROX. WK ² LBS.FT. ²	APPROXIMATE WEIGHT	
	AA	AB	AC	AF	BS	XL	XN	SIZE	XB	XD	XE	XH	XM	XJ	XK			XS
327AT	2	12.94	10.32	5.00	11.81	7.88	5.25	LM6	19.13	26.38	17.38	10.25	4.19	9.44	11.50	3.75	8.45	738 ⁵
328AT	2	12.94	10.32	5.00	13.68	7.88	5.25	LM6	19.13	26.38	17.38	10.25	4.19	9.44	11.50	3.75	9.67	813 ⁵
329AT	2	12.94	10.32	5.00	15.68	7.88	5.25	LM6	19.13	26.38	17.38	10.25	4.19	9.44	11.50	3.75	10.97	922 ⁵
365AT	2 1/2	14.06	11.38	5.00	9.06	7.88	5.25	LM6	18.88	26.38	18.44	10.25	5.69	10.95	11.50	3.75	15.61	803 ⁵
366AT	2 1/2	14.06	11.38	5.00	11.25	7.88	5.25	LM6	18.88	26.38	18.44	10.25	5.69	10.95	11.50	3.75	18.27	913 ⁵
368AT	2 1/2	14.06	11.38	5.00	14.25	7.88	5.25	LM6	18.88	26.38	18.44	10.25	5.69	10.95	11.50	3.75	22.21	1073 ⁵
3610AT	3	16.86	13.09	6.53	18.25	11.63	7.76	LM9	25.50	28.31	20.94	10.75	5.50	12.38	15.25	3.75	28.00	1109 ⁵
3612AT	3	16.86	13.09	6.53	24.25	11.63	7.76	LM9	25.50	28.31	20.94	10.75	5.50	12.38	15.25	3.75	31.60	1145 ⁵

- 1) SHAFT DIAMETERS TO 1.500 TOLERANCE +.0000 - .0005
SHAFT DIAMETERS ABOVE 1.500 TOLERANCE +.0000 - .0010
SHAFT DIAMETERS TO 1.625 RUNOUT .002 T.I.R. MAX.
SHAFT DIAMETERS ABOVE 1.625 RUNOUT .003 T.I.R. MAX.
- 2) 'D' DIMENSION TOLERANCE +.000 - .060
- 3) 'V' DIMENSION IS MAX. HUB LENGTH ON SHAFT
- 4) CONDUIT BOX CAN BE ROTATED IN 90° STEPS ON ITS OWN AXIS.
- 5) TOTAL WEIGHT OF MOTOR AND BLOWER LESS TACH WEIGHT
- 6) ALL DIMENSIONS NOT NOTED ARE NOMINAL DIMENSIONS CONSULT FACTORY FOR TOLERANCES.

FOR F1 OR F2 CONDUIT BOX LOCATION SEE SALES ORDER

CUSTOMER IS RESPONSIBLE FOR DETERMINING THAT BALDOR'S PRODUCT WILL PERFORM SUITABLY IN THE INTENDED APPLICATION.

REV. DESC: REV. "D" DIM TO +.000 -.060 ONLY	VERSION: 01	TDR: 000000752448
REV. LTR: G	FILE: \RGG\00019\490	REVISED: 01:55:17 06/19/2012
MTL: -		BY: RGGNAS



DIM SHEET: 327-3612AT,DPBV,W/TACH
SH 1 of 1

1336-4

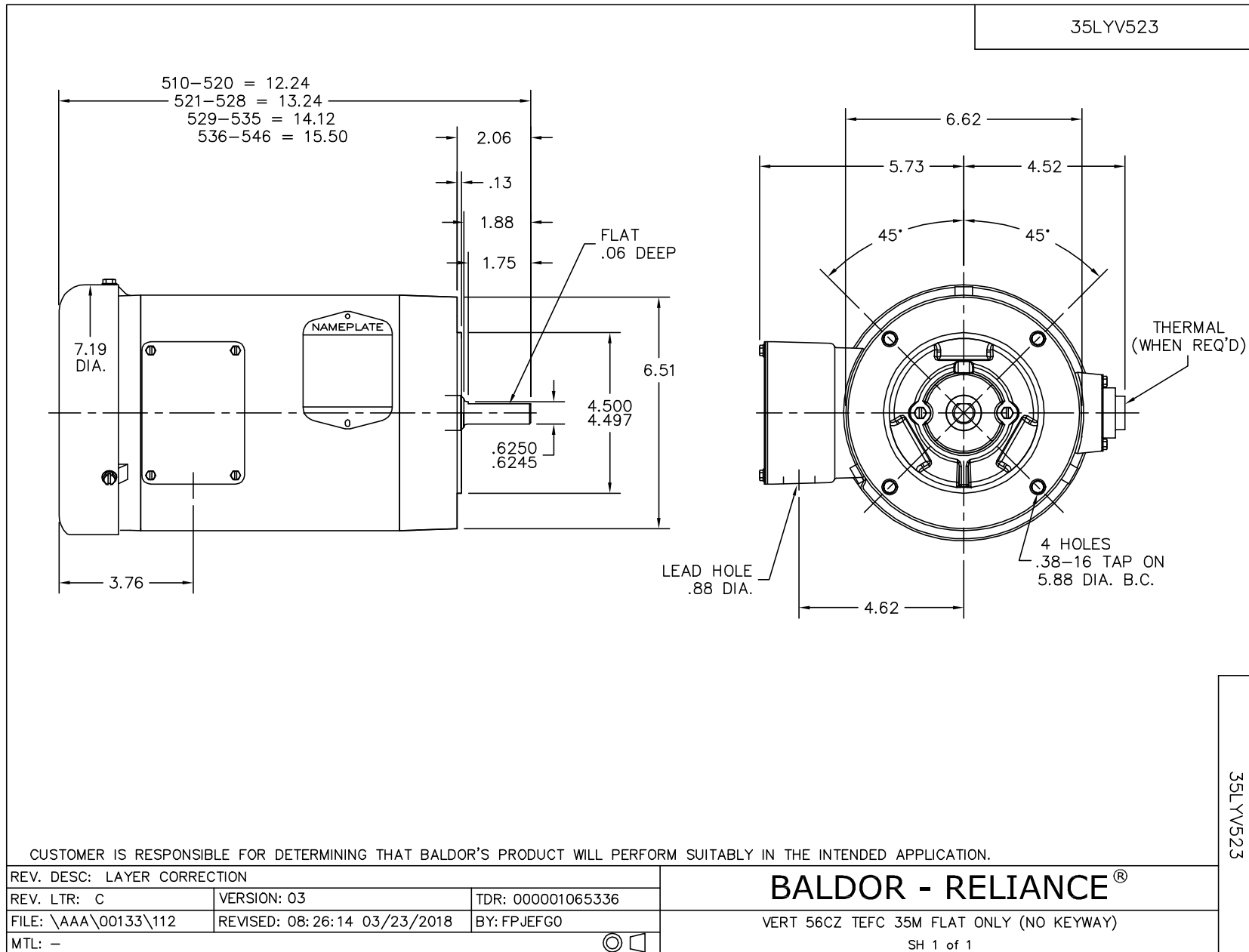

15209

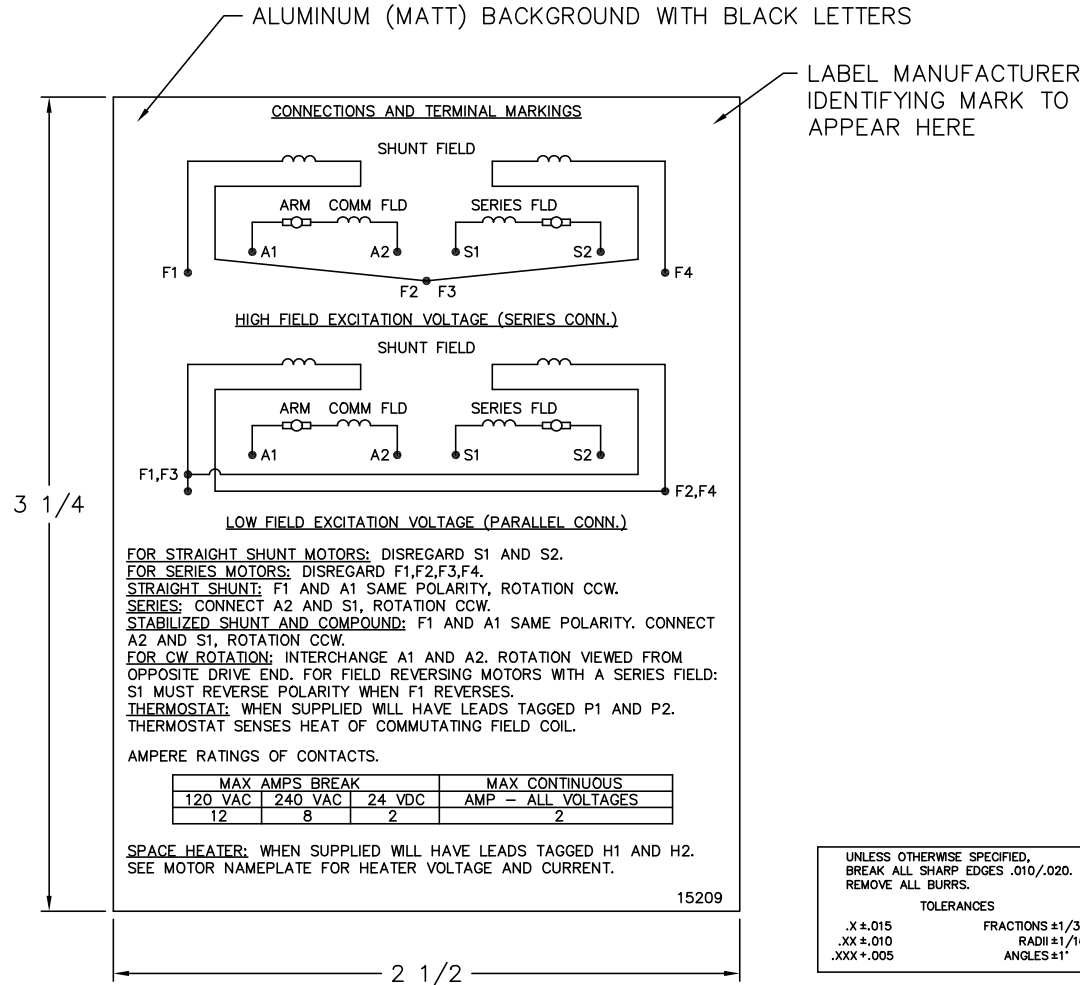

NOTE:
 MATERIAL .005 MINIMUM FULL HARD ALUMINUM DULL FINISH.
 TEMP. RANGE -20°C TO +125°C MAXIMUM.
 FOR INDOOR AND OUTDOOR MOUNTING BACK.
 METAL, PRESSURE SENSITIVE BACK. MUST MEET CSA STANDARD.
 THE CSA IDENTIFYING MARK OF THE LABEL MANUFACTURER MUST APPEAR IN THE UPPER RIGHT HAND CORNER AS INDICATED.

UNLESS OTHERWISE SPECIFIED, BREAK ALL SHARP EDGES .010/.020. REMOVE ALL BURRS.

TOLERANCES

.X ±.015 FRACTIONS ±1/32
 .XX ±.010 RADII ±1/16
 .XXX ±.005 ANGLES ±1°

15209

MATL: NOTED			
REV:	G	CHANGE ALL "NAMEPLATE" TEXT TO "LABEL"	
60Z91		SCALE: -	BY: BKW
		FILE: CHB00002485	REVISED: 02/19/97
		TDR: 0115147	

BALDOR ELECTRIC Co.

LABEL, CONNECTIONS AND TERMINAL MARKINGS DC