

DUTY MASTER ALTERNATING CURRENT MOTORS

ENCLOSURE: TOTALLY ENCLOSED
 SQUIREL-CAGE INDUCTION
 CAST IRON CONSTRUCTION
 COOLING: FAN COOLED
 MOUNTING: FOOT

FRAMES 250T THRU 440T

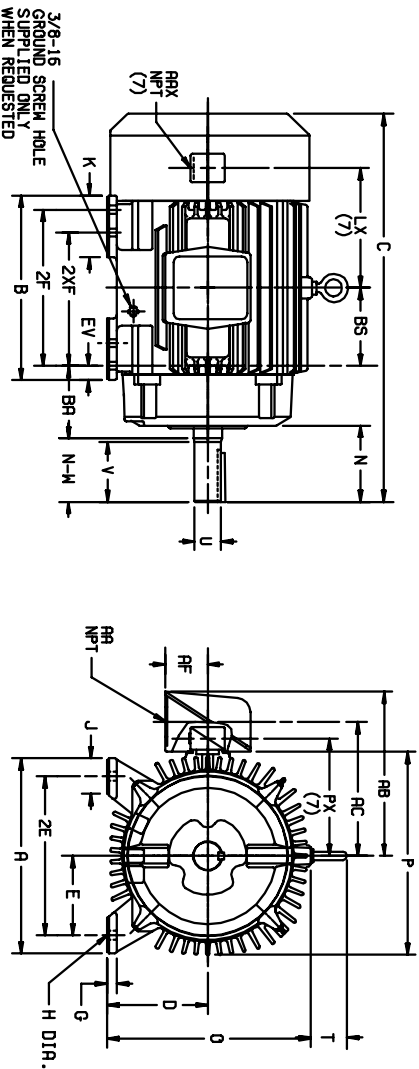

DIMENSIONS ARE IN INCHES; SEE SHEET 2 FOR DIMENSIONS IN MILLIMETERS

FRAME	A	D(2)	E	G	H	J	K	O	P	T	CAST IRON TERMINAL BOX (7) AUX. CONDUIT BOX						BA	EV	
											AA	AB	AC	AF	AAX	LX (7)	PX (7)		
254T-256T	12.50	6.25	5.00	.75	.56	2.50	---	13.25	13.25	2.44	1-1/4	10.81	8.81	2.50	3/4	6.31	9.31	4.25	1.00
284T-286TS	13.75	7.00	5.50	.75	.56	2.50	---	14.75	14.88	2.44	1-1/2	12.62	10.19	3.00	3/4	6.88	10.50	4.75	1.00
324T-326TS	15.50	8.00	6.25	.88	.69	2.75	4.50	16.69	17.00	2.44	2	15.44	11.69	3.62	3/4	8.00	10.50	5.25	1.38
364T-365TS	17.00	9.00	7.00	.88	.69	2.75	3.88	18.50	19.50	2.94	3	18.00	13.81	4.12	3/4	8.38	11.62	5.88	1.38
404T-405TS	19.00	10.00	8.00	1.12	.81	3.25	4.62	21.31	22.50	2.94	3	19.25	15.06	4.12	3/4	9.62	14.44	6.62	1.13
444T-445TS	21.00	11.00	9.00	1.12	.81	3.25	5.25	23.38	25.25	3.25	3	22.19	17.44	6.00	3/4	11.12	15.25	7.50	1.25

FRAME	A	C	BS	B	2F	2XF	(4)	N	N	N-W(6)	U(3)	V	SQ.	LGTH.	WEIGHT
SIZE															(5)
254T	24.56	5.00	12.00	---	8.25	4.12	4.12	4.00	1.625	3.75	.375	.375	2.88	3.35	
256T	24.56	5.00	12.00	10.00	---	4.12	4.00	1.625	3.75	.375	.375	2.88	3.45		
284T	27.44	5.50	13.00	---	9.50	5.00	4.82	1.875	4.38	.500	.500	3.25	4.75		
284TS	26.06	5.50	13.00	---	9.50	3.62	3.25	1.625	3.00	.375	1.88	4.75			
286T	27.44	5.50	13.00	11.00	---	5.00	4.62	1.875	4.38	.500	3.25	4.90			
286TS	26.06	5.50	13.00	11.00	---	5.00	3.62	1.625	3.00	.375	1.88	4.90			
324T	30.44	6.00	14.75	---	10.50	5.62	5.25	2.125	5.00	.500	3.88	5.90			
324TS	28.94	6.00	14.75	---	10.50	4.12	3.75	1.875	3.50	.500	2.00	5.90			
326T	30.44	6.00	14.75	12.00	---	5.62	5.25	2.125	5.00	.500	3.88	6.30			
326TS	28.94	6.00	14.75	12.00	---	4.12	3.75	1.875	3.50	.500	2.00	6.30			
364T	33.44	6.12	15.00	---	11.25	6.25	5.88	2.375	5.62	.625	4.25	8.65			
364TS	31.31	6.12	15.00	---	11.25	4.12	3.75	1.875	3.50	.500	2.00	8.59			
365T	33.44	6.12	15.00	12.25	---	6.25	5.88	2.375	5.62	.625	4.25	8.90			
365TS	31.31	6.12	15.00	12.25	---	4.12	3.75	1.875	3.50	.500	2.00	8.84			
404T	38.31	6.88	16.00	---	12.25	7.50	7.25	2.875	7.00	.750	5.62	12.20			
404TS	35.31	6.88	16.00	---	12.25	4.50	4.25	2.125	4.00	.500	2.75	12.11			
405T	38.31	6.88	16.00	13.75	---	7.50	7.25	2.875	7.00	.750	5.62	12.60			
405TS	35.31	6.88	16.00	13.75	---	4.50	4.25	2.125	4.00	.500	2.75	12.51			
444T	44.82	8.25	19.00	---	14.50	8.94	8.50	3.375	8.25	.875	6.88	16.70			
444TS	40.88	8.25	19.00	---	14.50	5.19	4.75	2.375	4.50	.625	3.00	16.54			
445T	44.82	8.25	19.00	16.50	---	8.94	8.50	3.375	8.25	.875	6.88	16.60			
445TS	40.88	8.25	19.00	16.50	---	5.19	4.75	2.375	4.50	.625	3.00	16.44			

- (1) SPECIAL DIMENSIONS APPLYING TO THIS ORDER ON THIS LINE.
- (2) "D" VARIES $\left[\begin{array}{l} 250T - 320T +.00, -.03 \\ 360T - 440T +.00, -.06 \end{array} \right.$
- (3) "U" VARIES $\left[\begin{array}{l} \text{HP TO 1.625 DIA.} +.0000, -.0005 \\ 1.625 \text{ AND LARGER} +.000, -.001 \end{array} \right.$
- (4) ALL FRAMES HAVE EIGHT MOUNTING HOLES FOR DUAL MOUNTING.
- (5) MOTOR WEIGHTS MAY VARY BY 15% DEPENDING UPON RATING.
- (6) "N-W" VARIES +.00, -.25.
- (7) AUXILIARY CONDUIT BOX SUPPLIED WHEN SPECIFIED

CONDUIT BOXES LOCATED ON OPPOSITE SIDE WHEN F-2,W-1, W-4,W-5,W-7, OR C-1 MOUNTING IS SPECIFIED.
 IF MOUNTING CLEARANCE DETAILS ARE REQUIRED, CONSULT FACTORY.
 MAXIMUM PERMISSIBLE SHAFT RUNOUT WHEN MEASURED AT END OF STD. SHAFT EXTENSION IS .002 T.I.R. UP TO AND INCLUDING 1.625 DIA. AND .003 T.I.R. 1.625 DIA. TO 5 INCH DIA.

FRAME _____ TYPE _____ CERTIFIED FOR _____
 ORDER _____ ITEM _____ HP _____ RPM _____ PH _____ HZ _____ VOLTS _____
 SALES ORDER _____ APPROVED BY _____ DATE _____

LHS-105-047119

CUSTOMER IS RESPONSIBLE FOR DETERMINING THAT MOTOR PERFORMANCE IS SUITABLE IN THE APPLICATION.

REV. DESC: REMOVING TITLEBLOCK	VERSION: 01	TDR: 00000448517
REV. LTR: A	REVISED: 14:06:59 11/07/2007	BY: CONBPM
FILE: \RAG\00004\525		
MTL: -		



DIM SHT 250T-440T TEFC FT MTG STD T & TS SGL EXT XT