

FRONT END DETAIL

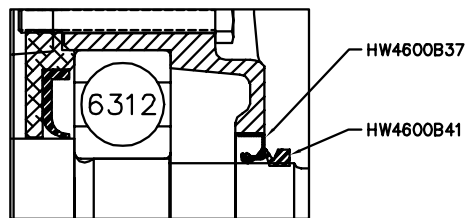

PULLEY END DETAIL

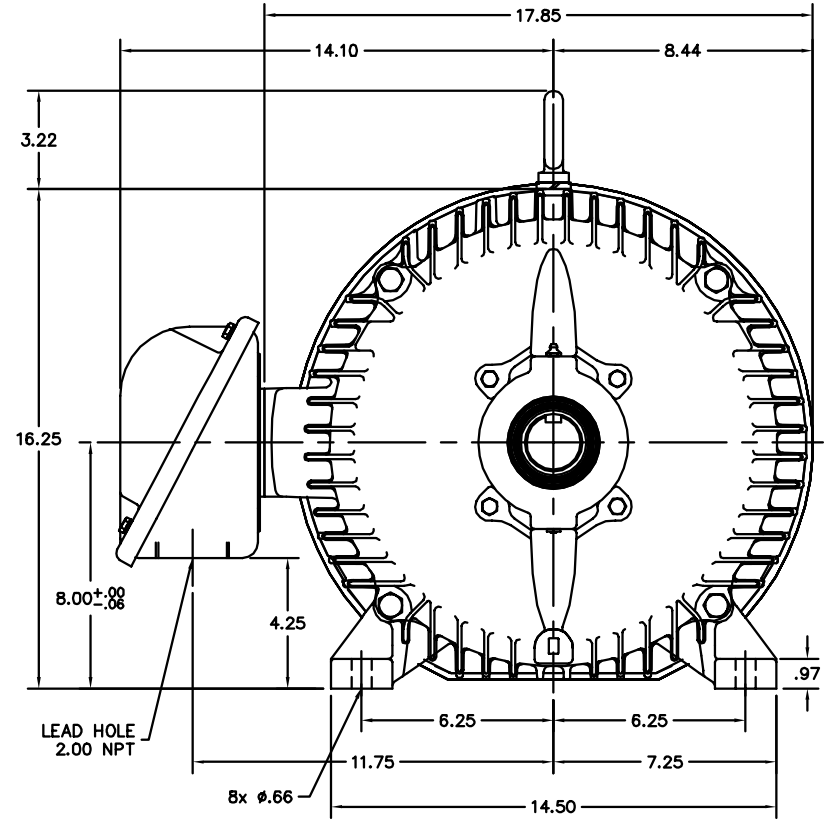

CUSTOMER IS RESPONSIBLE FOR DETERMINING THAT BALDOR'S PRODUCT WILL PERFORM SUITABLY IN THE INTENDED APPLICATION.

REV. DESC: HW4600A91 WAS HW4600A90	VERSION: 04	TDR: 000001137087
REV. LTR: D	REVISD: 07:39:11 04/03/2020	BY: ENSHABO
FILE: \AAA\00167\088	MTL: -	

BALDOR - RELIANCE®

HOR TEFC 324-6T ECP 312 DBL SHIELD BRGS, SEALS, COOLING TOWER

SH 1 of 1